

# Exhibition stands

in different sizes



9m<sup>2</sup>  
12m<sup>2</sup>  
18m<sup>2</sup>



# Table of contents

7	FREE-STANDING BACKWALLS
8	9M <sup>2</sup> EXHIBITION STAND
18	12M <sup>2</sup> EXHIBITION STAND
29	18M <sup>2</sup> EXHIBITION STAND
42	LIGHT BOX
44	COUNTERS
48	BENEFITS OF FABRIC GRAPHICS AND DYE-SUBLIMATION
49	WHAT IS SEG?
50	YOUR ARTWORK

# Free-standing backwall

Freestanding backwall



- + Housed in an anodized Aluminium frame, your graphic remains perfectly taut to convey your message as clearly as possible
- + Single- or double-sided self-standing backwall
- + Several different type of stabilizing feet available

# Free-standing backwall

Freestanding backwall



## Options

- + Many different fabrics available for a variety of needs
- + £40 / foot
- + Bracket for hanging on wall: £7,50 / bracket
- + Spotlights: 200W Halogen £65 or LED £124

## Graphic specs

Customization possible in heights up to 3 m without junction.



Structure + graphic (front side)  
height

	1000	1500	2000	2500	
width	800	£180	£266	£313	£361
	1000	£202	£294	£348	£401
	2000	£348	£472	£557	£642
	3000	£548	£748	£881	£1014
	4000	£694	£926	£1090	£1255
	5000	£801	£1065	£1261	£1457

- 1 bag on wheels (incl. 1 inner case): £196
- 1 bag on wheels (incl. 2 inner cases): £233



Structure + Graphic (front side and reverse side)  
height

	1000	1500	2000	2500	
width	800	£232	£343	£416	£489
	1000	£266	£390	£476	£561
	2000	£476	£664	£812	£962
	3000	£740	£1035	£1264	£1492
	4000	£950	£1309	£1600	£1892
	5000	£1121	£1543	£1898	£2253

- 1 bag on wheels (incl. 1 inner case): £196
- 1 bag on wheels (incl. 2 inner cases): £233

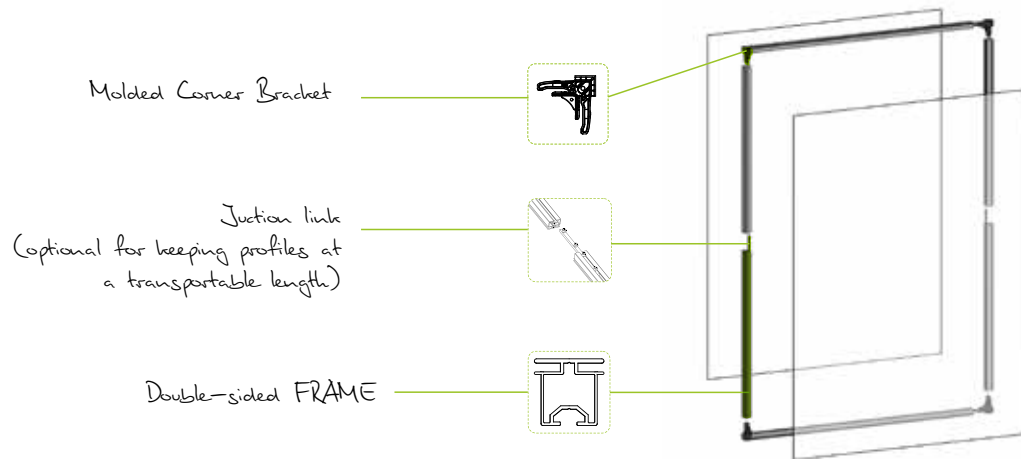

# Small space, big impact — 9 and 12 m<sup>2</sup>

9m<sup>2</sup> and 12m<sup>2</sup> exhibition stands

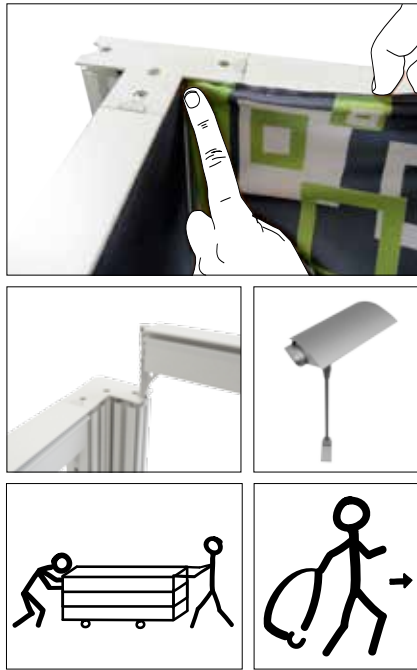

- + Convey a true image of quality with Panoramic, a modular exhibition system that lets you completely cover your structure with fabric graphics
- + All-in-one kit : structure, graphics, lights, tools, packaging
- + Available features (options for some kits): storage areas, shelves, brochure holders, backlighting, monitor mounts

# Free-standing backwall — 9 m<sup>2</sup>

9 m<sup>2</sup> exhibition stand



panoramic™

Structure + Graphic + 2 lights (200 W) + Transport solution

purchase £1 633

rental £1 029

\*excluding furniture.....

Product name  
**PAN-STAND-1**

Transport solution

1 bag on wheels



Arch foot



(200 W) lights

← 3 m →



Standard height 2.5 m

# U-shaped stand with storage

9 m<sup>2</sup> exhibition stand



Storage area



Counter with shelf (counter shelf color: please contact us for more information)\*



Structure + Graphic + 3 x (200 W) lights + Transport solution

purchase **£3 250**

rental **£2 010**

\*excluding furniture.....

Product name  
**PAN-STAND-10**

Transport solution

1 bag on wheels

Options\*

	purchase	rental
counter		
<b>PAN-COUNT-5</b>	<b>£833</b>	<b>£384</b>

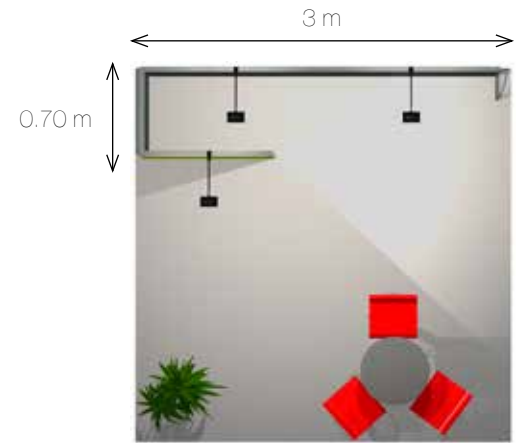

Standard height 2.5 m

# L-shaped stand

9 m<sup>2</sup> exhibition stand



Structure + Graphic + 4 x (200 W) lights + Transport solution

purchase **£3 203**

rental **£2 017**

\*excluding furniture and TV screen

Product name  
**PAN-STAND-2**

Transport solution

2 bags on wheels



Monitor support (Screen 102 cm max, not included)



4 x (200 W) lights

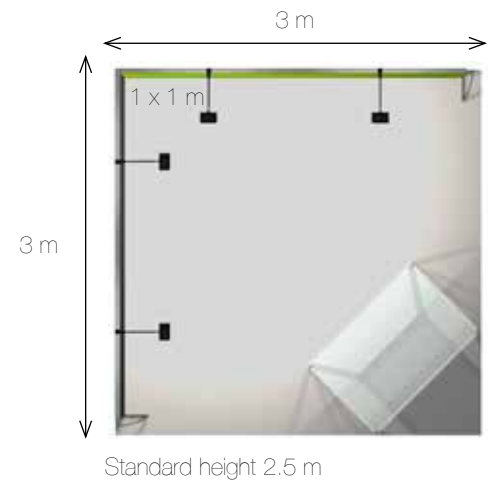

# Backwall with front sign & storage

9 m<sup>2</sup> exhibition stand



panoramic™

Structure + Graphic + 2 x (200 W) lights + Transport solution

purchase £3 612

rental £2 025

\*excluding furniture.....

Product name  
**PAN-STAND-15**

Transport solution

2 bags on wheels

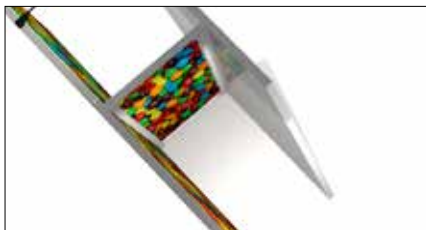

Storage area



Sleek frame & billboard-style panel

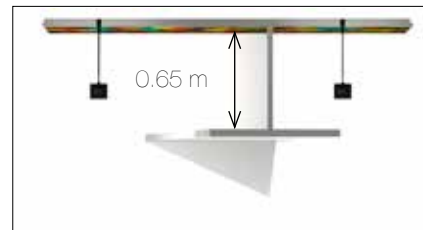

Small footprint

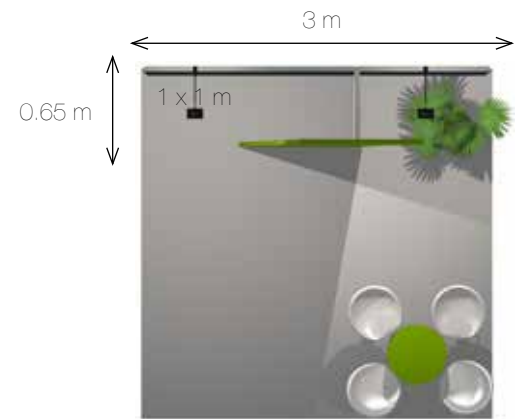

Height 3 m

# Backwall with a zigzag shape

9 m<sup>2</sup> exhibition stand



panoramic™

Structure + Graphic + 3 x (200 W) lights + Transport solution

purchase **£3 925**

rental **£2 057**

*\*excluding furniture* .....

Product name  
**PAN-STAND-3**

Transport solution

2 bags on wheels

Options\*

banner display



Zig-zag effect adds depth



(200 W) lights

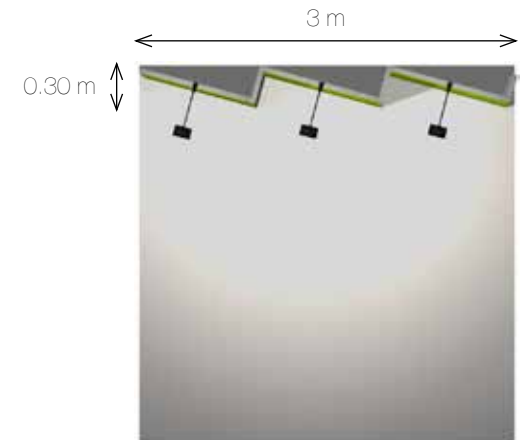

Standard height 2.5 m

# Curved L-shaped stand

9 m<sup>2</sup> exhibition stand



**panoramic™**

Structure + Graphic + 3 x (200 W) lights + Transport solution

purchase **£4 153**

rental **£2 527**

\*excluding furniture

Product name  
**PAN-STAND-8**

Transport solution

2 bags on wheels

Options\*

	purchase	rental
counter		
<b>PAN-COUNT-5</b>	<b>£833</b>	<b>£384</b>

brochure stand

3 m

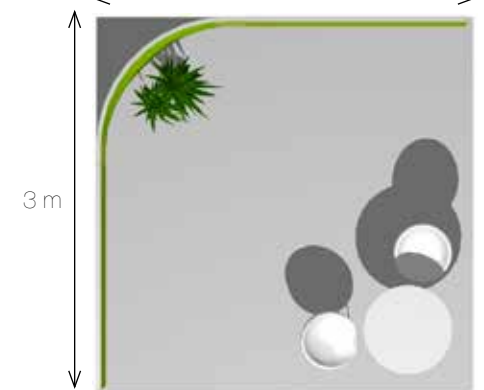

Standard height 2.5 m



Curved wide format graphic



(200 W) lights



Counter with interior shelf

# Backwall with front sign & storage

9 m<sup>2</sup> exhibition stand



panoramic™

Structure + Graphic + 3 x (200 W) lights + Transport solution

purchase £2 850

rental £1 727

Product name  
**PAN-STAND-7**

Transport solution

2 bags on wheels



Storage area



(200 W) lights

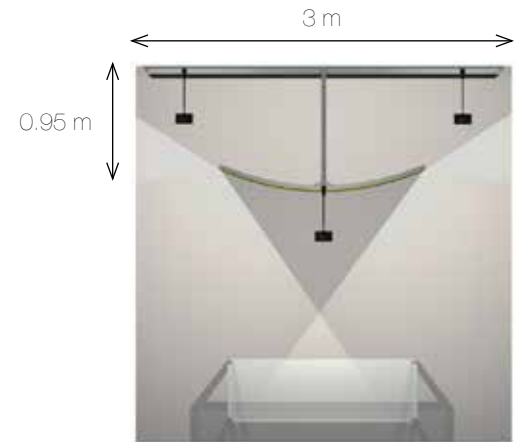

Standard height 2.5 m

# L-shaped stand with an adjustable wall

9 m<sup>2</sup> exhibition stand



Adjustable partition



Counter with interior shelf\*



(200 W) lights



Structure + Graphic + 3 x (200 W) lights + Transport solution

purchase £4 255

rental £2 646

Product name  
**PAN-STAND-11**

Transport solution

3 bags on wheels

Options\*

	purchase	rental
counter		
<b>PAN-COUNT-5</b>	<b>£833</b>	<b>£384</b>

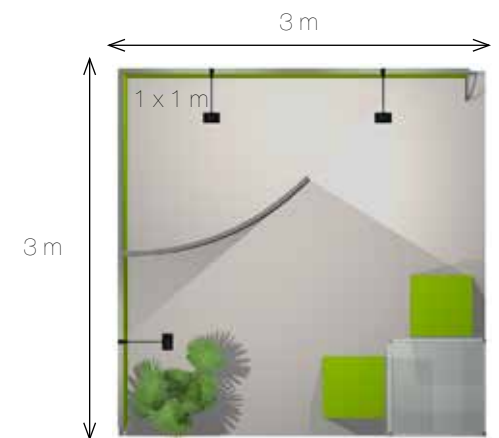

Standard height 2.5 m

# U-shaped stand

9 m<sup>2</sup> exhibition stand

Do it yourself



1 counter\*



Counter with interior shelf

panoramic™

Structure + Graphic + 6 x (200 W) lights + Transport solution

purchase £4 781

rental £3 023

\*excluding furniture

Product name  
**PAN-STAND-6**

Transport solution

3 bags on wheels

Options\*

	purchase	rental
counter		
<b>PAN-COUNT-5</b>	<b>£833</b>	<b>£384</b>

brochure stand

3 m

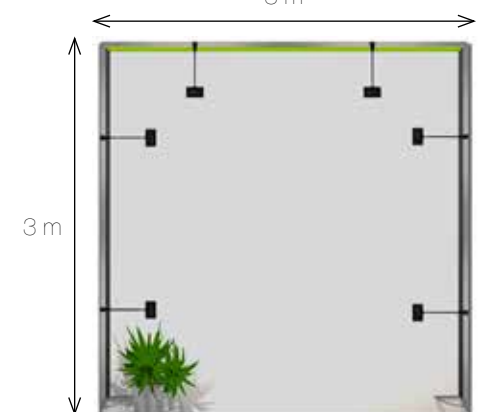

3 m

Standard height 2.5 m

# L-shaped stand with storage

9 m<sup>2</sup> exhibition stand



Structure + Graphic + 3 x (200 W) lights + Transport solution

purchase £5 614

rental £3 666

\*except Screen TV

Product name  
**PAN-STAND-4**

Transport solution

Stackable cases

Options\*

	purchase	rental
counter		
<b>PAN-COUNT-5</b>	<b>£833</b>	<b>£384</b>



Secure storage area



Counter with interior shelf\*



Monitor support (Screen 102 cm max, not included)

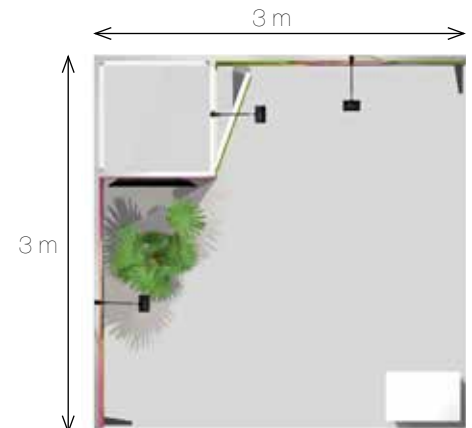

Standard height 2.5 m

# L-shaped multifunctional stand with top part, column & showcase

9 m<sup>2</sup> exhibition stand



Retractable display + Brochure stand\*

Column with cubbies and shelves



Sturdy shelves



Monitor support (Screen 102 cm max, not included)



Structure + Graphic + 3 x (200 W) lights + Transport solution

purchase £6 815

rental £4 114

\*excluding monitor

Product name  
**PAN-STAND-14**

Transport solution

Stackable cases

Options\*

retractable display

brochure stand

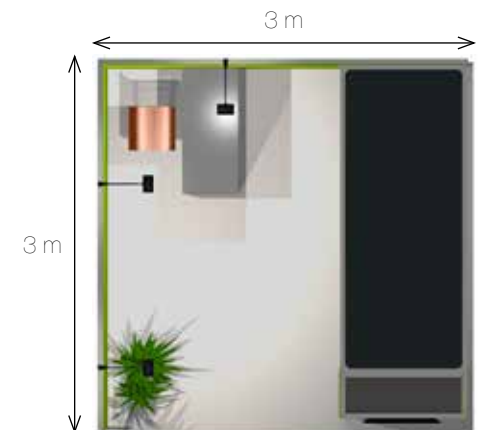

3 m

Standard height 2.5 m

# Free-standing backwall

12 m<sup>2</sup> exhibition stand



panoramic™

Structure + Graphic + 2 x (200 W) lights + Transport solution

purchase £2 159

rental £1 366

Product name  
**PAN-STAND-22**

Transport solution

1 bag on wheels



(200 W) lights



Arch foot



# Backwall with front sign & storage

12 m<sup>2</sup> exhibition stand



panoramic™

Structure + Graphic + 3 x (200 W) lights + Transport solution

purchase £3 195

rental £1 986

Product name  
**PAN-STAND-19**

Transport solution

2 bags on wheels



Open storage area



Stabilising foot



(200 W) lights

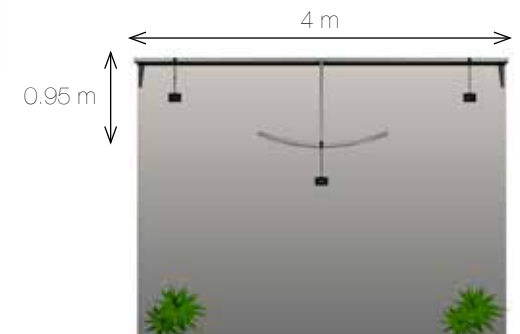

Standard height 2.5 m

# Backwall with front sign & storage

12 m<sup>2</sup> exhibition stand



Structure + Graphic + 2 x (200 W) lights + Transport solution

purchase £4 012

rental £2 347

Product name  
**PAN-STAND-16**

Transport solution

2 bags on wheels

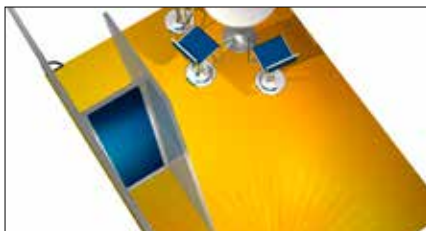

Open storage area



Sleek frame & billboard-style panel



Small footprint

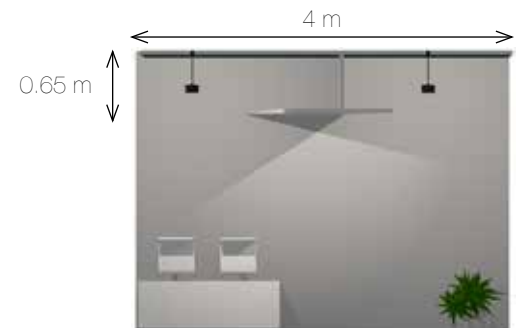

Height 3 m

# L-shaped stand

12 m<sup>2</sup> exhibition stand



panoramic™

Structure + Graphic +  
2 eco lights + Transport  
solution

purchase £4 075

rental £2 505

Product name  
**PAN-STAND-20**

Transport solution

3 bags on wheels



Invisible structure



Monitor support (Screen 102 cm max, not included)

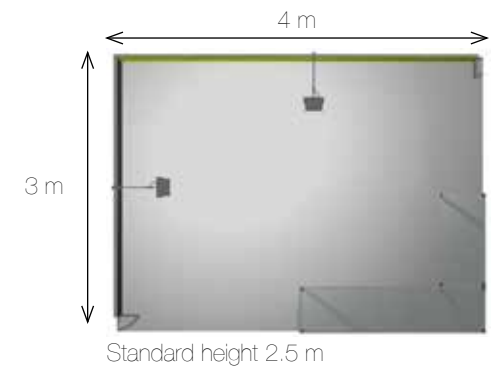

# L-shaped stand with adjustable wall

12 m<sup>2</sup> exhibition stand



Structure + Graphic + 4 x (200 W) lights + Transport solution

purchase £4 781

rental £2 984

\*excluding furniture

Product name  
**PAN-STAND-12**

Transport solution

3 bags on wheels

Options\*

	purchase	rental
counter		
<b>PAN-COUNT-1</b>	<b>£1 138</b>	<b>£549</b>



Adjustable partition



Counter with interior shelf (counter shelf color: please contact us for more information)\*



Elegant design

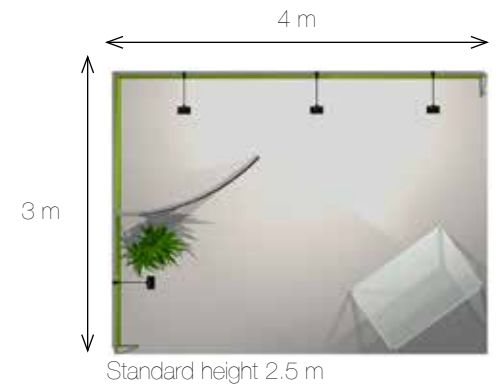

# Curved stand with storage

12 m<sup>2</sup> exhibition stand



**panoramic™**

Structure + Graphic + 3 x (200 W) lights + Transport solution

purchase **£5 182**

rental **£2 984**

Product name  
**PAN-STAND-17**

Transport solution

Stackable cases

Options\*

	purchase	rental
counter		
<b>PAN-COUNT-3</b>	<b>£1 578</b>	<b>£816</b>

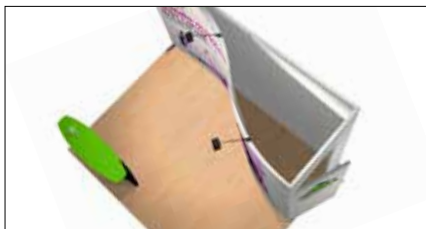

Secure storage area



S counter with double-sided graphics\*



Elegant design

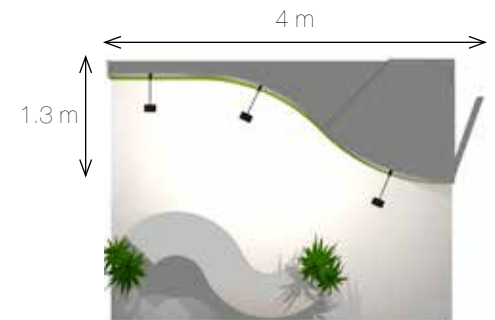

Standard height 2.5 m

# Curved L-shaped stand with storage

12 m<sup>2</sup> exhibition stand



panoramic™

Structure + Graphic + 4 x (200 W) lights + Transport solution

purchase £5 936

rental £3 407

Product name  
**PAN-STAND-18**

Transport solution

Stackable cases



Secure storage area

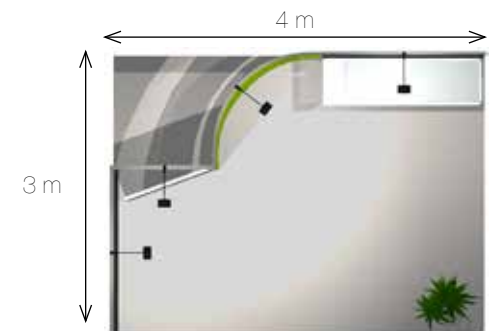

Standard height 2.5 m

# Backwall with two columns with cubbies & shelves

12 m<sup>2</sup> exhibition stand



2 sturdy shelves



Counter with interior shelf\*



Eco light

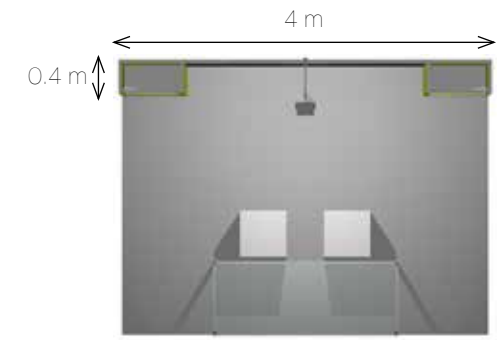

standard height 2.5 m

panoramic™

Structure + Graphic +  
1 Eco light + Transport  
solution

purchase £6 185

rental £3 447

\*excluding furniture

Product name  
**PAN-STAND-21**

Transport solution

Stackable cases

Options\*

	purchase	rental
counter		
<b>PAN-COUNT-1</b>	<b>£1 138</b>	<b>£549</b>

# U-shaped stand with adjustable wall



Structure + Graphic + 5 x (200 W) lights + Transport solution

purchase **£6 257**

rental **£3 902**

\*excluding furniture & TV screen -----

Product name  
**PAN-STAND-23**

Transport solution

4 bags on wheels

Options\*

brochure stand

12 m<sup>2</sup> exhibition stand

Open storage area

Do it yourself

Monitor support\*



Adjustable partition



Monitor support



(200 W) lights

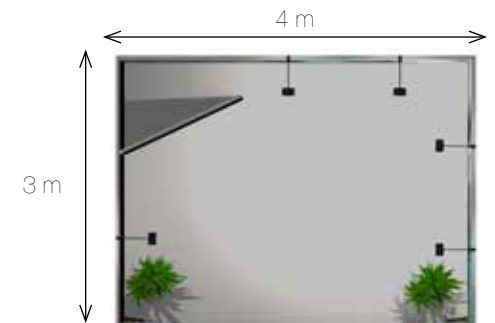

Standard height 2.5 m

# L-shaped multifunctional stand with top part, column & showcase

12 m<sup>2</sup> exhibition stand

panoramic™

Structure + Graphic + 3 x (200 W) lights + Transport solution

purchase £7 129

rental £4 366

\*excluding furniture & TV screen .....

Product name  
**PAN-STAND-13**

Transport solution

Stackable cases

Options\*

	purchase	rental
counter		
<b>PAN-COUNT-1</b>	<b>£1 138</b>	<b>£549</b>

brochure stand

retractable display



Brochure stand\*

Retractable display\*  
+ light

Column with cubbies  
and shelves



Sturdy shelves



Monitor support (Screen 102 cm max, not included)

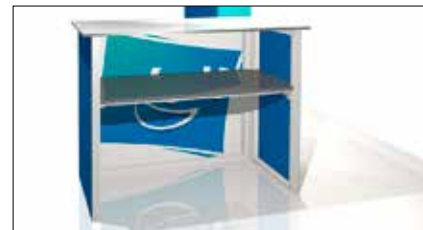

Counter with interior shelf



# L-shaped stand with storage

12 m<sup>2</sup> exhibition stand



**panoramic™**

Structure + Graphic + 3 x (200 W) lights + Transport solution

purchase **£6 368**

rental **£3 690**

\*excluding furniture

Product name  
**PAN-STAND-9**

Transport solution

Stackable cases

Options\*

	purchase	rental
counter		
<b>PAN-COUNT-5</b>	<b>£934</b>	<b>£440</b>

brochure stand



Secure storage area 1 x 1 m



4-sided counter wrap\*



Monitor support (Screen 102 cm max, not included)



3 m

4 m

Standard height 2.5 m

# Broaden your horizons — 18 m<sup>2</sup>

18 m<sup>2</sup> exhibition stand

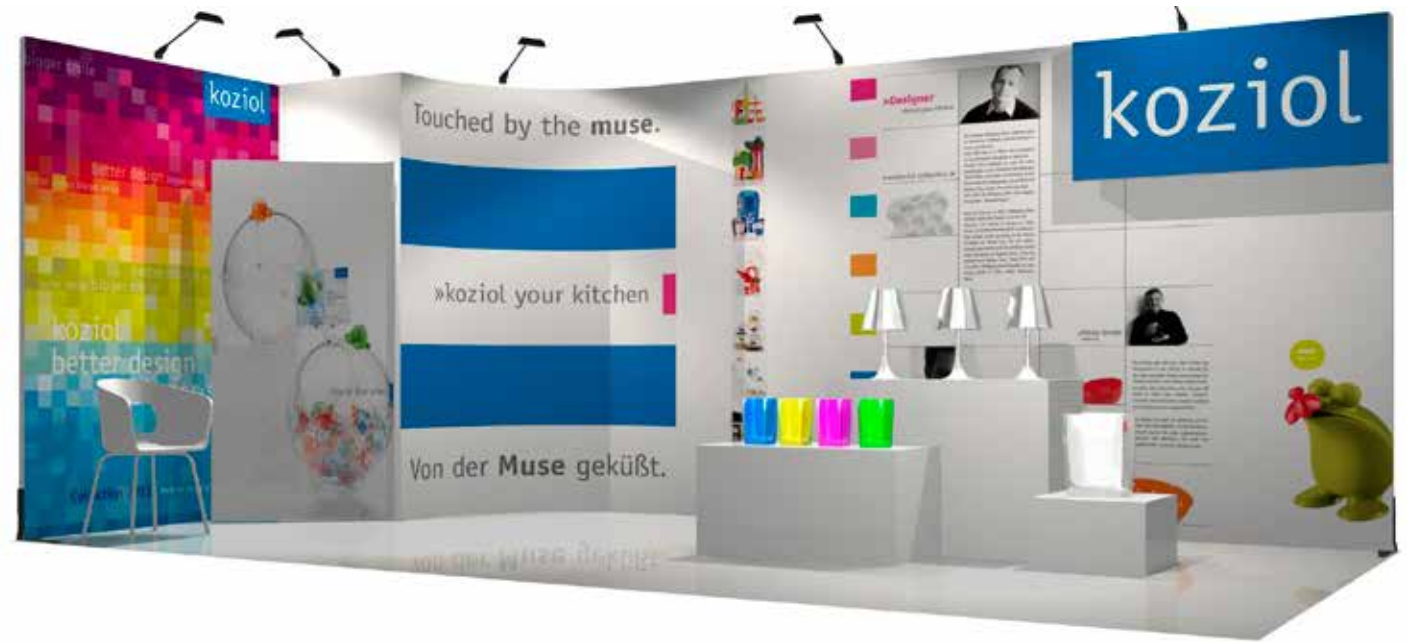

- + Expand your marketing creativity with more space and a wide surface to promote your message
- + All kits are delivered with everything you need: structure, graphics, lights, carrying cases
- + Wide range of accessories available, including shelves, brochure stand, monitor mounts, backlighting, and more

# Free-standing backwall

18 m<sup>2</sup> exhibition stand

Do it yourself

(200 W)\* lights



Self-standing frame

panoramic™

Structure + Graphic + 4 x (200 W) lights + Transport solution

purchase £3 157

rental £2 010

\*excluding furniture & multimedia

Product name  
**PAN-STAND-27**

Transport solution

1 bag on wheels



(200 W) lights



Peanut-shaped base



Standard height 2.5 m

# L-shaped stand

18 m<sup>2</sup> exhibition stand

Do it yourself

Eco Lights



2 counters\*

panoramic™

Structure + Graphic +  
3 Eco lights + Transport  
solution

purchase £4 867

rental £3 070

\*excluding furniture & multimedia .....

Product name  
**PAN-STAND-26**

Transport solution

3 bags on wheels

Options\*

	purchase	rental
counter (unit price)		
<b>PAN-COUNT-6</b>	<b>£934</b>	<b>£440</b>



4-sided counters wrap



No visible profiles

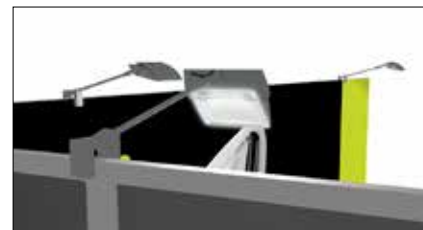

Eco lights

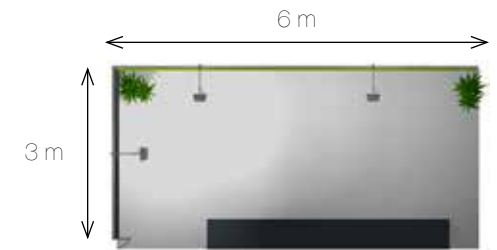

Standard height 2.5 m

# Stand with central storage

18 m<sup>2</sup> exhibition stand



Structure + Graphic +  
3 Eco lights + Transport  
solution

purchase £5 355

rental £3 203

\*excluding furniture & multimedia

Product name  
**PAN-STAND-30**

Transport solution

Stackable cases

Options\*

	purchase	rental
counter (unit price)		
<b>PAN-COUNT-6</b>	<b>£934</b>	<b>£440</b>



Secure storage area (stand connected to closed-off back portion)\*



Small footprint



Counter with 4-sided graphic

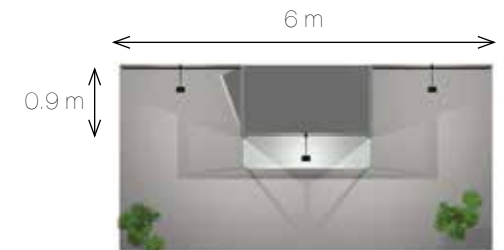

Standard height 2.5 m

# Curved stand with storage

18 m<sup>2</sup> exhibition stand



Structure + Graphic + 4 x (200 W) lights + Transport solution

purchase £6 352

rental £3 675

\*excluding furniture & multimedia .....

Product name  
**PAN-STAND-24**

Transport solution

Stackable cases

Options\*

	purchase	rental
counter		
<b>PAN-COUNT-1</b>	<b>£1 138</b>	<b>£549</b>

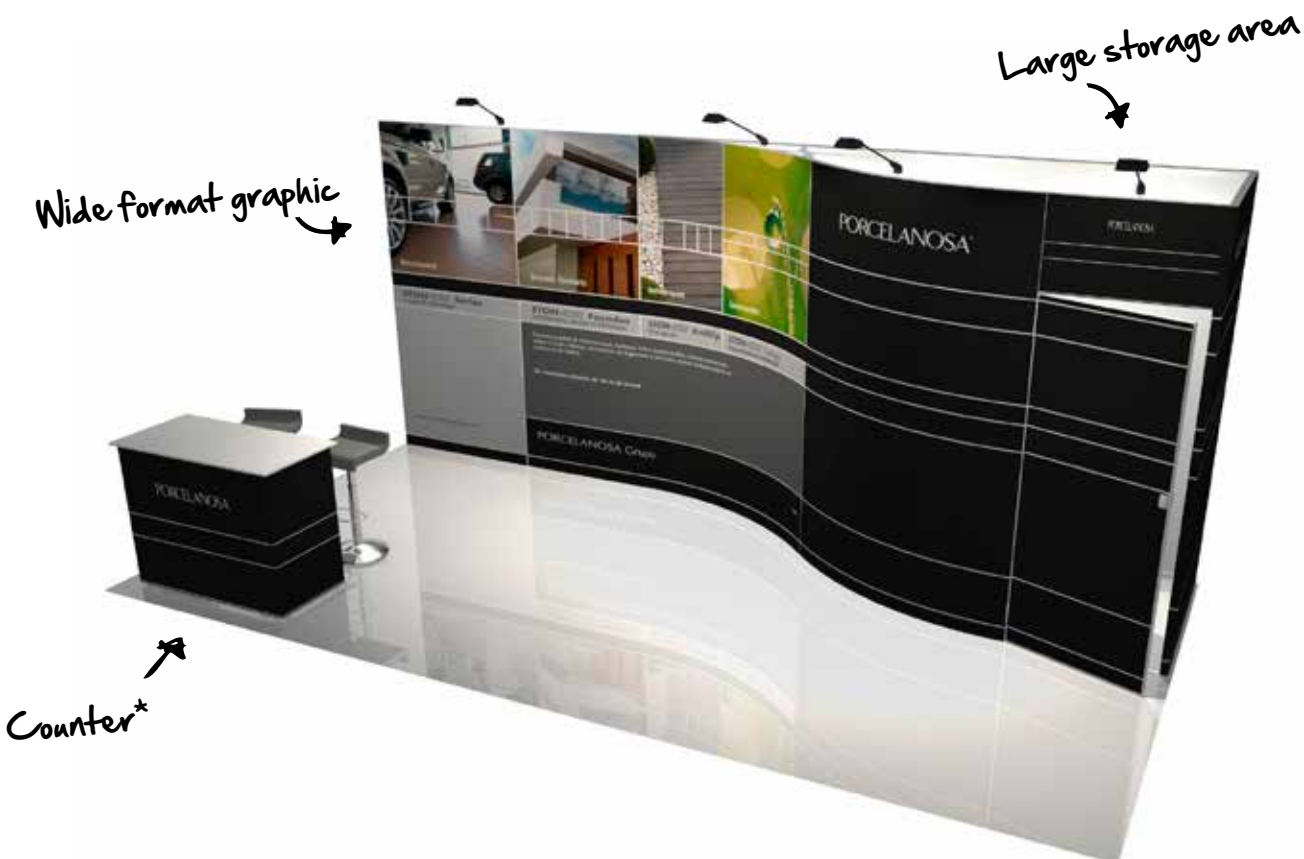

Secure storage area

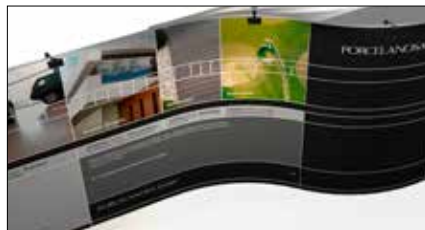

Elegant design



Counter with interior shelf



Standard height 2.5 m

# Curved L-shaped stand with storage

18 m<sup>2</sup> exhibition stand



Structure + Graphic + 5 x (200 W) lights + Transport solution

purchase £ **6 603**  
 rental £ **3 934**

\*excluding furniture & multimedia

Product name  
**PAN-STAND-25**

Transport solution

Stackable cases

Options\*

	purchase	rental
1500 x 800 frame		
<b>FRAME</b>	<b>£220</b>	not available



Secure storage area (stand connected to closed-off back portion)\*



Rounded angle = higher visual impact



Mercure frame

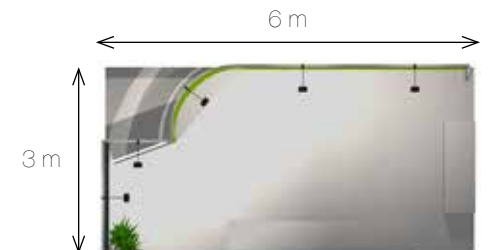

Standard height 2.5 m

# L-shaped multifunctional stand with top part, column & showcase



Structure + Graphic + 4 x (200 W) lights + Transport solution

purchase £8 487

rental £4 962

\*excluding furniture & TV screen

Product name  
**PAN-STAND-5**

Transport solution

Stackable cases

Options\*

	purchase	rental
counter		
<b>PAN-COUNT-3</b>	<b>£1 578</b>	<b>£816</b>

18 m<sup>2</sup> exhibition stand



Secure storage area



Sturdy shelves



Monitor support (Screen 102 cm max, not included)

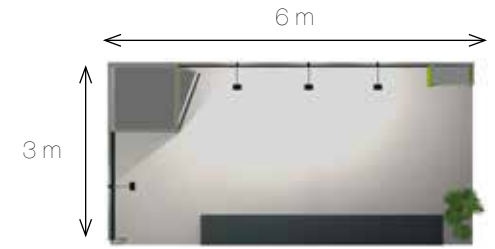

Standard height 2.5 m

# L-shaped stand with storage



Structure + Graphic + 4 x (200 W) lights + Transport solution

purchase £6 870

rental £4 962

\*excluding furniture & multimedia

Product name  
**PAN-STAND-34**

Transport solution

Stackable cases

18 m<sup>2</sup> exhibition stand

Monitor support

Secure storage area



Secure storage area



Monitor support (Screen 102 cm max, not included)



(200 W) lights

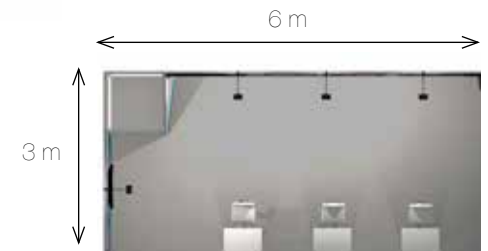

Standard height 2.5 m

# Curved stand with storage

18 m<sup>2</sup> exhibition stand



Structure + Graphic +  
3 x Eco lights + Transport  
solution

purchase £7 679

rental £4 530

\*excluding furniture & multimedia .....

Product name  
**PAN-STAND-32**

Transport solution

Stackable cases

Options\*

	purchase	rental
counter (unit price)		
<b>PAN-COUNT-1</b>	<b>£1 138</b>	<b>£549</b>

Retractable display

brochure holder

Curved structure +  
1 wide-format graphic

Secure storage area

2 Retractable displays\*

2 counters\*  
1 brochure holder\*



Secure storage area 1 x 1 m



Counter with interior shelf



Curved structure

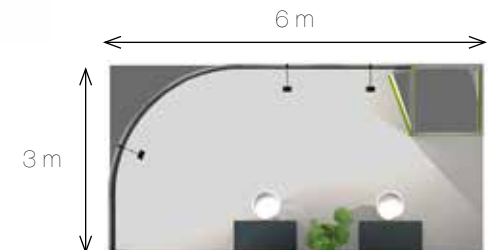

Standard height 2.5 m

# U-shaped stand with storage

18 m<sup>2</sup> exhibition stand



Structure + Graphic + 6 x (200 W) lights + Transport solution

purchase £8 660

rental £5 284

\*excluding furniture & multimedia

Product name  
**PAN-STAND-31**

Transport solution

Stackable cases

Options\*

	purchase	rental
counter (unit price)		
<b>PAN-COUNT-5</b>	<b>£833</b>	<b>£384</b>



Secure storage area



Monitor support (Screen 102 cm max, not included)



Counters with interior shelves



Standard height 2.5 m

# Stand in two parts with storage



Structure + Graphic + 3 x (200 W) lights + Transport solution

purchase **£8 809**

rental **£4 860**

\*excluding furniture & TV screen

Product name  
**PAN-STAND-29**

Transport solution

Stackable cases

Options\*

	purchase	rental
counter (unit price)		
<b>PAN-COUNT-6</b>	<b>£934</b>	<b>£440</b>

18 m<sup>2</sup> exhibition stand



Central storage area. (stand backed by an existing partition)\*



4-sided counter wrap



Monitor support (Screen 102 cm max, not included)



Standard height 2.5 m

# Multifunctional stand with storage, top part, column & showcase



Structure + Graphic + 6 x (200 W) lights + Transport solution

purchase £10 631

rental £6 422

\*excluding furniture & Screen TV .....

Product name  
**PAN-STAND-28**

Transport solution

Stackable cases

Options\*

	purchase	rental
counter		
<b>PAN-COUNT-1</b>	<b>£1 138</b>	<b>£549</b>

18 m<sup>2</sup> exhibition stand

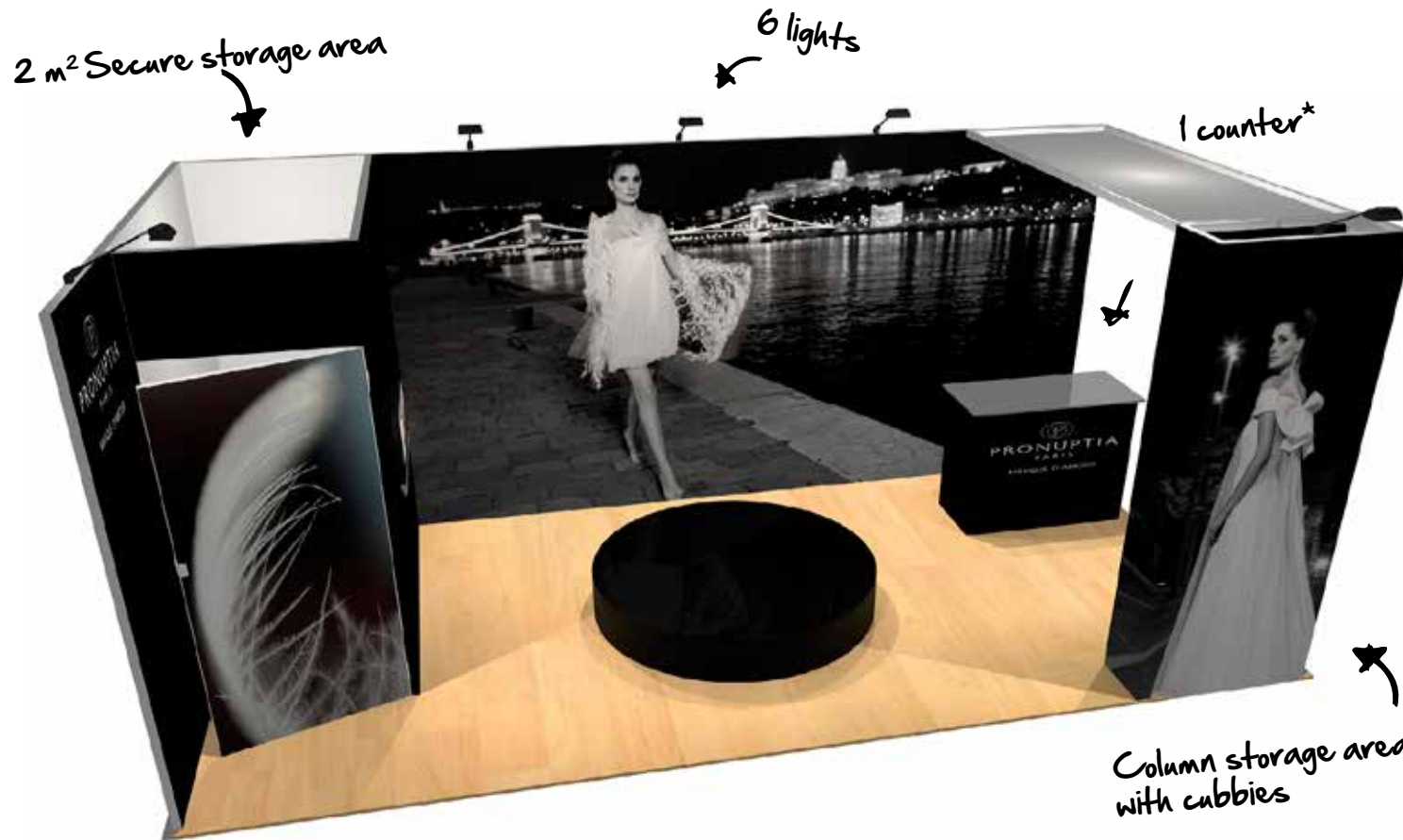

Secure storage area 2 x 1 m



Sturdy shelves



Monitor support (Screen 102 cm max, not included)

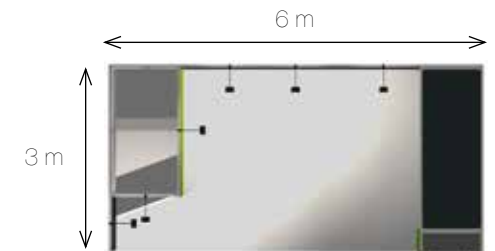

Standard height 2.5 m

# Triangular island stand with storage

18 m<sup>2</sup> exhibition stand



Structure + Graphic + 3 x (200 W) lights + Transport solution

purchase **£5 723**

rental **£3 502**

\*excluding furniture & multimedia

Product name  
**PAN-STAND-33**

Transport solution

Stackable cases

Options\*

	purchase	rental
Hanging sign		
<b>HANGING SIGN</b>	<b>£2 889</b>	<b>£1 618</b>

light box (unit price)		
<b>PAN-MODULE-1</b>	<b>£1 884</b>	<b>£887</b>

Retractable display



Spacious and Secure storage area



Hanging sign 1 m (optional)



Light boxes (optional)

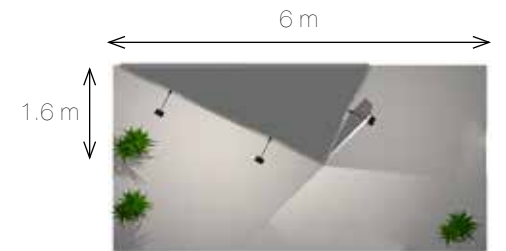

Standard height 2.5 m excluding sign board

# Light boxes — put the spotlight on your message!

## Light boxes



- + 100% environmentally-friendly: LED lighting system consumes a very low amount of electricity
- + 100% portable: LED light blanket on flexible fabric for more economical transport.
- + 100% effective: high-definition dye-sublimation printing
- + 100% ready to use: no tools required for set-up

# Light boxes — put the spotlight on your message!

Light boxes



Structure + Graphic

purchase £1 884

rental £887

Product name

**PAN-MODULE-1**

Graphic specs

1000 x 2000 mm

# Counters — welcome and invite!



Counters



- + A range of elegant counters with no visible framework, fully covered in customized printed fabric
- + Counter tops and shelves in laminate in order to withstand many set-ups and dismantles
- + Available features (optional for some kits): interior shelves, vase holder. For custom shape for shelf or top, please contact us.

# Counters — welcome and invite!

Counters



Structure + Graphic + Counter top +  
Shelve + Transport solution

purchase £**833**

rental £**384**

\*excluding furniture.....

Product name  
**PAN-COUNT-5**

Dimensions incl. counter top  
D 400 x L 600 x H 1025



Structure + Graphic + Counter top  
+ Transport solution

purchase £**934**

rental £**440**

\*excluding furniture.....

Product name  
**PAN-COUNT-6**

Dimensions incl. counter top  
D 550 x L 550 x H 1025



Structure + Graphic + Counter top +  
Shelf + Transport solution

purchase £**1 138**

rental £**549**

\*excluding furniture & multimedia.....

Product name  
**PAN-COUNT-1**

Dimensions incl. counter top  
D 600 x L 1200 x H 1025

# Counters — welcome and invite!

Counters

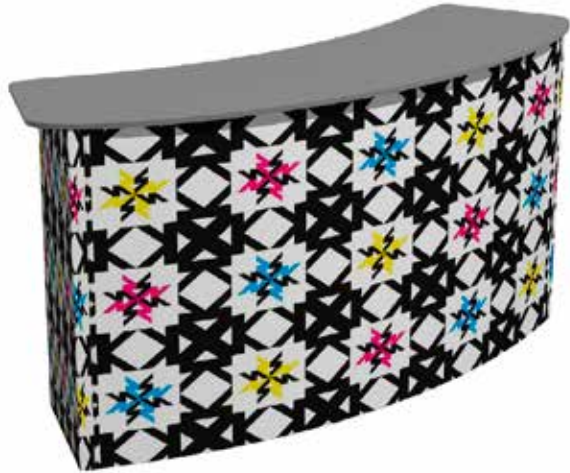

Structure + Graphic + Counter top  
+ Transport solution

purchase **£1 555**  
rental **£738**

Product name  
**PAN-COUNT-7**

Dimensions incl. counter top  
D 460 x L 1842 x H 1025



Structure + Graphic + Counter top  
+ Transport solution

purchase **£1 578**  
rental **£816**

\*excluding decoration

Product name  
**PAN-COUNT-3**

Dimensions incl. counter top  
D 450 x L 1600 x H 1025



Structure + Graphic + Counter top  
+ Shelf + Transport solution

purchase **£1 602**  
rental **£770**

Product name  
**PAN-COUNT-4**

Dimensions incl. counter top  
D 711 x L 1842 x H 1025



# Benefits of fabric graphics

Fabric graphics are easy to transport, install and handle. They are wrinkle and stain resistant and can even be dry-cleaned. Fabric fibers are dyed directly during the dye-sublimation printing process, which improves the durability of colors over time

## Benefits of dye-sublimation printing

Sublimation is the process by which a solid changes directly into a gas. The fabric fibers are dyed directly, which improves the durability of colors over time.

### Advantages

- + Intense colors: dye-sub offers unparalleled quality of contrast, intensity, and depth
- + Anti-reflective: sublimated fabric absorbs light and thus eliminates any reflections on your image
- + Eco-friendly process: the printing process and its inks are environmentally-friendly solutions that do not contain solvents and are free of unpleasant odors.





## What is SEG?

SEG (Silicone Edge Graphic) is the combination of a dye-sublimation fabric graphic with a thin silicone strip sewn directly to its edges. This strip is inserted into the groove of our Aluminium frames to produce a seamless, large format graphic that mimics the old-fashioned rigid panel graphics commonly found with exhibits and interior signage.

## Why choose SEG?

- + Quicker set-up = lower labor costs. SEG graphics are easy to install and dismantle
- + Lightweight = lower shipping & drayage costs. SEG graphics weigh significantly less than other print media, making them easy to carry, ship, and store
- + Seamless and polished finish. SEG graphics stretch taut over the frame without any seams, lines, or wrinkles to create a very high-quality appearance for your booth

# Artwork guidelines

Our design team helps you create your artwork. If you would like to create it yourself, we will supply you with templates and measurements. Please follow the instructions below to ensure a high quality graphic.

## + **Templates**

Use our artwork templates to ensure the measurements are correct.

## + **File format**

PDF. Save the file as “Press Quality No Downsampling”. All fonts should be vectorized.

## + **Image resolution**

Included images should have at least 100 dpi resolution on a scale of 1:1.

## + **Colours**

Use CMYK or PMS colours.

For best blackness, use 20 % cyan, magenta and yellow.

RGB colours are not accepted.

Please follow the above instructions for optimal print production. If not followed, we cannot be held responsible for the print quality. If adjustment of your original file is required, it will include an extra fee.



**Learn more about the Panoramic exhibition stands:  
[www.expandmedia.com](http://www.expandmedia.com)**

Expand International AB  
Palmfeltsvagen 1C  
SE-121 62 Johanneshov, **Sweden**  
Tel +46 (0) 8 55 69 69 40, Fax+46 8 (0) 55 69 69 01  
E-mail [info@expandmedia.com](mailto:info@expandmedia.com)

Expand International Deutschland GmbH  
Holzstraße 2  
40221 Düsseldorf, **Germany**  
Tel: +49 (0)211-220597-0 Fax: +49 (0)211-220597-79  
E-mail [info.de@expandmedia.com](mailto:info.de@expandmedia.com)

Expand International (GB) Ltd.  
Unit 1, Saxon Business Centre, Windsor Avenue, Merton  
London SW19 2RR, **UK**  
Tel +44 (0)208 540 8800 Fax +44 (0)208 540 0500  
E-mail [info.uk@expandmedia.com](mailto:info.uk@expandmedia.com)

Display France Sarl  
Parc d'affaires de Limonest  
1 rue des Vergers - Bât. 5  
FR-69760 Limonest, **France**  
Tel +33 4 78 66 47 30, Fax +33 4 78 66 47 39  
E-mail [france@expandmedia.com](mailto:france@expandmedia.com)



[expandmedia.com](http://expandmedia.com)