

Flyte Coupler

BULK RAIL FUELLING COUPLER

Screw connect dry break coupler for bulk rail fuelling applications



Features and Benefits:

- Flow rates from 50—650 litres per minute provide optimum fuelling times
- Screw connect dry break valve allows safe & easy connection to fuel tanks
- 1 1/2" bspf inlet compatible with most commonly used train refuelling hoses
- Viton seals provide full resistance to all existing and new fuel blends
- High impact steel body for durability and strength
- Corrosion resistant coating for long working life
- Durable forged steel handle give excellent levels of operator control
- Unique hex socket fitting allows fast and easy installation
- Interchangeable with all existing rail couplers
- Easy replacement cartridge, quick servicing and short down time

S1010D Datasheet

LIQUID HANDLING SOLUTIONS

www.IFCinflow.com

Leaders in liquid handling systems

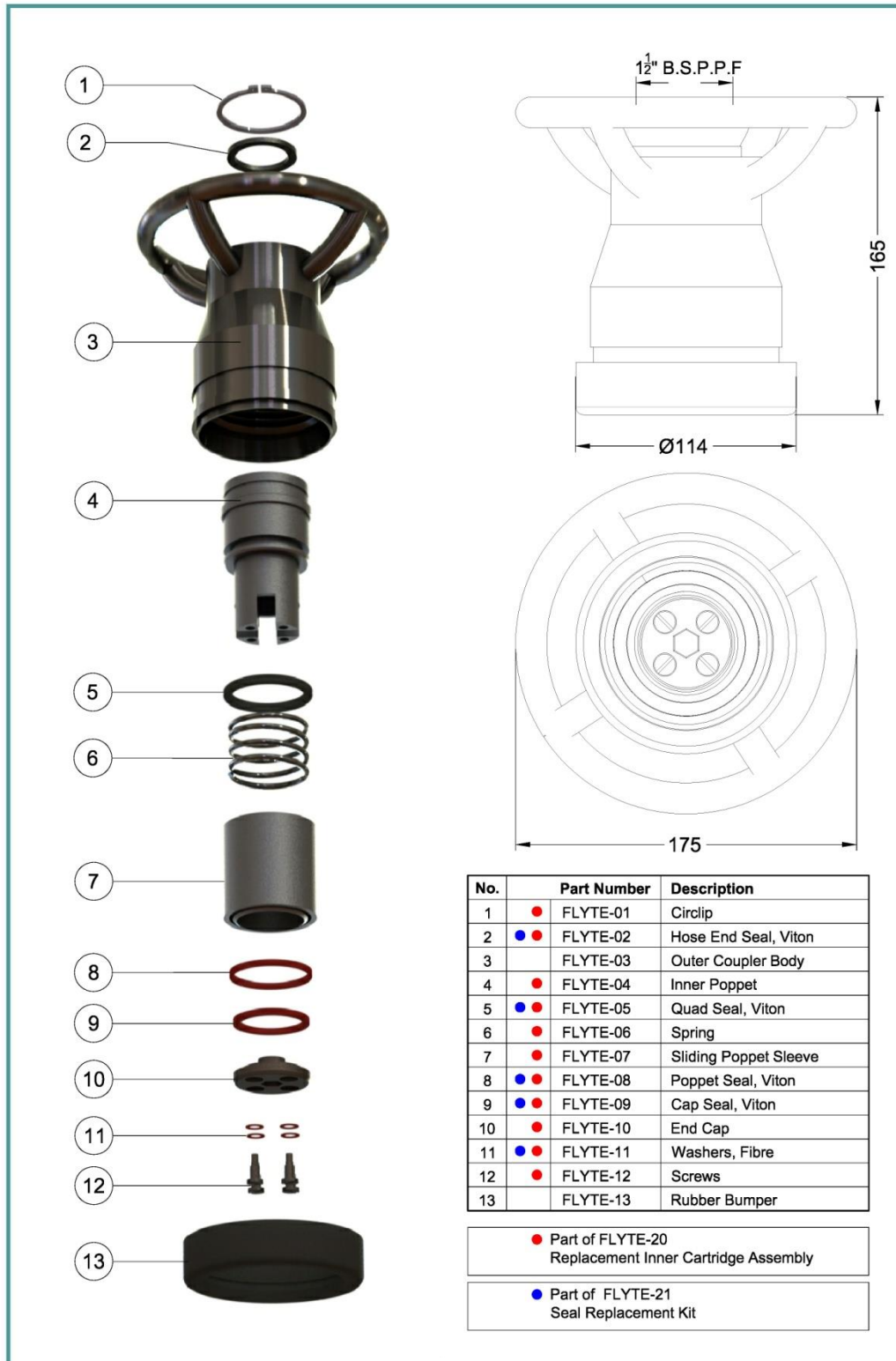

For all **YOUR** liquid handling solutions



INDUSTRIAL FLOW CONTROL LTD, 3 RYDER WAY, BASILDON, ESSEX. SS13 1QH. UK

T: +44 1268 596900 E: sales@IFCinflow.com