

PRODUCT RANGE



Our strength is our versatility

PennyHydraulics



“ I would just like to say thank you very much to everybody at Penny Hydraulics. The crane is fantastic and I am sure it will be very useful. Also thank you for such quick service doing the change-over crane. Your customer service is the best we have ever known and we will be highly recommending you and your products. ”

Matthew Dungey,
I G Dungey & Son

Inside... 4. **SwingLift** cranes | 26. **TailLift** platforms | 30. **SideLift** platforms | 32. **StepLift** platforms | 34. **LoadLift** platforms
40. **GridLift** | 42. **TyrePress** | 44. Winches | 45. Special applications & accessories | 48. **MezzLift** | 50. Service, training and on-site fitting



Penny Hydraulics has been designing and manufacturing bespoke lifting solutions for more than thirty years. In this time we have developed a wide range of vehicle-mounted cranes and platforms, many of which were the result of our customers approaching us and saying “we need something that will lift...”. These solutions have in turn gone on to become market-leading products.

Our **SwingLift** range of cranes start with capacities of 100kg and bespoke boom lengths to suit small car-derived vans up to models with over four metres boom reach and capacities of over 2000kg. Although already well specified, you can choose additional features from our extensive options lists - manual or hydraulic slewing, full wireless remote control, additional pillar and rope lengths and hydraulic or electric winches. All are ideal for pickups, dropsides, flatbeds or vans and provide low-cost, reliable service and proven durability.

Other products include the lightweight, aluminium 500kg capacity Davit Cranes, specially designed to be demountable and portable for hard-to-reach sites; track-mounted **SwingLifts** which are ideal for both indoor and outdoor applications where the ability to “lift and shift” can prove both cost effective and improves efficiency; and the new **GridLift** for the safe and efficient cleaning of highway gullies.

Then there is a wide range of loading platforms from 250kg capacity up to 500kg including the **LoadLift** as used by Royal Mail for moving containerised mail; the **SideLift** used by local authorities and tyre companies for kerbside deliveries; the single and multi-fold **StepLift** designed to replace the rear step on most van types; and the 500kg capacity Easyloader **TailLift**.

These compact and durable devices are suitable for almost all commercial vehicles. Again, where applicable, a wide range of options are available including a choice of steel, mesh or aluminium platforms, wireless remote control, bespoke platform widths, anti-roll-off toes, reversing sensors and guard rails.

In addition to our vehicle-mounted solutions and if you need to move goods safely and efficiently between two (or more) floors, we have the **MezzLift** range of vertical platform lifts. These are in use in many factories, stores and tyre depots. And for the handling of drinks and foodstuffs we are pleased to supply many of the leading brewing companies, hotel and restaurant chains with our **CellarLift** range of delivery hoists - please ask us for our separate brochures covering these products.

Our customer base ranges from sole traders with one vehicle to the largest fleet in Europe and to the major rail, utility, highway, tyre and telecommunications companies. We are also proud to be approved converters for some of the largest commercial vehicle manufacturers including Renault and Nissan, which means you can order your lifting equipment at source.

We understand that you need the peace-of-mind of a planned maintenance programme in order to achieve full compliance with European legislation. We offer a choice of extremely cost-effective service packages which include examination and testing to ensure reliable service throughout the life of your investment and compliance with statutory legislation. Additional support is offered in the form of our on-site fitting and training services - please see page 50 for more details.

Finally, all of our products are designed, developed and manufactured to stringent European quality and safety standards at our purpose-built UK facility. You are always welcome to come and see our operation first hand.

Whether you need a 250kg capacity platform lift for a single vehicle, a 2000kg capacity crane for an entire fleet or even something that doesn't yet exist, talk to us... and discover the versatility that is the strength of Penny Hydraulics.

For maximum flexibility



Specially designed to be fitted to any vehicle these knuckle-joint cranes offer complete flexibility allowing loads to be positioned accurately anywhere within their radius. Available with a 1 or 1.5 metre radius.

Features

- Lifts up to 250kg – ideal for gas bottles and small items of plant
- Overload device – will not lift more than MWL
- Low crane weight of approximately 31-34kg
- Compact design maximising vehicle floor space
- Fully demountable – can be deployed on other vehicles or removed altogether, therefore maintaining maximum fleet flexibility
- Can be re-fitted to new replacement vehicles
- Easy to operate one-man operation with minimal moving parts
- Easy to maintain and with long service intervals

Options

- Bespoke boom length to suit application
- 100kg and 150kg versions also available
- 12v or 24v operation from vehicle battery
- Radio remote control
- Corner bracket for mounting direct to a pick-up vehicle headboard
- Cranked hinge available allowing even greater flexibility
- Additional pillar height
- Extra rope length – 9m/30' up to 250kg
- Battery protection
- Lifting accessory kit



Applications

- Highways
- Construction
- Utilities
- Fire & rescue

KJ250/1

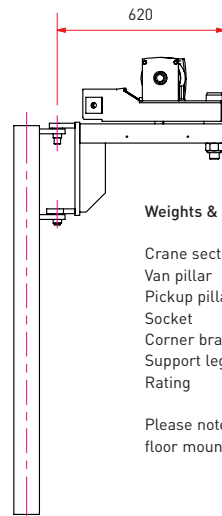
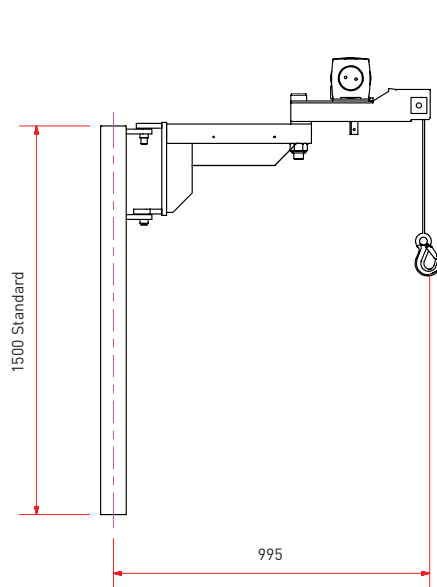

Weights & measurements

Crane section	31kg
Van pillar	25kg
Pickup pillar	18kg
Socket	17kg
Corner bracket	5.5kg
Support leg	8kg
Rating	0.25 tonne metres

Please note that an above or below floor mounting socket is available.

KJ250/1.5

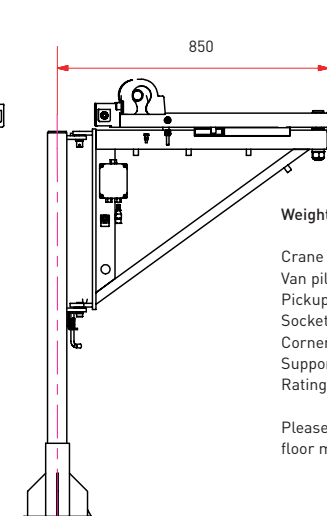
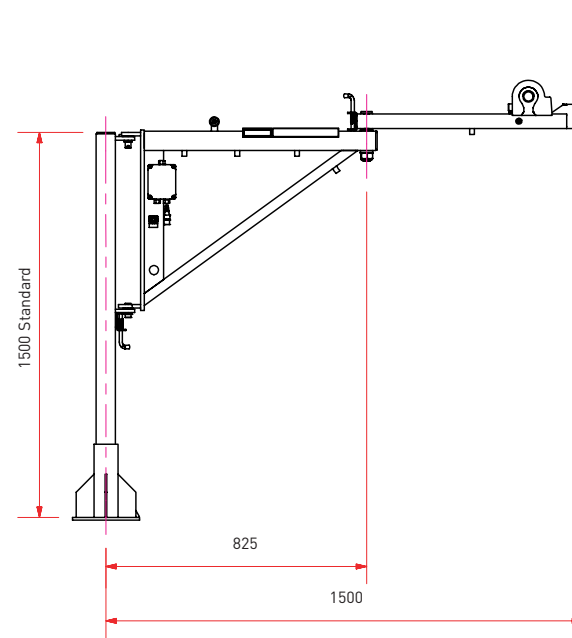

Weights & measurements

Crane section	34kg
Van pillar	25kg
Pickup pillar	18kg
Socket	17kg
Corner bracket	5.5kg
Support leg	8kg
Rating	0.375 tonne metres

Please note that an above or below floor mounting socket is available.



The complete solution

The new KJ250/2 is a two metre knuckle-joint crane offering a complete handling solution, combining simplicity, reliability and proven durability. It provides a safe, efficient and cost-effective means of handling loads for all types of vehicle.

Features

- Lifts up to 250kg ideal for kerb stones and posts
- 2 metre boom plus 2 pivot points means operator can carry out lifts within a 4 metre radius
- Overload device - will not lift more than MWL
- Low crane weight of approximately 92kg
- Compact design maximising vehicle floor space
- Fully demountable - can be deployed on other vehicles or removed altogether, therefore maintaining maximum fleet flexibility
- Can be re-fitted to new replacement vehicles
- Easy to operate - RPT version can be deployed and operated from ground level
- Versatile - can be used to lift other equipment such as whacker plates and compressors

Options

- 150kg version also available
- 12v or 24v operation from vehicle battery
- Radio remote control
- Above or below floor socket mount
- Corner bracket for mounting direct to headboard
- Additional pillar height
- Extra rope length - 9m/30' up to 250kg
- Battery protection
- Lifting accessory kit



Applications

- Highways
- Construction
- Utilities
- Fire & rescue

KJ250/2 GHT

180° slew - can also be headboard mounted

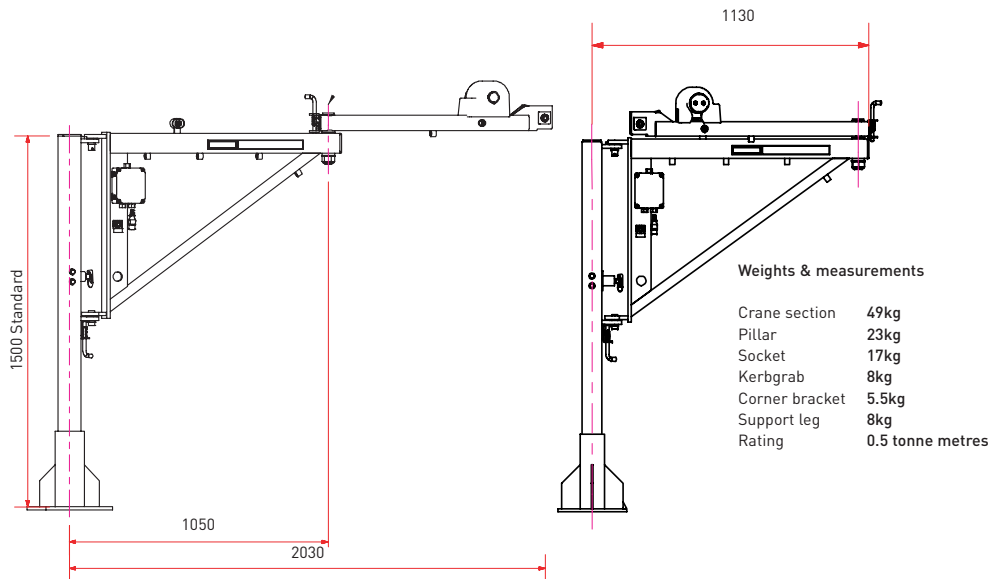

KJ250/2 RPT

360° slew - ideally suited for mounting on rear of vehicle

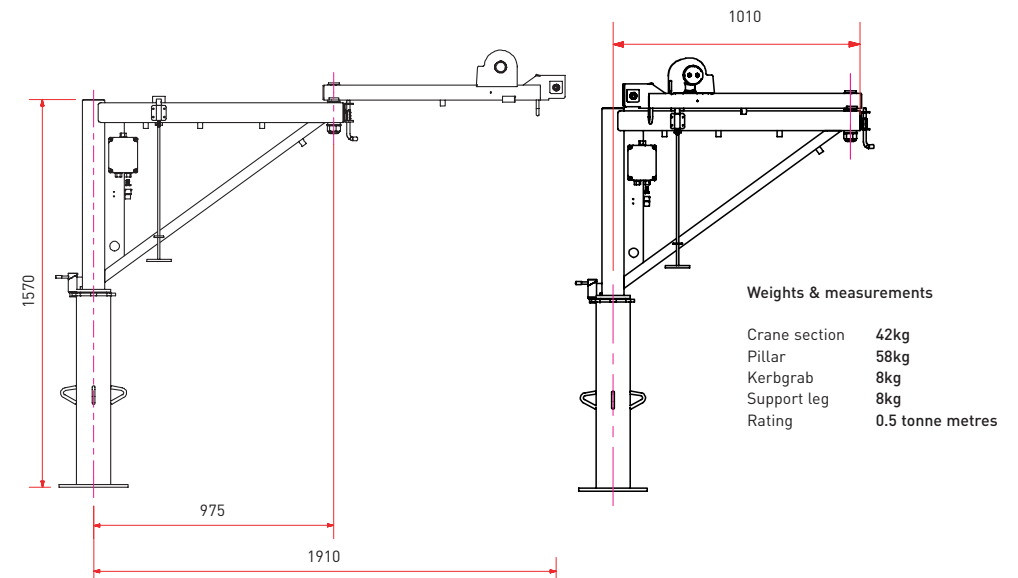

The lightweight heavyweight



Features

- Lifts 250kg in all configurations of boom position
- Remote control
- Easily demountable
- Low crane weight from 23kg
- Lightweight pillar available for vans
- Above or below floor socket mounting for pick-ups
- Overload protection
- Compact design folds away when not in use
- Easily installed at our own premises, on site or by a vehicle body builder

A lightweight, de-mountable, 250kg capacity electric crane for pickups, dropsides, flatbeds and vans.

Options

- 12v or 24v operation from vehicle battery
- Fitting kit
- Manual stabiliser leg
- Radio remote control
- Extra rope length - 9m/30' up to 250kg
- Corner bracket for mounting direct to headboard
- Additional pillar height
- Battery protection
- Lifting accessory kit



Applications

- Highways
- Construction
- Utilities
- General

ML250 pickup, dropside & flatbed type

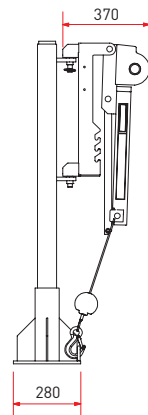
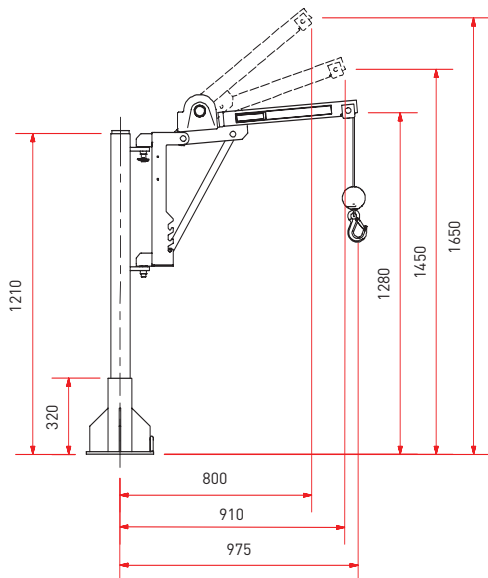

Weights & measurements

Crane section	23kg
Pillar	18kg
Socket	17kg
Corner bracket	5.5kg
Support leg	8kg
Rope length	6m (20') standard
Rating	0.25 tonne metres

ML250 van type

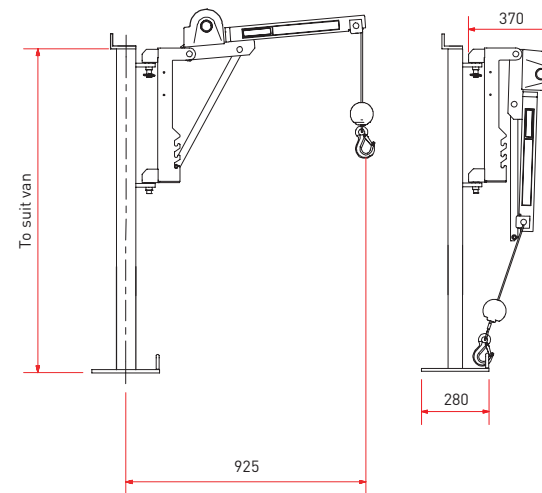

Weights & measurements

Crane section	23kg
Pillar	25kg
Corner bracket	5.5kg
Support leg	8kg
Rope length	6m (20') standard
Rating	0.25 tonne metres

Please note that nearside and offside fittings require a different crane, pillar and fitting kit. It is not always possible to raise the crane boom to its highest position inside a van.



When you need more

Features

- Lifts 500kg in all configurations of boom position
- Remote control
- Easily demountable
- Low crane weight from 44kg (pillar is extra)
- Above or below floor socket mounting for pickups
- Overload protection
- Compact design folds away when not in use
- Manual boom extension with three height settings
- Easily installed at our own premises, on site or by a vehicle body builder

A medium duty electric crane for pickups, dropsides, flatbeds and vans.

Options

- 12v or 24v operation from vehicle battery
- Fitting kit
- Extra rope length up to 12m/40'
- Manual stabiliser leg
- Radio remote control
- Additional pillar height
- Battery protection
- Lifting accessory kit



Applications

- Construction
- Utilities & waste management
- Fire & rescue

ML500 pickup, dropside & flatbed type

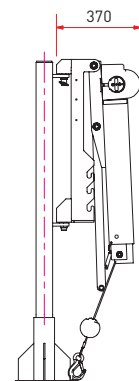
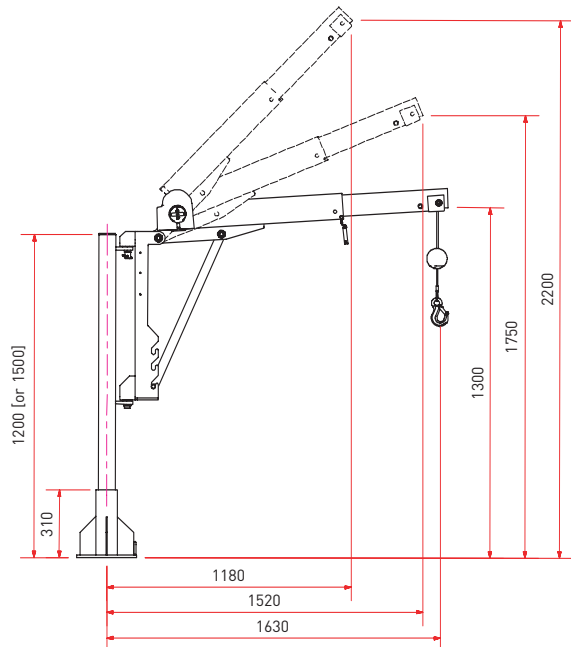

Weights & measurements

Crane section	48kg
Pillar	18 or 22kg
Socket	17kg
Support leg	8kg
Corner bracket	5.5kg
Rope length	6m (20') standard
Rating	0.8 tonne metres

ML500 van type

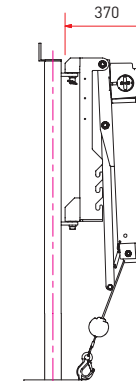
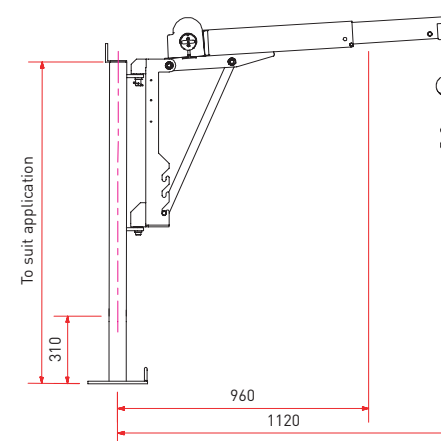

Weights & measurements

Crane section	44kg
Pillar	38kg
Support leg	8kg
Rope length	6m (20') standard
Rating	0.8 tonne metres

Please note that nearside and offside fittings require a different crane, pillar and fitting kit. It is not always possible to raise the crane boom to its highest position inside a van.



For compact power

A compact, 500kg capacity electric crane for pickups, dropsides and flatbeds.

Features

- Lifts 500kg in all configurations of boom position
- Remote control
- Overload protection
- Compact design folds away when not in use
- Low crane weight from approximately 73kg
- Manual boom extension with three height settings
- Easily installed at our own premises, on site or by a vehicle body builder

Options

- 12v or 24v operation from vehicle battery
- Manual or hydraulic stabiliser leg
- Radio remote control
- Fitting kit
- Extra rope length up to 12m/40'
- Additional pillar height
- Battery protection
- Lifting accessory kit



Applications

- Highways
- Construction
- Utilities
- Railways

F500 pickup, dropside & flatbed

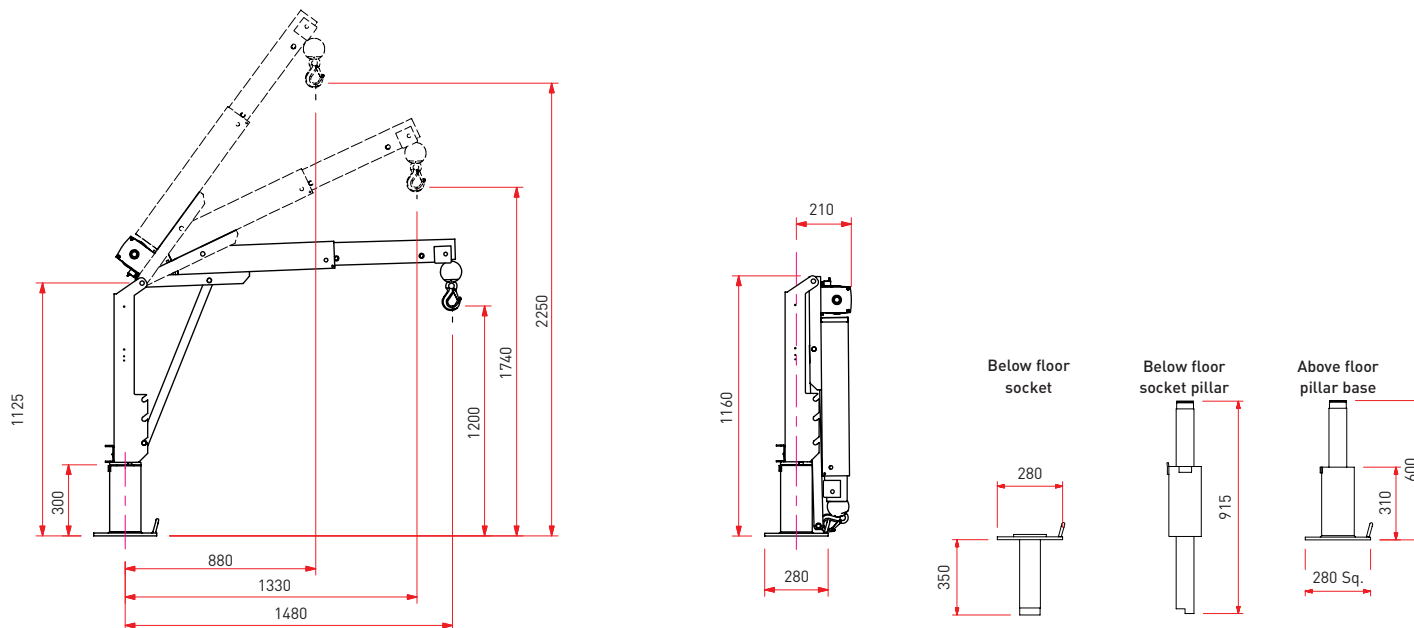

Weights & measurements

Crane section	73kg including pillar base
Support leg	8kg
Rope length	6m (20') standard
Rating	0.75 tonne metres



Controlled precision

The new SwingLift FV500 has hydraulic slew, boom raise, lower and extension for controlled, precise and safe handling. Its 500kg capacity hoist allows vertical below-ground handling making it the ideal solution for local authorities, highways and utilities.

Features

- Suitable for van and chassis applications
- Low crane weight, maximising payload
- Compact design, integral oil tank and motor pump unit maximises load space
- Remote control as standard
- Fully hydraulic operation - boom raise, lower, extension and slew
- Electric winch for below ground applications
- Built in overload protection as standard
- Lifts 500kg in all boom positions

Options

- Mounting frame with integral support legs
- Manual or hydraulic stabiliser legs
- 12 or 24v operation from standard vehicle battery
- Extra rope length up to 40'/12m
- Additional pillar height
- Crane slew stops
- Battery protection
- Lifting accessory kit



Applications

- Highways
- Construction
- Utilities
- Fire & rescue

FV500 pickup, dropside & flatbed type

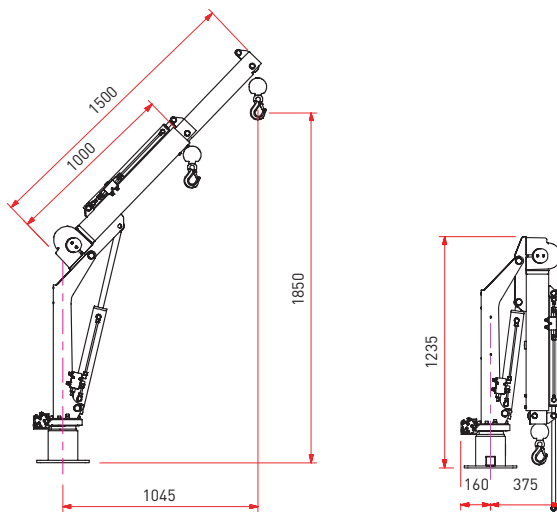

Weights & measurements

Crane	85kg
Support leg	8kg
Rating	0.75 tonne metres

Lifts 500kg in all positions

FV500 van type

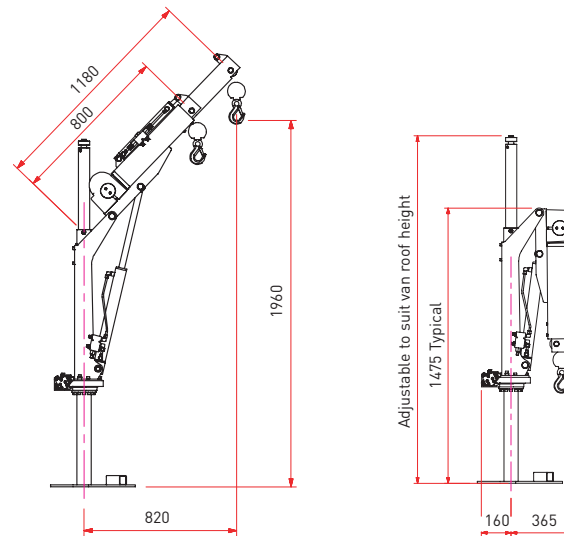

Weights & measurements

Crane	95kg
Support leg	8kg
Rating	0.75 tonne metres

Lifts 500kg in all positions

Fully loaded



The new SwingLift FV1200 is a fully hydraulic 1200kg capacity vehicle mounted crane. With a boom reach of 4.3 metres it is designed for a wide range of load handling applications including service, engineering and deliveries. Its compact design, robust construction and light weight ensure the FV1200 can be installed on a wide range of 3.5t+ commercial vehicles to provide reliable and flexible load handling capabilities.

Features

- Low crane weight, maximising payload
- Compact design, integral oil tank and motor pump unit maximises load space
- Remote control as standard
- Overload protection built in as standard
- Easily installed at our factory or by an approved Penny Hydraulics converter
- A wide range of specifications are available to suit individual requirements

Options

- Mounting frame with integral support legs
- Manual or hydraulic stabiliser legs
- 12 or 24v operation from standard vehicle battery
- Electric or hydraulic winch pack
- Crane slew stops
- Crane attachments available to suit application
- Battery protection
- Lifting accessory kit



Applications

- Highways
- Construction
- Utilities
- Fire & rescue

FV1200

Weights & measurements

Crane	190kg
Above floor subframe	70kg
Manual support leg	12kg
Hydraulic support leg	27kg
Leg beam	11kg
Rating	1.8 tonne metres

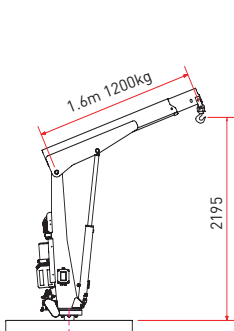

FV1200/1H

Weights & measurements

Crane	195kg
Above floor subframe	70kg
Manual support leg	12kg
Hydraulic support leg	27kg
Leg beam	11kg
Rating	1.8 tonne metres

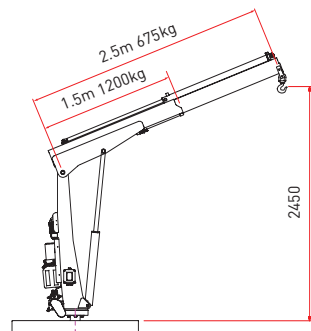

FV1200/2H

Weights & measurements

Crane	235kg
Above floor subframe	70kg
Manual support leg	12kg
Hydraulic support leg	27kg
Leg beam	11kg
Rating	1.8 tonne metres

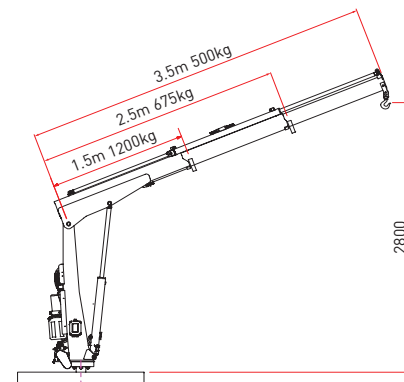

FV1200/1M

Weights & measurements

Crane	270kg
Above floor subframe	70kg
Manual support leg	12kg
Hydraulic support leg	27kg
Leg beam	11kg
Rating	1.8 tonne metres

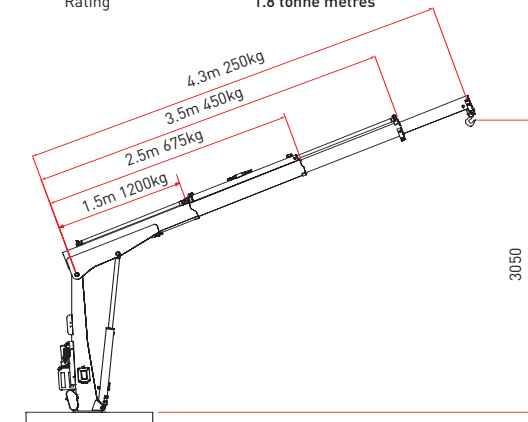



Our big three

Three larger hydraulic cranes combining value for money with unique safety features including load limiting devices, load limit indicator and remote control operation all as standard.

Features

- Low crane weight of 175kg to 263kg
- Remote control
- Compact design – folds down to king post, maximising floor space
- Integrated, fully enclosed oil tank and motor pump unit with easy access for servicing
- Fully controlled hydraulic slewing
- Two extensions with manual or hydraulic operation
- Easily installed at our factory or by an approved Penny Hydraulics converter

Options

- 12 or 24v operation from vehicle battery
- Hydraulic or electric winch
- Manual or hydraulic stabiliser leg
- Additional pillar height
- Crane slew stops
- Crane attachments available to suit application
- Retractable lifting hook
- Battery protection
- Lifting accessory kit



Applications

- Highways
- Construction
- Utilities
- Fire & rescue

V12

Weights & measurements

Crane	184kg
Above floor subframe	70kg
Manual support leg	12kg
Hydraulic support leg	27kg
Leg beam	11kg
Rating	1.26 tonne metres

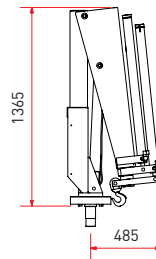
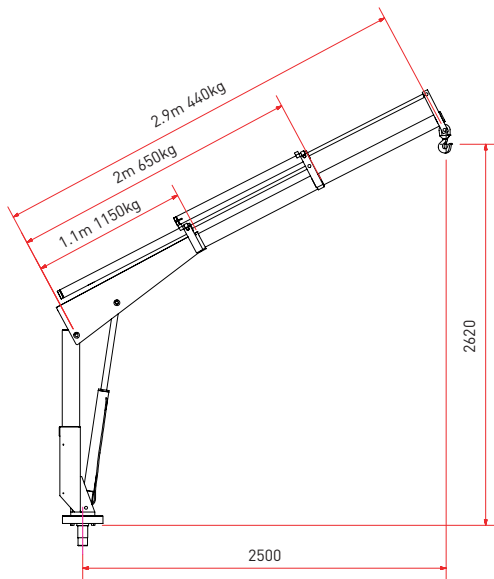

V15

Weights & measurements

Crane	175kg
Above floor subframe	70kg
Manual support leg	12kg
Hydraulic support leg	27kg
Leg beam	11kg
Rating	2.25 tonne metres

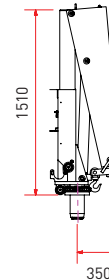
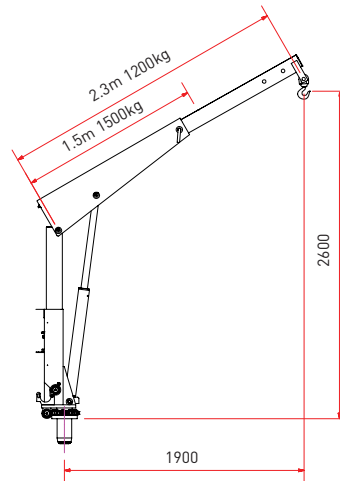

V20

Weights & measurements

Crane	263kg
Above floor subframe	70kg
Manual support leg	12kg
Hydraulic support leg	27kg
Leg beam	11kg
Rating	2.8 tonne metres

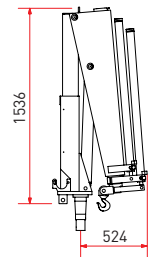
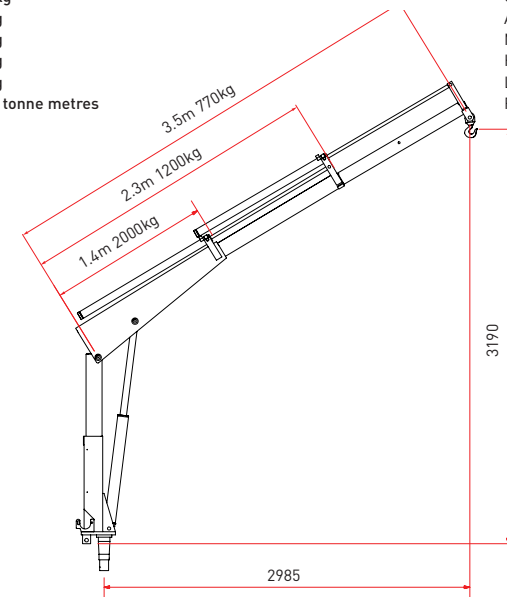



Small enough to fit,
strong enough to lift

The new HS400/V12 tracked crane is a revolution in the small plant market. At just 790mm wide and 1844mm high in its stowed position, the unit is small enough to fit through a standard doorway, but punches well above its size with a lifting capacity of 630kg. Ideal for confined sites and even indoor applications thanks to its battery powered, low vibration chassis and compact, heavy duty crane, the V12 Track Crane quite literally gets to places nothing else can reach.

CHASSIS UNIT FEATURES

- Asincrono electric motor
- n.4 - 12V 200Ah/6 hour duration battery
- Low/high battery life indicator
- 4,75 kW - 3600 g/1' maximum power
- 3600 g/1' rpm
- Electric starting
- 2x10.5 l/1' pumps capacity
- 110 bar pressure
- 1.7 km/h translation speed
- 12.5 litre hydraulic oil tank

V12 CRANE UNIT FEATURES

- 240kg to 630kg maximum working load
- Easily installed and dismantled from the chassis unit
- Remote control
- Low weight of 290kg including subframe and support legs
- Two extensions with hydraulic operation
- Fully controlled 90° hydraulic slewing
- Integrated, fully enclosed oil tank and motor pump unit with easy access for servicing
- Compact design - folds down to king post
- Optional electric winch
- Battery protection
- Lifting accessory kit



Applications

- Plant Hire
- Construction
- Utilities
- Stonemasons
- Arboriculture

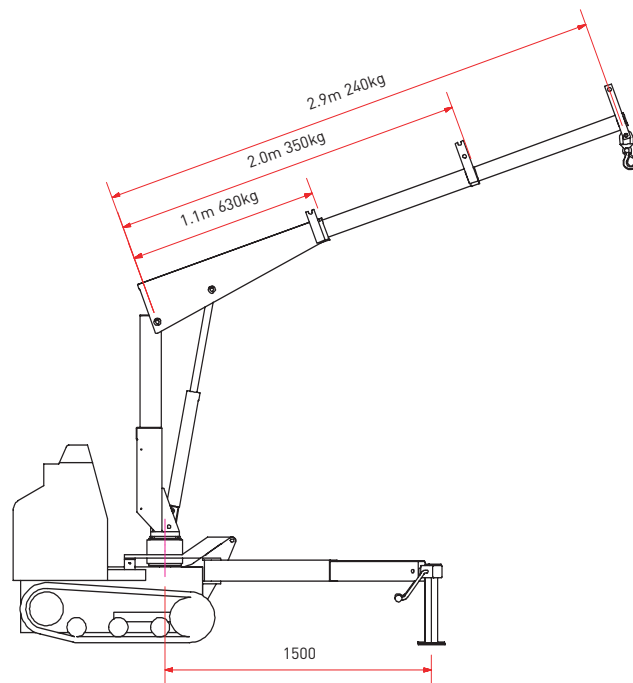

Weights & measurements

Tracked unit	540kg
Crane & subframe	290kg
Rating	0.70 tonne metres

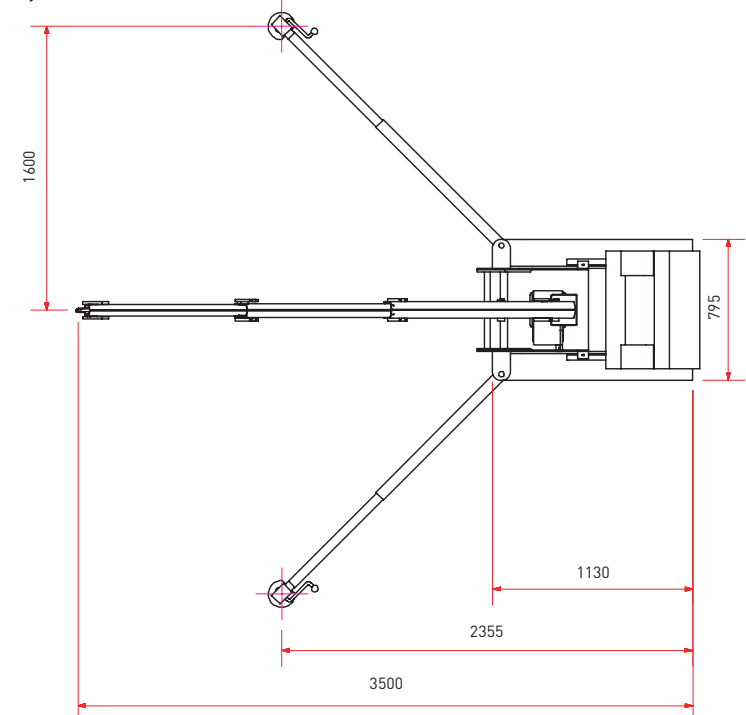
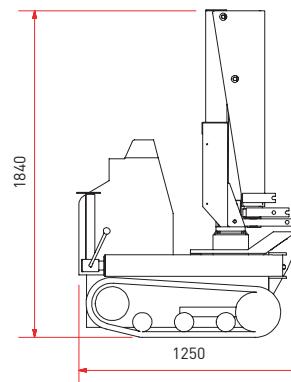



**Go anywhere,
lift anything**

The new TP2000/FV1200 tracked crane is set to transform the crane hire market. Its rugged, tracked chassis can access gravel, sandy, muddy, snowy and uneven terrain whilst its fully hydraulic crane can handle and manoeuvre loads of 1200kg and has a reach of 4.3 metres.

CHASSIS UNIT FEATURES

- GX390 Honda engine
- Electric start
- 1/389cc pistons/displacement
- 13hp/3500 rev/min
- 1.5/2.2 km/h translation speed

FV1200 CRANE UNIT FEATURES

- 1200kg maximum working load
- Low weight of 300kg including subframe
- Two extensions with hydraulic operation
- Integrated, fully enclosed oil tank and motor pump unit with easy access for servicing
- Compact design - folds down to king post
- Optional electric or hydraulic winch pack
- Battery protection
- Lifting accessory kit

Applications

- Plant Hire
- Construction
- Utilities
- Stonemasons
- Arboriculture

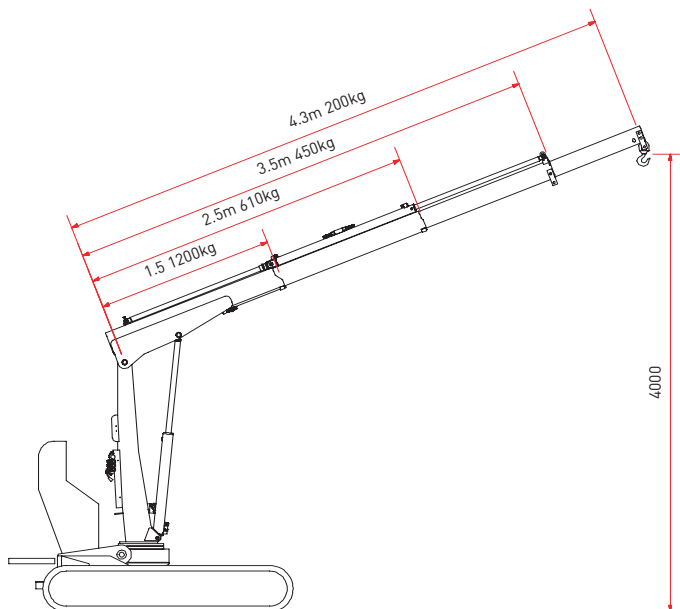

Weights & measurements

Tracked unit	825kg
Crane & subframe	300kg
Rating	1.8 tonne metres

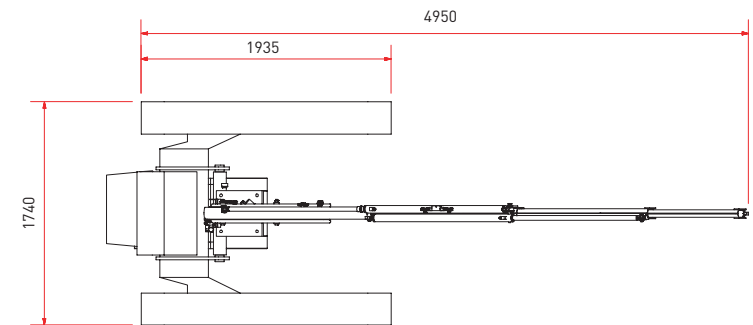
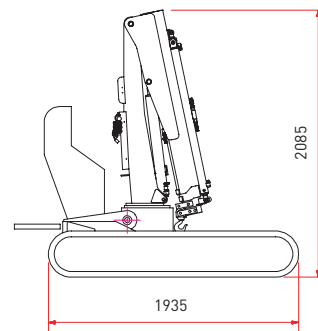

For simple down-hole handling





Features

- Lightweight and portable
- Manufactured from high strength aluminium
- Lifts 500kg in all positions
- Robust construction
- Self contained within a carry bag for ease when working on remote sites
- Helps prevent the risk of injury through manual handling and working over deep wells
- Adjustable from 565-1100mm

Light weight, robust construction and ease of use combine to provide users with a versatile and effective load handling tool.

Options

- 12 or 24v hoist with built in overload protection
- Boom extension with up to 1900mm reach
- Extra rope length - up to 50'/16m
- Overload device
- Lifting accessory kit

Applications

- Highways
- Construction
- Utilities
- Local authorities
- Tyre industry

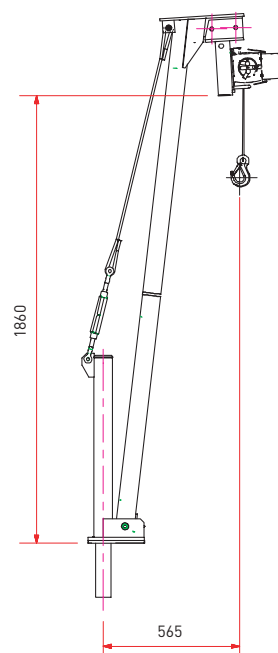
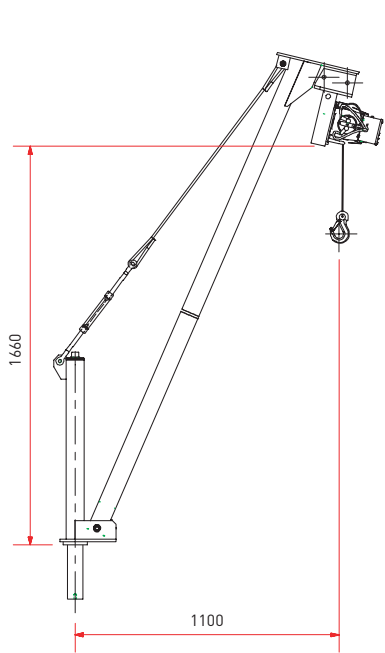

Weights & measurements

Winch	22kg
Base	12kg
Upper crane section	4.2kg
Turnbuckle	2.3kg
Optional	
Boom & winch	13kg

Optional version with extended boom

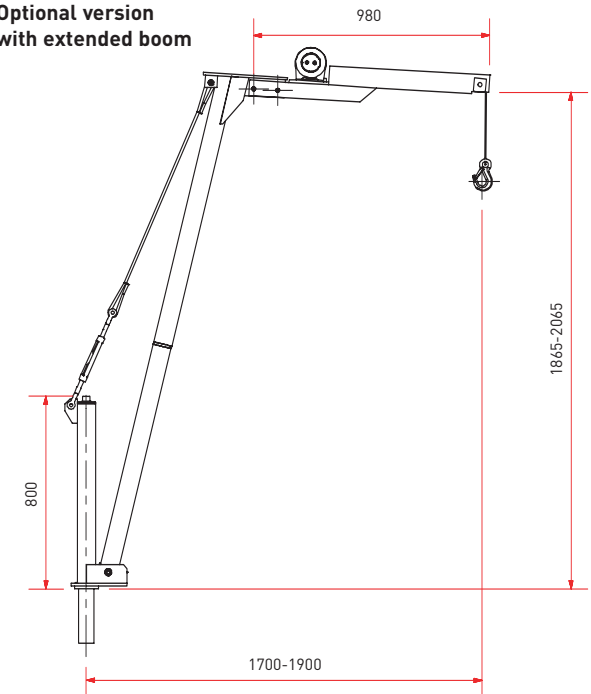

Light on weight, heavy on features



A lightweight and compact lifting platform for loading pickups, Luton and box vans.

Features

- Low self weight maximises payload
- Standard 500kg MWL
- Specifically designed to suit pickup and dropside vehicles
- No under-slung columns, ropes or chains
- Cantilever action means standard tow bars can be fitted
- A wide range of platform materials are available including steel, mesh and aluminium
- A wide range of platform sizes tailored to suit your requirements, including folding platforms



Options

- Radio remote control
- Bespoke platform sizes
- Upgrade up to 550kg MWL
- Folding or drop-in guard frames
- Manual back-up hand pump
- Battery protection

Applications

- Highways
- Construction
- Utilities
- Tyre industry

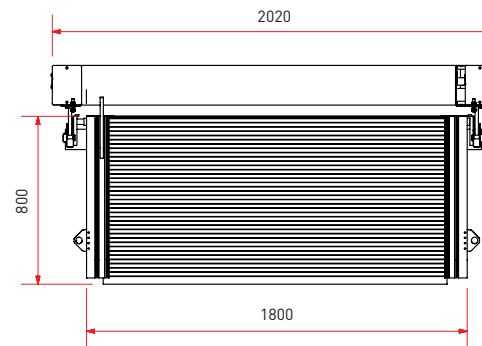
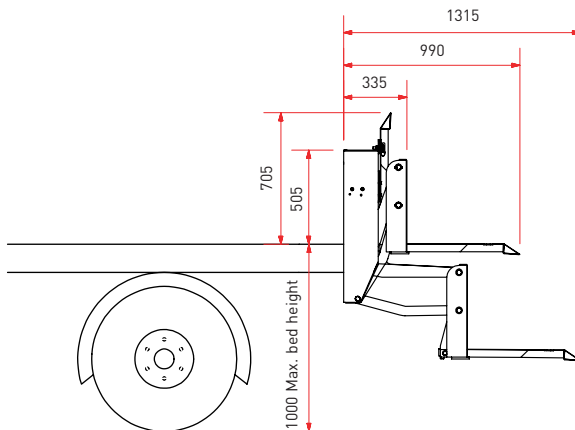

Platform range

- | | |
|--|-------|
| • 750mm steel platform | 150kg |
| • 800mm galvanised steel mesh platform + 200mm toe | 140kg |
| • 600mm aluminium platform + 200mm toe (illustrated) | 138kg |
| • 800mm aluminium platform + 200mm toe | 143kg |
| • 800mm aluminium platform (including 200mm fold) + 200mm toe | 145kg |
| • 1000mm aluminium platform (including 200mm fold) + 200mm toe | 153kg |



Rear loading redefined

A lightweight and compact lifting platform for loading 4x4 pickups and Land Rovers.

Features

- Excellent off-road ground clearance
- Specifically designed to suit pickup and dropside vehicles
- No under-slung columns, ropes or chains
- Cantilever action means standard tow bars can be fitted
- Low self-weight maximises payload
- Standard 500kg MWL
- A wide range of platform materials are available including steel, mesh and aluminium
- A wide range of platform sizes tailored to suit your requirements, including folding platforms

Options

- Radio remote control
- Bespoke platform sizes
- Folding or drop-in guard frames
- Manual back-up hand pump
- Battery protection

Applications

- Highways
- Construction
- Utilities
- Railways
- Tyre industry

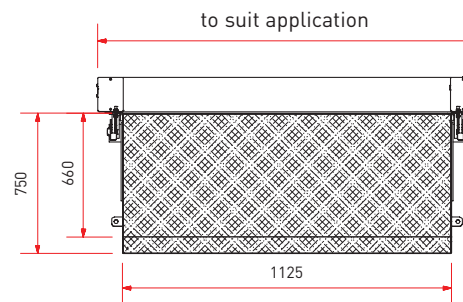
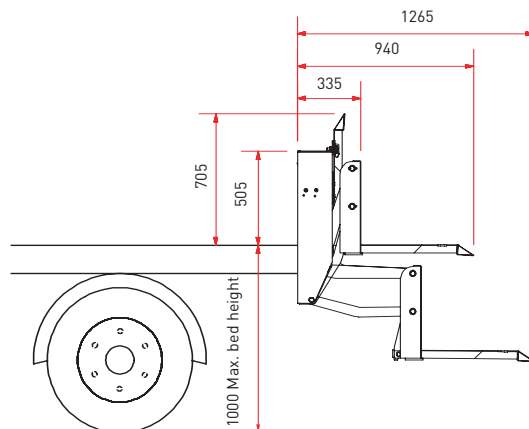

Platform range

- | | |
|--|-------|
| • 750mm steel platform | 145kg |
| • 800mm galvanised steel mesh platform | 138kg |
| • 600mm aluminium platform + 200mm toe | 135kg |



Roadside assistance

Designed for 3.5 to 17 tonne vehicles, SideLift 250 enables deliveries to be made directly onto the kerbside, dramatically reducing the space required to park and enabling more even distribution of the load, thereby reducing route planning time and risks of axle overload.

Features

- Hydraulically powered for a smooth controlled operation
- Easy installation, no welding required
- 12v or 24v versions available
- Minimal reduction in vehicle payload
- Handles loads up to 250kg
- Remote and static controls
- In cab isolator and warning buzzer
- Hydraulic overload protection

Options

- Radio remote control
- Off-set platforms
- Battery protection



Applications

- Highways
- Construction
- Utilities
- Local authorities
- Tyre industry

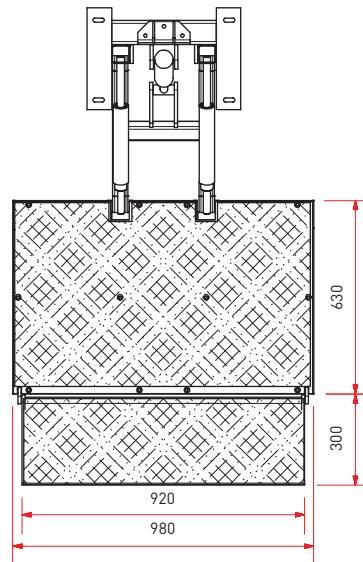
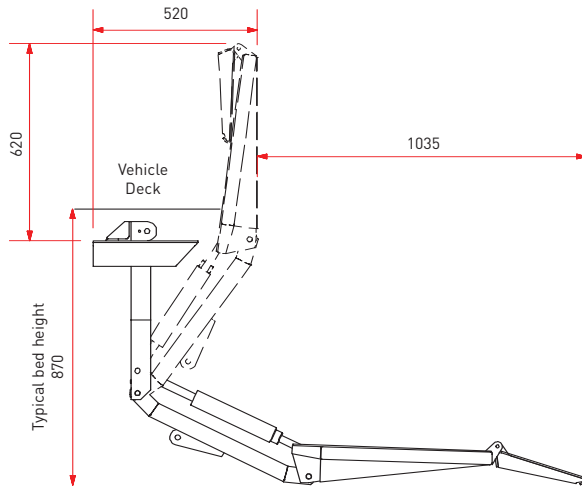

Weights & measurements
Total self weight 95kg



One small step...

Features

- External mounting allows unhindered access and means that internal load space can be utilised to its maximum
- Hydraulically powered for a smooth controlled operation
- Easy installation, no welding required
- 12v or 24v versions available
- Standard 250kg MWL
- Minimal reduction in vehicle payload
- Remote and static controls
- In-cab isolator and warning buzzer
- Hydraulic overload protection
- Anti-roll-off toes and bridging flaps on multifold platforms where applicable

A unique lifting platform that replaces the rear step for loading most types of van.

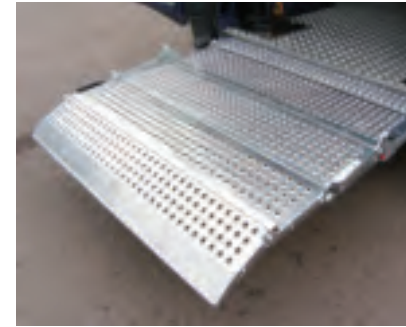

Options

- Bespoke platform sizes
- Radio remote control
- Towing bracket
- MWL upgrade
- Side rails
- Reversing sensors
- Battery protection

Applications

- Highways
- Construction
- Utilities
- Fire & rescue
- Healthcare
- Plumbers' & builders' merchants

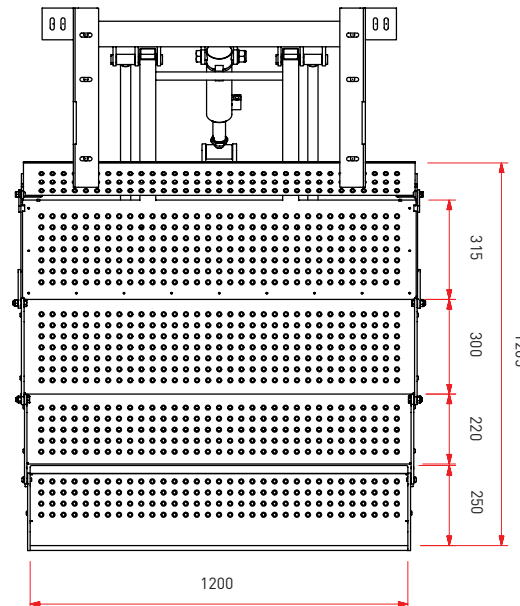
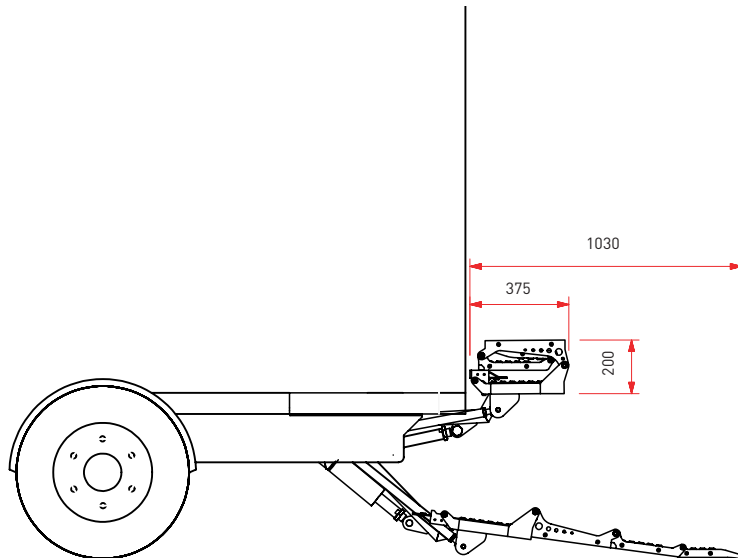

Platform range

- 825mm x 315mm step only 80kg
- 825mm x 615mm single fold 95kg
- 1200mm multifold (as illustrated) 105kg

To the rescue



A lightweight and compact lifting platform for loading vans via either the side or rear doors.

Features

- Side or rear door application
- Maintains unhindered access
- Standard 250kg MWL
- Hydraulically powered for a smooth action
- 12v or 24v operation from vehicle battery
- Remote control
- Overload protection
- Compact design maximising floor space
- Low weight of approximately 100kg for minimal impact on vehicle payload
- Easily installed at our own premises, on site or by a vehicle body builder

Options

- Bespoke platform sizes
- Roll-on tyre carrier with re-grooving clamp
- Radio remote control
- Upgrade to 350kg MWL
- Battery protection

Applications

- Construction
- Utilities
- Fire & rescue

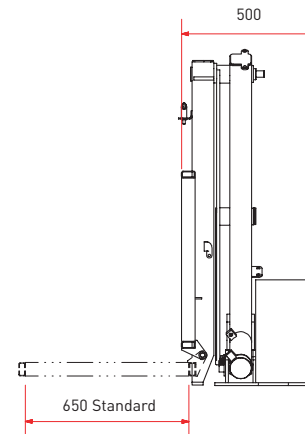
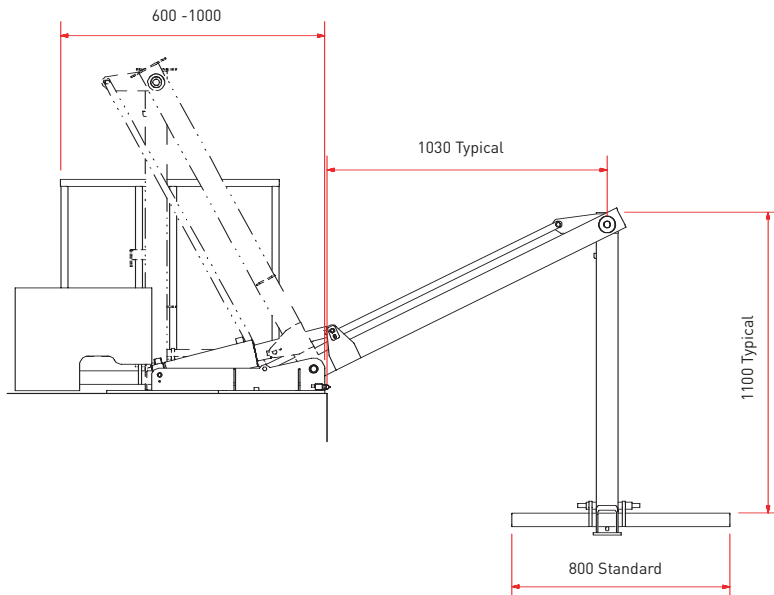

Weights & measurements

Total self weight 100kg

Both side and rear door models have the same standard platform size of 650 x 800mm - this can be increased when fitting to the rear (vehicle width permitting)

First class delivery



Features

- Automatic roll-stops with manual override
- Rear door application
- Internal mounting prevents damage due to sleeping policemen & unauthorised use
- Maintains unhindered access
- Standard 250kg MWL
- Hydraulically powered for a smooth action
- 12v operation from vehicle battery
- Manual back-up facility
- Fixed & remote controls
- Overload protection
- Compact design maximising floor space
- Low self-weight for minimal impact on vehicle payload
- Durable - ideal for multi-task operations in urban & rural environments

A lightweight and compact lifting platform for loading containerised goods via the rear doors.



Options

- Bespoke platform sizes
- Radio remote control
- MWL upgrade
- 12v or 24v operation
- Battery protection

Applications

- Mail delivery
- Healthcare
- General

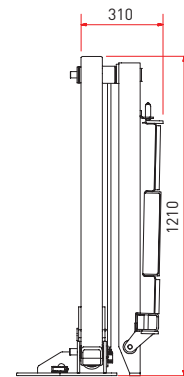
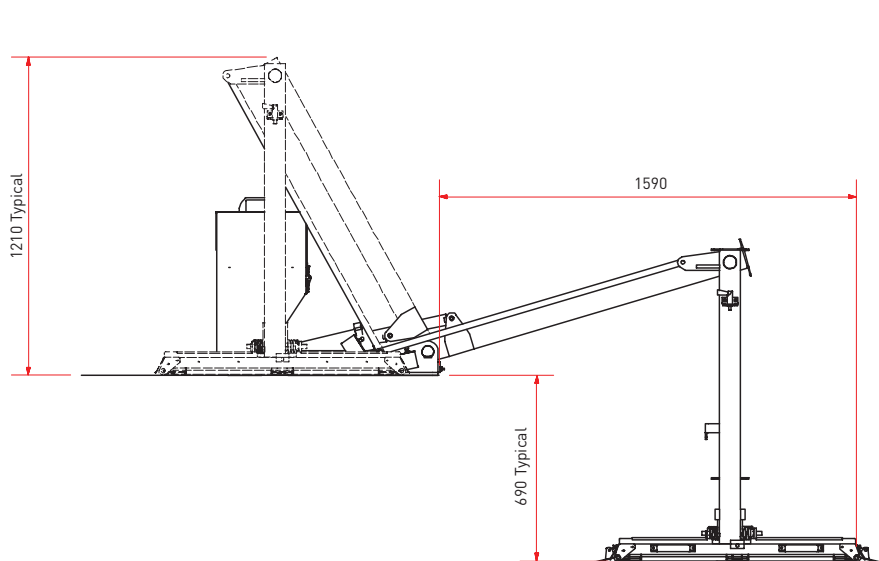

Weights & measurements

Total self weight 160kg

Platform dimensions (bespoke sizes available)

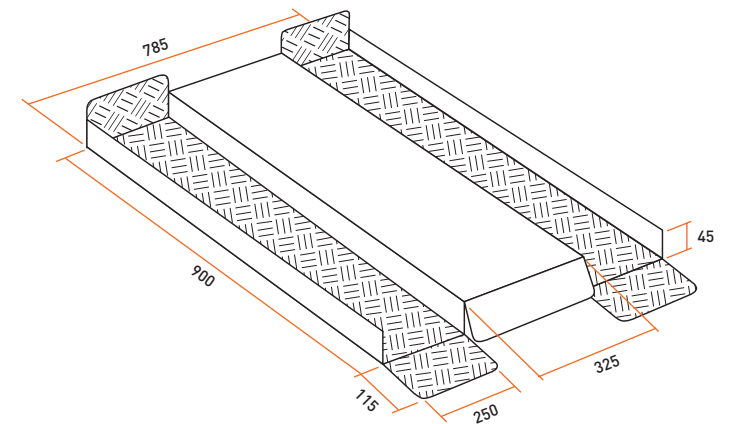

Great handling



Single Wheel Lift solves lifting and re-treading problems associated with large vehicle tyres.

It has a maximum working load of 125kg with an optional MWL upgrade available.

The roll-on/roll-off platform and easy to operate locking device create the ideal tool for re-grooving tyres, outside the vehicle, or inside, away from the elements.

Features

- Maintains unhindered access
- Hydraulically powered for a smooth controlled operation
- Side and rear door applications
- Minimal impact on vehicle payload
- Remote and static controls
- Roll-on/roll-off platform
- Hydraulic overload protection
- Standard 125kg MWL

Options

- Radio remote control
- Bespoke platform size
- Upgrade to 350kg MWL
- Re-grooving clamp
- Battery protection

Applications

- Highways
- Construction
- Utilities
- Railways
- Tyre industry

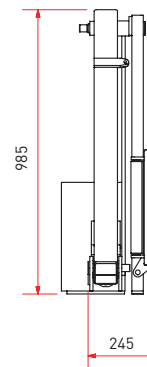
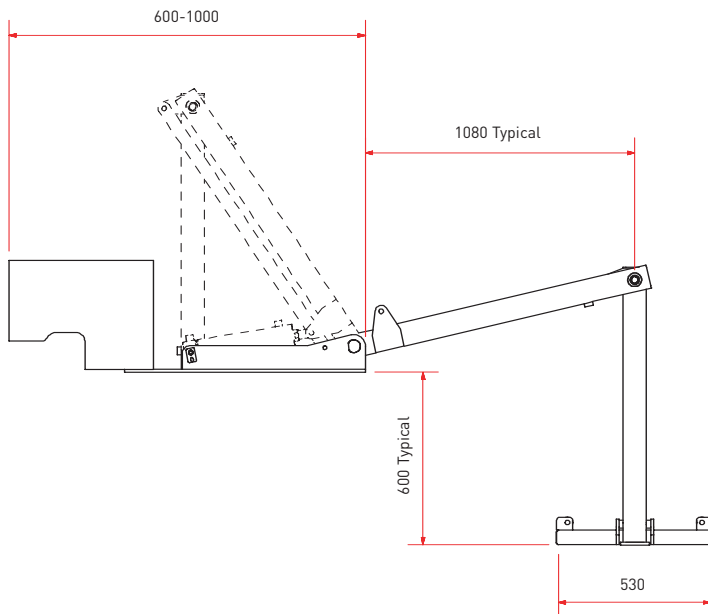

Weights & measurements

Total self weight 60-100kg



A weight off crews' shoulders

The new GridLifts are designed for installation on highways maintenance vehicles such as gully tankers and jetters, for lifting heavy covers out of the way and to provide clear access for safe, efficient cleaning and maintenance. Crews can clear more gullies in the same period with greater safety, each operation taking only around two minutes.

Features

- Choice of 250kg and 300kg lifting capacity makes light work of seized covers which have been impossible to free by conventional equipment
- Replaces alternative cover handling equipment such as electric winches which can be difficult to use and even unsafe
- Hydraulic rams extend and retract the lifter to raise and lower the gully lid
- Smooth, precise and accurate movements for the best possible combination of performance and safety

- Designed to pivot so that the cover can be moved aside for easy access and cleaning of the gully
- Separate frame locks into place on the end of the vertical arm and attaches securely to the gully cover by simple twist clips that can accommodate castings with different profiles
- Remote control key pad allows maintenance crews to stand safely away from any moving parts during lifting and lowering
- Two independent locking pins secure the device safely in the retracted position when the vehicle is moving to comply with vehicle safety regulations



Applications

- Utilities & waste management
- Highways
- Local authorities

GridLift GL300

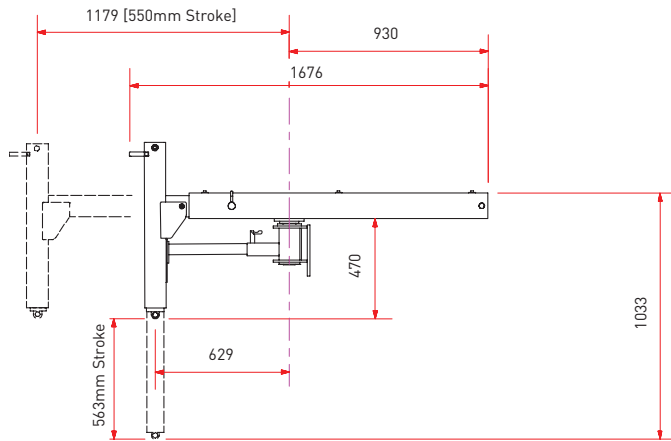

Weights & measurements

Total self weight 140kg

GridLift GL250KJ

Knuckle joint model

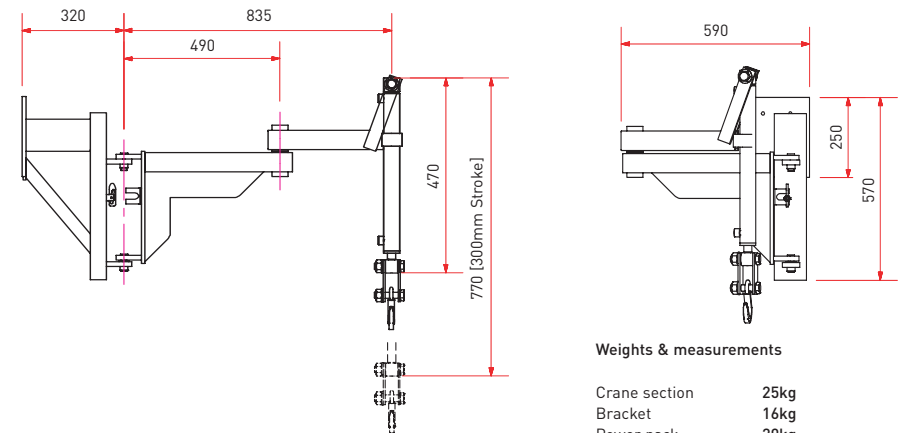

Weights & measurements

Crane section	25kg
Bracket	16kg
Power pack	20kg

Keeping you
on the road



Heavy duty 120t mobile

Trailer dimensions

Overall length	3050mm
Overall width	1880mm
Weight	1700kg

Aperture dimensions

Bed width	900mm
Aperture width	1080mm
Aperture height to spider	870mm
Spider plate diameter	630mm

Standard equipment (120t mobile)

- 230v power supply
- Hold to run handle allows operator to stand in a safe position
- Milled spider plate with British Standard T Slots
- Set of 12 press legs (6 long, 6 short)
- Twin axle trailer
- Heavy duty, lockable tow hitch
- 12 months **ON SITE** warranty

Optional equipment (120t mobile)

- Dual voltage input 230v/110v with 110v and 240v power outputs
- Heavy duty on-board diesel generator
- Miniloader crane
- Tool box
- Comprehensive range of tooling

Designed and built in the UK to the latest industry standard the Penny Hydraulics Tyre Press range provides reliable, robust and efficient service to the solid tyre industry. 120 tonne presses are available either van mounted, trailer mounted or for static applications. A larger 150 tonne press is also available.

Standard 120t mobile

Trailer dimensions

Overall length	3000mm
Overall width	1680mm
Weight	1450kg

Aperture dimensions

Bed width	600mm
Aperture width	890mm
Aperture height to spider	870mm
Spider plate diameter	630mm



Static 120t medium

Aperture dimensions

Bed width	900mm
Aperture width	1080mm
Aperture height to spider	870mm
Spider plate diameter	630mm

Standard equipment

- Downstroking ram
- Low bed height
- Milled spider plate
- 3 phase power pack

Static 150t large

Aperture dimensions

Bed width	1050mm
Aperture width	1200mm
Aperture height to spider	1000mm
Spider plate diameter	915mm

Standard equipment

- Upstroking ram
- Milled spider plate
- 3 phase power pack

Optional equipment

- Steps or access platforms made to order
- Bespoke lifting equipment
- Comprehensive range of tooling
- Single phase power
- Corporate paint colour

Nationwide service contracts are available to ensure safe and reliable operation

Comprehensive
range of
TyrePress tooling
available

Contract lease
Tyre presses from
less than £80 a week
Call 01246 811475
for details

Penny Hydraulics offer a wide range of electric and hydraulic winches from top manufacturers including Warn, Superwinch and Rule for all types of commercial vehicle and industrial applications. From small, robust trailer winches such as the Rule V14 and V60 range through to bumper mounted winches like the Warn XD9000i and X8000i up to serious recovery winches such as the Superwinch Huskey. Whether you require a winch for unloading your

boat or car trailer, a commercial application such as utility companies or self recovery, Penny Hydraulics have the capacity to meet your requirements. We have an excellent stock of winches and parts most of which are available on next day delivery. A fitting service is available at our factory which also offers a repair and test facility. We supply, service, inspect and issue test certificates for a range of vehicle mounted winches and spectacle lifts.



- Hydraulic winches • Electric winches • Mechanical drive winches
- Air powered winches • Hand operated winches



Features

- Nationwide coverage
- Service, repairs & product support
- Wide product range with large stocks
- Prompt delivery
- Competitive prices
- 12-24 volts DC/110-240/415 volts AC

The ingenious portable WinchPack is a self-contained electric winch and rope assembly that can be used on any commercial vehicle with a towbar to provide additional load handling capabilities. It simply mounts to a standard towbar within seconds when required to offer temporary winching, for example to assist trailer loading or to raise items from underground.

Features

- Available in two versions - V14 (522kg/1400lb line pull) & V60 (2238kg/6000lb line pull)
- 12 or 24 volt power
- Rope lengths up to 27m/90ft
- Wander lead remote control
- Free spool device
- Low weight of 20kg for ease of handling





LoadLift fitted to 7.5t rigid for handling waste oil barrels.



Easyloader TailLift and folding guard frames developed for Severn Trent Water.



LoadLift fitted to a Ford Ranger, specially developed for Shropshire Fire Brigade.



LoadLift specially developed to fit inside a Land Rover Freelander.



LoadLift specially developed for Telent and Siemens to handle cable drums.

LoadLift with anti roll-off toes.



Side mounted LoadLift for transporting cryogenic gas cylinders.

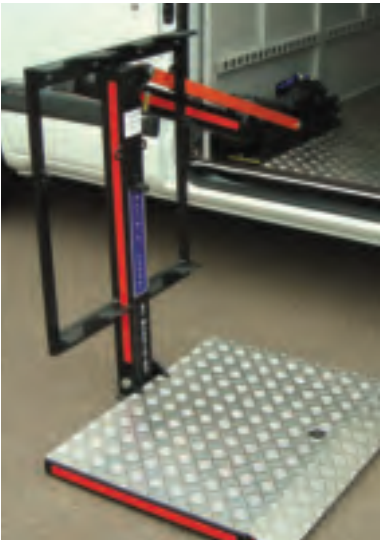

SideLift fitted to a 12t rigid bodied truck for pavement deliveries in busy towns and cities.

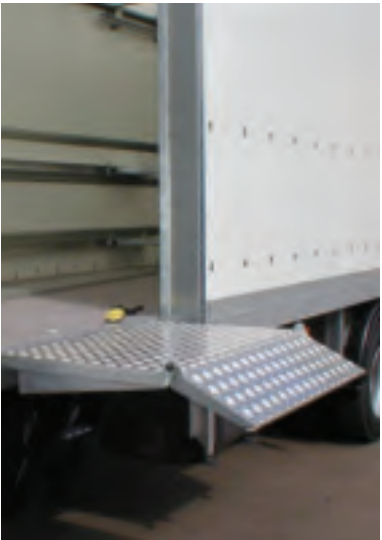

SideLift fitted to Kingsway Tyres VW Crafter - ideally suited to loading tyres away from the risks associated with working at the rear of the vehicle on busy roads.



LoadLift (rear door application) showing how Penny Hydraulics can adapt and build bespoke units to obtain the best possible result for the customer.





SwingLift ML250 built for the MoD.



Gas bottle crane originally supplied to Calor Gas to increase safety and efficiency of small drop deliveries.



FV1200 showing how ideally suited this strong yet compact crane is for loading heavy items onto a 3.5t vehicle. With a 1.2 tonne capacity it will easily load and unload 1 tonne bags of sand.



Corner crane, ideal for loading plant or chemical drums where space is at a premium.



4x4 pickup complete with SwingLift F500 crane and SLF7 floor frame.

SwingLift two metre knuckle joint crane fitted to a "hot box" vehicle used for lifting and lowering heavy propane cylinders.



V Range crane internally mounted within 18t truck for delivering self-erection garages.



SwingLift F500 fitted to a Penny Hydraulics gas bottle recovery trailer.



SwingLift special fitted to a general purpose plant trailer.



SwingLift special developed for the MoD to service the motors on target ranges.





Hydraulic support leg with optional interlocks and warning lamps.



Penny Hydraulics vacuum kerb lifter with built-in reserve tank for increased safety.



Short handled kerb grab.



Penny Hydraulics dumpy bag lifter.



Penny Hydraulics WinchPack complete with remote control, integral solenoids and free spool.

Gas bottle recovery trailer used by BOC as a fast response trailer to deal with spills, hazards and discarded gas cylinders throughout the UK.



LoadLift (side door application) showing how the power pack can be remotely mounted under the passenger seat creating a spark-free environment and even greater load space.



500kg Davit Crane specially developed with the MoD for lifting heavy target motors and gearboxes when routine maintenance is required.

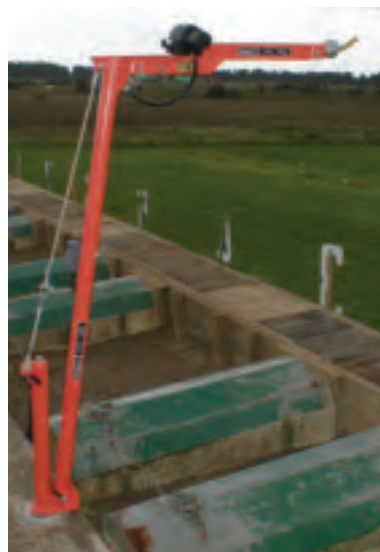

British Museum crane for fitting the glass panels into the domed roof.



Hydraulic TV screen with 7.5t lift and 360° slew.





On another level

A robust and versatile platform lift to raise and lower goods safely and efficiently between floors. Each lift is tailored to customers' own specifications - please call our Helpline on 01246 811475 for more information.

Features

- Rugged, reliable & proven construction
- Hydraulic overload protection
- Hold to run controls
- No lift pit required
- Can operate outside
- Compact design
- Standard 240 volt 20 amp power requirement

Options

- Free-standing fabricated shaft
- Inter-locking gate system
- Railings or guard panels to suit location
- Loading ramp
- Bespoke platform
- Dual push button control stations
- 3-phase motor



Applications

- Tyre industry
- Factories
- Warehousing
- Retail



Each MezzLift is bespoke and built to suit individual customer requirements.

For further information please contact our customer Helpline on 01246 811475

Service

Current legislation requires that each item of lifting equipment be thoroughly examined at least once in every 12 month period by a competent person. Our service contract will ensure continued, safe, reliable use of the equipment and full compliance with current legislation. Key benefits of a Penny Hydraulics service contract include...

- Combined maintenance and statutory inspection saves time and money
- Nationwide coverage
- Statutory inspections completed
- OEM spares available ex-stock
- High first time fix rate
- Reduced vehicle downtime

Training

The latest health & safety legislation requires that all employers ensure all people using or supervising the use of work equipment have received adequate training in method, risk and precautions. Penny Hydraulics offer nationwide training by qualified instructors for their comprehensive range of lifting equipment. Training includes practical and theoretical input from the delegates with a certificate of competence issued on successful completion of the course

On-site fitting

As well as a fleet of service engineers to service and maintain your lifting equipment, Penny Hydraulics also offer a national on-site fitting service. Not only does this ensure the correct installation of your crane or lift, it minimises your vehicle movement and downtime.

Thank you for taking the time to look through this brochure... we hope it has been of interest and that you have found a product that will meet your needs.

As well as offering unbeatable features and superb value for money, every one of our products also delivers...

- **Increased productivity**
- **Increased efficiency**
- **Increased flexibility of labour**
- **Reduced injury claims**
- **Reduced damage to equipment and property**
- **Reduced vehicle down time**
- **Full compliance with manual handling regulations and current HSE guidelines**



Remember, the strength, reliability and low maintenance of all our cranes and platform lifts means reduced down time and cost-effective operation throughout their life.

If your business needs a lift, your business needs a Penny Hydraulics lift.

30
years

Delivering lifting solutions

“ Penny Hydraulics couldn't have been more helpful. They listened to what we had to say and came up with a solution. ”

Pete Bromley,
Sutton Harbour Company

“ Penny Hydraulics is a very slick company - they provided exactly what we needed and most crucially slotted into a tight timeframe which suited our requirements. ”

George Buchanan,
Hodsock Priory

“ We wanted a supplier with the tyre handling products and nationwide support to match our own operations. Nobody has the combination of products and support offered by Penny Hydraulics. ”

Tim Richards,
Group Vehicle & Equipment
Manager, ATS Euromaster



The present factory under construction

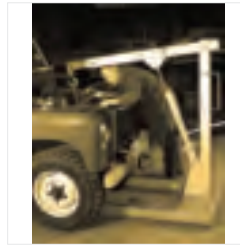

An original Tirfor crane

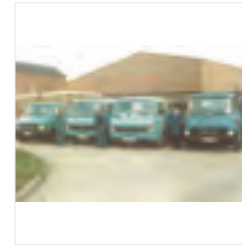

The lorry fleet for collecting hydraulic repairs

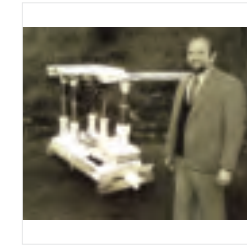

John Marples with the first chock for Germany in 1983

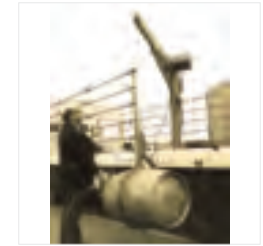

John Penny Snr with the Bass brewery crane

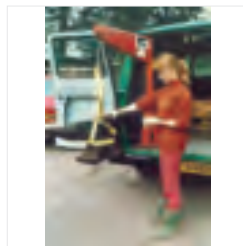

The first SwingLifts with their distinctive booms

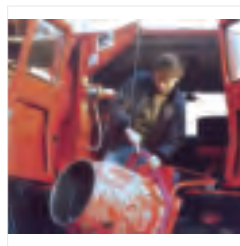

CellarLift number one in the Blue Peter, Derby

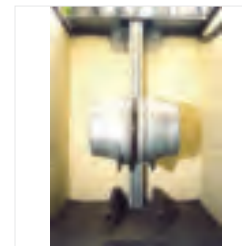

Early photo shoot at the Shuttleworth Collection

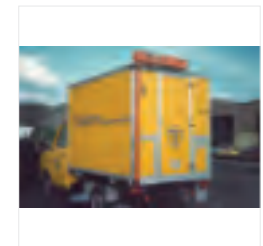

The start of a long relationship with BT

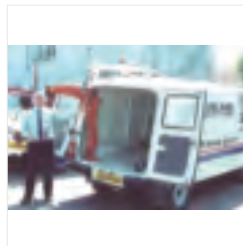

Dick Medhurst with our first export, to Guernsey

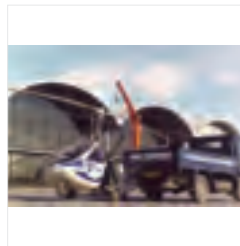

The company is really starting to take off

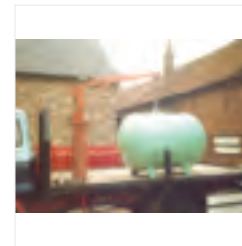

The first of many special SwingLift cranes



Our current service vehicles



The latest in 3D modelling and CAD capabilities



The innovative 4x4 pickup Easyloader



Now an established member of major events and many trade organisations



The new FV500...

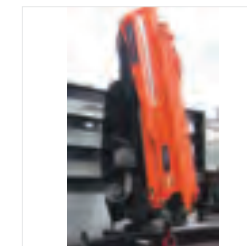

...FV1200...



...and York LoadLift

“ Penny Hydraulics worked closely with Shropshire Fire & Rescue Service to adapt their existing LoadLift to create a new equipment module lift system. From the start of the project they were open to the diverse requirements of the vehicle and equipment and this created a good working partnership in the early development stage. ”

Andy Perry, Assistant Divisional Officer
Shropshire Fire & Rescue Service

“ ATS Euromaster is very health and safety conscious and we always specify equipment to help and protect employees in the work place. Mechanical lifting is the way to go. The best type of vehicle for the job is an enclosed van and the Penny Hydraulics LoadLift SWL is the ideal product for that type of vehicle. ”

Tim Richards,
Group Vehicle & Equipment Manager,
ATS Euromaster

FREE
no obligation
demos
Call 01246 811475
to arrange yours



PennyHydraulics



Penny Hydraulics Ltd | Station Road | Clowne | Chesterfield | Derbyshire | S43 4AB | United Kingdom
Telephone +44 (0) 1246 811475 | Facsimile +44 (0) 1246 810403 | Email sales@pennyhydraulics.com
www.pennyhydraulics.com