



RELIABLE SAFE ACCESS

# Kee Pallet Gate Operation and Maintenance Manual







## PALLET SAFETY GATES

KEE PALLET GATES are a range of pallet/mezzanine gates designed specifically to provide permanent hazard protection when moving goods between different working levels.

KEE PALLET GATES can provide permanent protection for any openings where material/pallet access is required. The gates have been specifically designed to provide a “retro-fit” solution to existing guardrails where opening protection is required.



## APPLICATION

The KEE PALLET GATE range has been designed to be fully adjustable in width and can accommodate openings up to 1.8m (6').

Connecting the KEE PALLET GATE to the supporting structure is simple using KEE KLAMP fittings which are directly fixed to the existing guardrail or mechanically/chemical fixed to the masonry or concrete structure

## DURABILITY

KEE PALLET GATES are available in a range of high quality finishes.

Galvanised: components are supplied with a galvanised finish to BS EN ISO 1461 and ASTM A53: Hot Dip Galvanised Coatings Specification and Testing Methods, giving an average coating of between 55-100 microns.



## COMPONENT BASED SYSTEMS

All products consist of high quality tubing and cast clamps that seamlessly compliment the Company’s safety portfolio. KEE PALLET GATE is easily installed to existing and new structures using all variants of the KEE KLAMP range to provide a safe compliant solution.



# Kee Pallet Gate System Overview



## TESTING & CERTIFICATION

Tested in accordance with the following (See Specification Section for full details) :-

EN ISO 14122 Part 3 & Part 4

OSHA

ANSI

Ontario Building Code, NBC and British Columbia Building Code

Canadian Standards Association

Canada Occupational Health and Safety

**LIFE CYCLE TESTING** - BS 6375-2:2009 Clause 6.5 - Opening and closing of the hinge mechanism.

**SALT SPRAY TESTING** - ASTM B117 - 11 - 55 over 200 hours to assess performance of coating to resist corrosion.

## OFFICIAL DOCUMENTATION

All Systems comply with the following:-

Work at Height Regulations.

European Union Directives together with requirements of CDM Regulations. USA & Canada.

## AESTHETICS

The smooth lines of the standard galvanised finish can be further enhanced by the application of powder coating to EN 13438.

USA-AAMA 2603-2605.

## SYSTEMS DISTRIBUTORS

KEE PALLET GATE is available as a supply and installation service or component supply only. Products are available from one of Kee Safety's licensed distributors.



# Kee Pallet Gate Compliance

## PRODUCT SPECIFICATION – EUROPEAN – USA - CANADIAN

**FEATURES:-** Manually operated balanced safety pallet gate.

### GENERAL

KEE PALLET GATE requires physical fixing to the buildings' structure.

### MATERIALS

#### EUROPEAN

Steel tubing to EN 10255.

33.7mm diameter tube x 3.2mm wall thickness.

48.3mm diameter tube x 3.2mm wall thickness

All steel components galvanised to BS EN ISO 1461.

All fixings are hot dipped galvanised to BS EN ISO 1461.

All cast clamps have THREDKOAT applied to all tapped holes. All grub screws are carbon steel and have KEE KOAT protection applied to ensure minimal maintenance.

Where tubing is cut on site zinc rich paint is applied to the cut end of the tube.

Powder Coating to EN 13438.

#### USA & CANADA

All steel components galvanised steel to ASTM A53.

All fixings are hot dipped galvanised to ASTM A53.

Powder Coating to USA-AAMA 2603-2605.

#### LAYOUT EUROPE & CANADA

Recommended installed height of a KEE PALLET GATE is 1.1m in Europe and Canada depending on the structure it is fixed to and National Regulations . Standard pallet gate width 1.4m. Internal gap between top and bottom guardrail 466mm. Guardrail centre to centre 500mm

#### LAYOUT USA

Recommended installed height of KEE PALLET GATE is 42" in the USA depending on the structure it is fixed to and National Regulations.

Standard Type A, B and C gate width is 1.6m, Type D gate features 1.8m opening. Internal gap between top and bottom guardrails is 18.35".

## TESTING

EN ISO 14122 Part 3 & Part 4

OSHA – 200 lb applied to the top rail of the gate and 150 lb on the mid-rail of the gate

ANSI – The gate must comply with the same loading requirements as the structure to which it is attached.

IBC – designed to resist linear load of 50 lb/ft

Ontario Building Code, NBC and British Columbia Building Code – “Handrails and any building element that could be used as handrail shall be designed and attached in such a manner to resist, (a) a concentrated load at any point of not less than 0.9 kN (202 lb) and a uniformly distributed load of 0.7 kN/m (48 lb/ft).

OBC and NBC state – “all other guards” – 0.75 kN/m (52 lb/ft) or concentrated load of 1.0 kN (224 lb) applied at any point on top of the guard

Evenly distributed vertical load on top of the guard – 1.5 kN/m (103 lb/ft)

Canadian Standards Association – 0.9 kN (202 lb), 0.7 kN/m (48 lb/ft) – states

“Guard – a protective barrier around an opening in a floor or at the open side of stairs, a landing, balcony, mezzanine, gallery, raised walkway or other location; used to prevent accidental falls from one level to another; such a barrier may or may not have openings through it.”

Canada Occupational Health and Safety – 890N applied along top rail (200 lb)

LIFE CYCLE TESTING - BS 6375-2:2009 Clause 6.5 - Opening and closing of the hinge mechanism.

SALT SPRAY TESTING - ASTM B117 - 11 - 55 over 200 hours to assess performance of coating to resist corrosion.

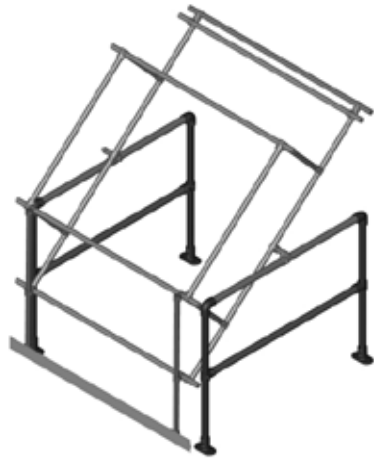

## TYPE A STANDARD PALLET GATE - SGPPTYAGV

Type A gate is balanced for a positive open and close action. This gate accepts pallets up to 1.4m x 1.48m with a maximum height capacity of 1.6m. Toe-board mounted on mezzanine edge side to protect workers below. Manufactured from steel to EN 10255 48.3 dia. x 3.2mm wall thickness tube and 33.7 dia. x 3.2mm wall thickness tube to meet requirements of EN 14122. Net Weight 95kg.



## TYPE B NARROW PALLET GATE - SGPPTYBGV

The Type B narrow frame pallet gate is perfect for use on mezzanines where space is limited. The design of this gate means less floorspace is required to load and unload. Balanced for a positive open and close action. This gate accepts pallets up to 1.4m x 1.48m with a maximum height capacity of 1.8m. Manufactured from steel to EN 10255 of 48.3 dia. x 3.2mm wall thickness tube and 33.7 dia. x 3.2mm wall thickness to meet requirements of EN 14122. Toe-board mounted on mezzanine edge side. Net Weight 95kg.



## TYPE C TALL PALLET GATE - SGPPTYCGV

The Type C gate offers the tallest capacity of the Kee Pallet Gates. The cantilever design of this gate provides maximum height with minimal ceiling height requirement. Balanced for a positive open and close action. This gate accepts pallets up to 1.4m x 1.48m with a maximum height capacity of 2.2m. Manufactured from steel to EN 10255 48.3 dia. x 3.2mm wall thickness tube and 33.7 dia. x 3.2mm wall thickness tube to meet requirements of EN 14122. Toe-board mounted on mezzanine edge side. Net Weight 105kg.



## TYPE D PREMIUM WIDE PALLET GATE - SGPPTYDAL

The Type D gate offers the widest load capacity of the Kee Pallet Gates. The design of this gate provides maximum load width, whilst also offering 2m head clearance for workers. Made from Aluminium and balanced for a positive open and close action. This gate accepts pallets up to 1.4m x 1.95m with a maximum height capacity of 1.6m. Manufactured from Grade 6082 T6 Aluminum 48.3mm dia. x 4mm wall thickness tube to meet requirements of EN 14122. Toe-board mounted on all sides to protect gates from pallet contact. Net Weight 75kg.

# Components for a Type A gate

## Colour coded diagram of components

Carefully take all the components out of the packaging and ensure all components listed on the next page have arrived.

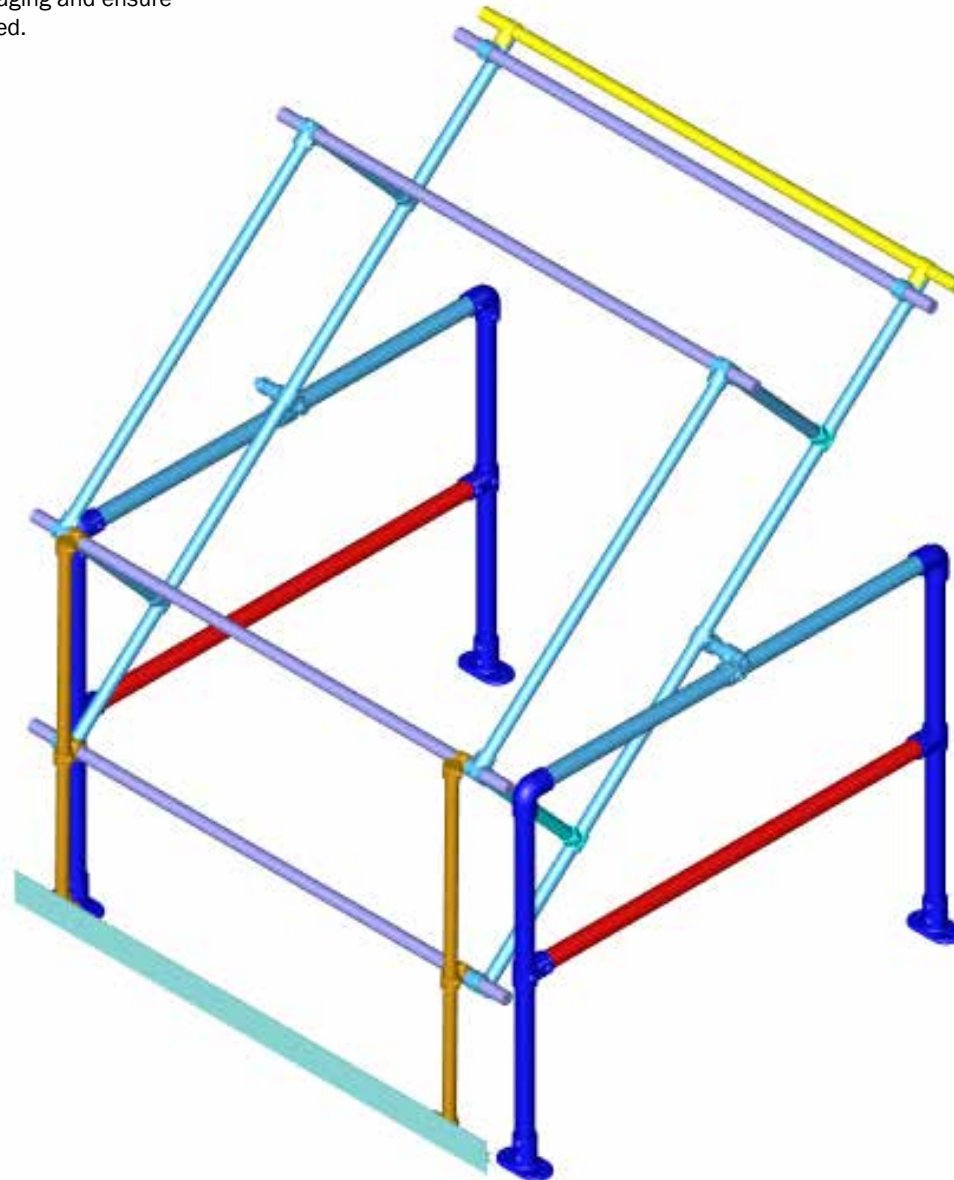

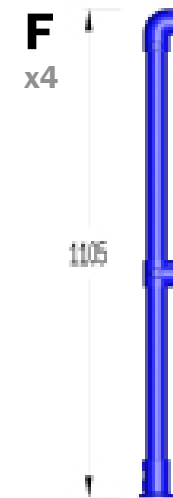
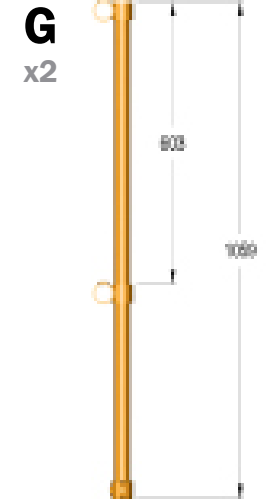
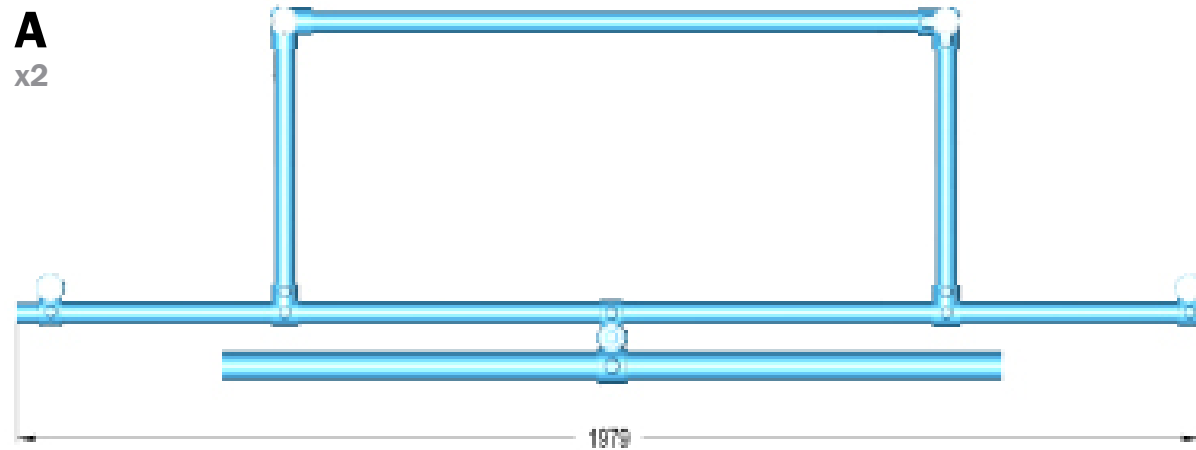

- Fixing items**
- 4no. M10 x 50mm Bolts
  - 4no. M10 Plain nuts
  - 4no. M10 Plain washers
  - 12no. Plastic end caps

## TOOLS REQUIRED

You will need the following in order to install the Kee Pallet Gate:

- Marker Pen
- Tape Measure
- 2No. 30mm Ring Spanners
- 1No. 17mm Ring Spanner
- 1/4" Hex Key/Socket
- 5/16" Hex Key/Socket
- Torque Wrench 10- 60 Nm approx
- Small Magnetic Level
- Floor fixings to suit surface

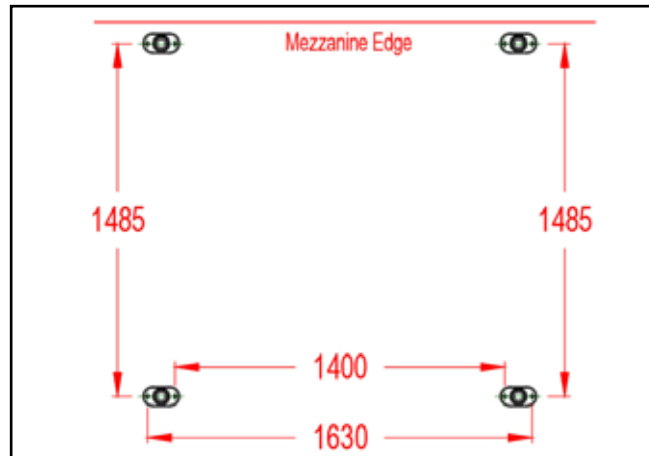

1. Using the above guide mark the position of the holes. Carefully drill a 12mm hole on each mark. Remove any debris using suitable extraction equipment.

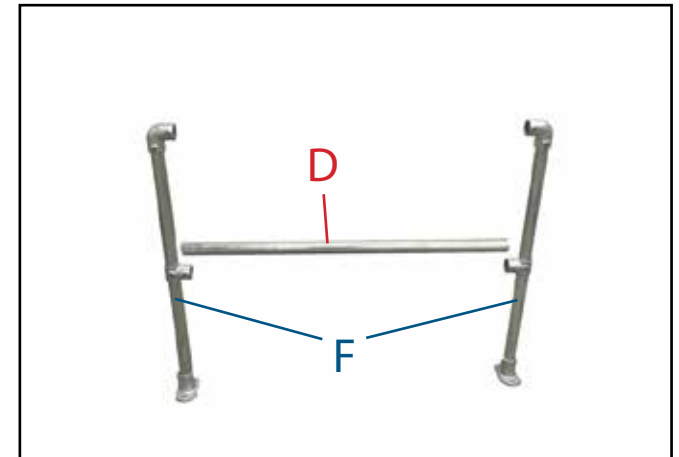

2. Build 2No frames using 2No. (F) uprights, 1No. (D) horizontal per frame. Once tubes are fully inserted tighten grub screws using 5/16" hex key.



3. Align each frame to the pre-drilled holes. Slight adjustment of the fittings may be necessary to centre correctly with the holes.

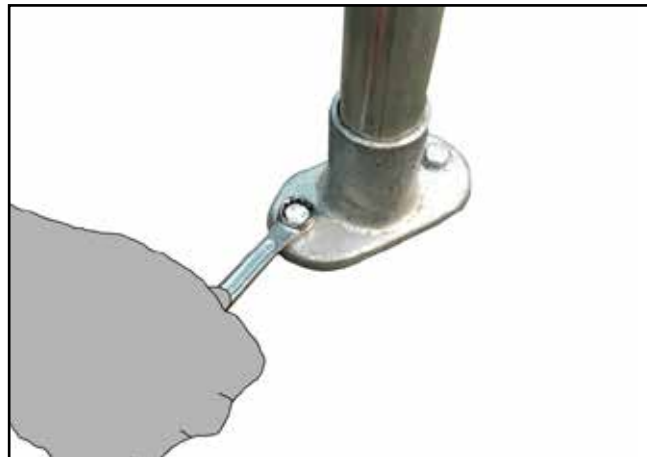

4. Using the 4No (62-8) castings at the base of the frame legs mount all 4No. feet to the floor. Ensure fixings are torqued as per suppliers' guidelines.

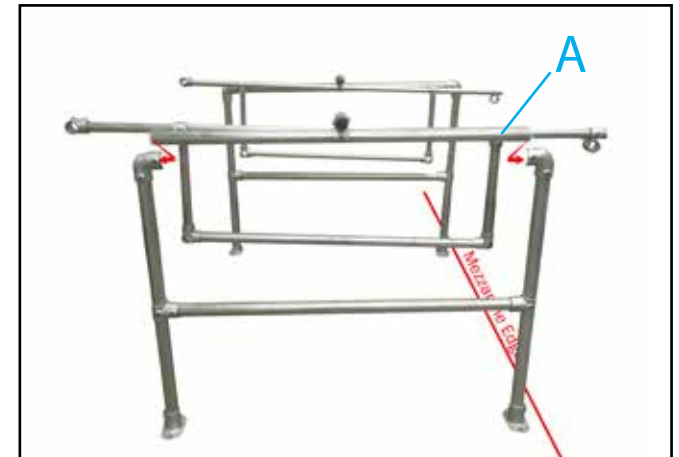

5. Take part (A) with hinge arm and mount wide size 8 (48.3mm dia) tube to frame with gate rail on inner side. Repeat this step for other frame. NB. Slight loosening of the frame may be required to allow the horizontal to be inserted into the frame.

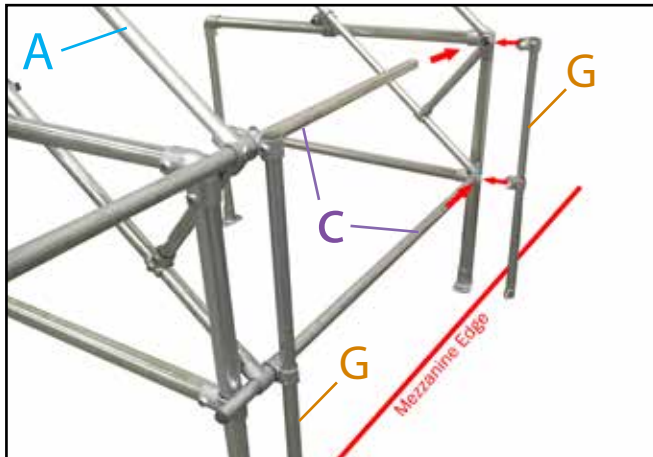

**6.** Rotate cantilever part (A) so this is as above. Add 2no. part (C) horizontal tubes on mezzanine edge end and add part (G) upright tubes as above onto parts (C) during the process. Tighten using 1/4" hex key.

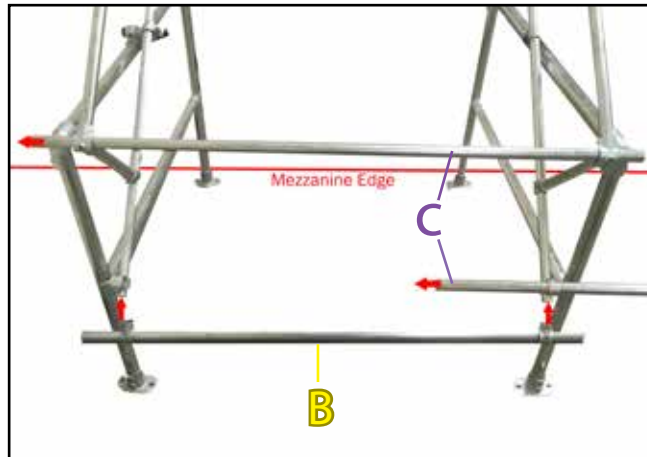

**7.** On opposite end to mezzanine edge add 2no. part (C) horizontal tubes to upper and lower cantilever tubes. Then add part (B) onto ends of lower cantilever tubes. Tighten using 1/4" hex key.

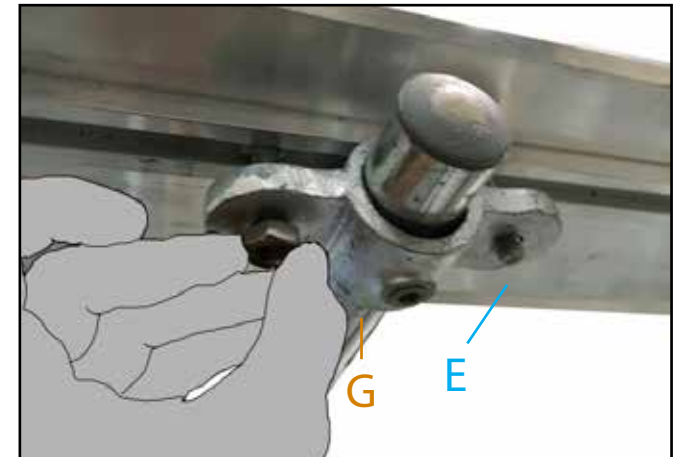

**8.** Mount toe-board (E) part to the (G) uprights by sliding 4No. bolt heads into the track along the back of the toe-board. Carefully align 2No. bolts so they fit through each of the M51-6 fitting. Add the washer and nut and loosely tighten to permit movement within the toe-board for adjustment in next step.



**9.** Check toe-board is central within the frame and tighten nuts to 15Nm to ensure it is held securely in place.

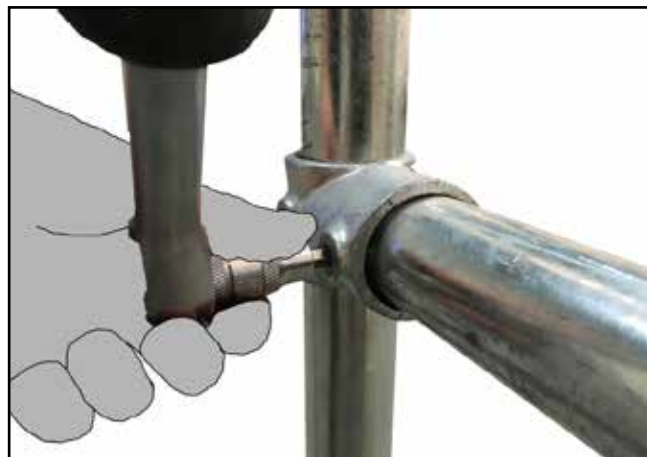

**10.** Ensure all fittings are correctly torqued to 39Nm and all tubes are level. Ensure gate operates smoothly and opens and closes positively.

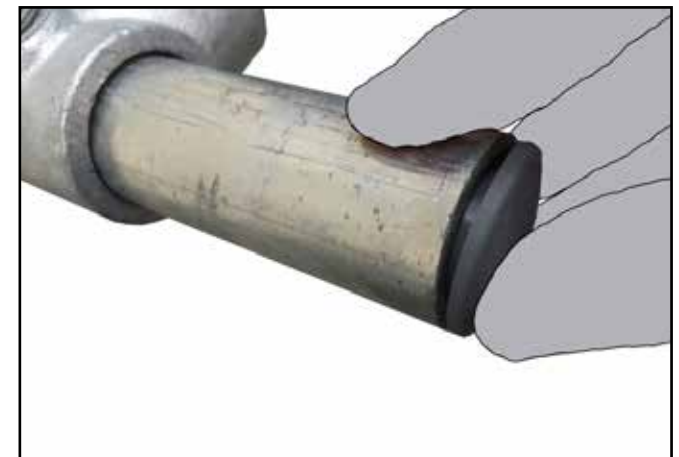

**11.** Place plastic end caps on all exposed tube ends. These may need to be tapped into place using a rubber mallet.

**Note:- Installing Kee Pallet Gate**

Ensure gate fittings are correctly torqued. Establish that the gate will close correctly. Failure to do so could result in death or serious injury.

# Components for a Type B Gate

## Colour coded diagram of components

Carefully take all the components out of the packaging and ensure all components listed on the next page have arrived.

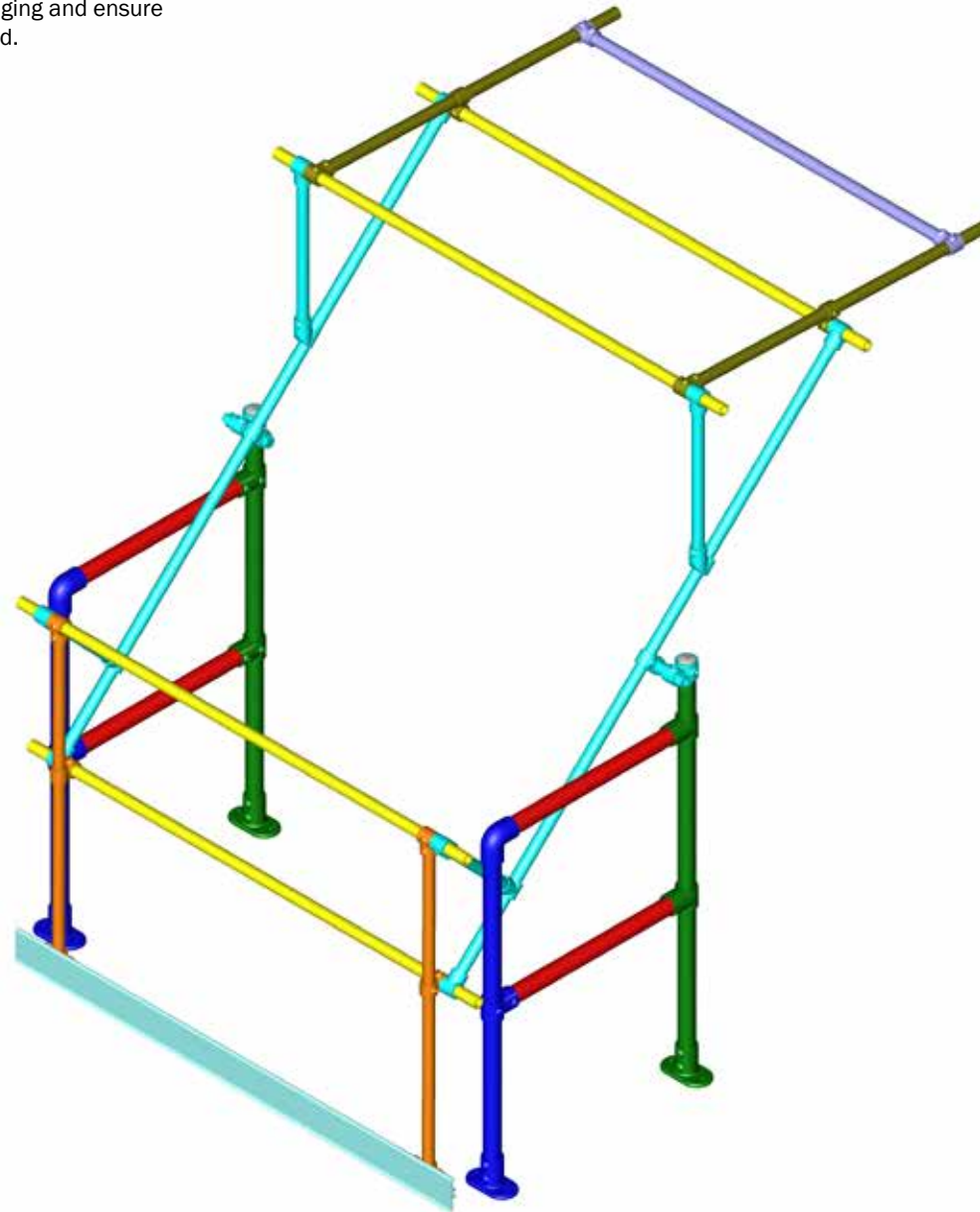

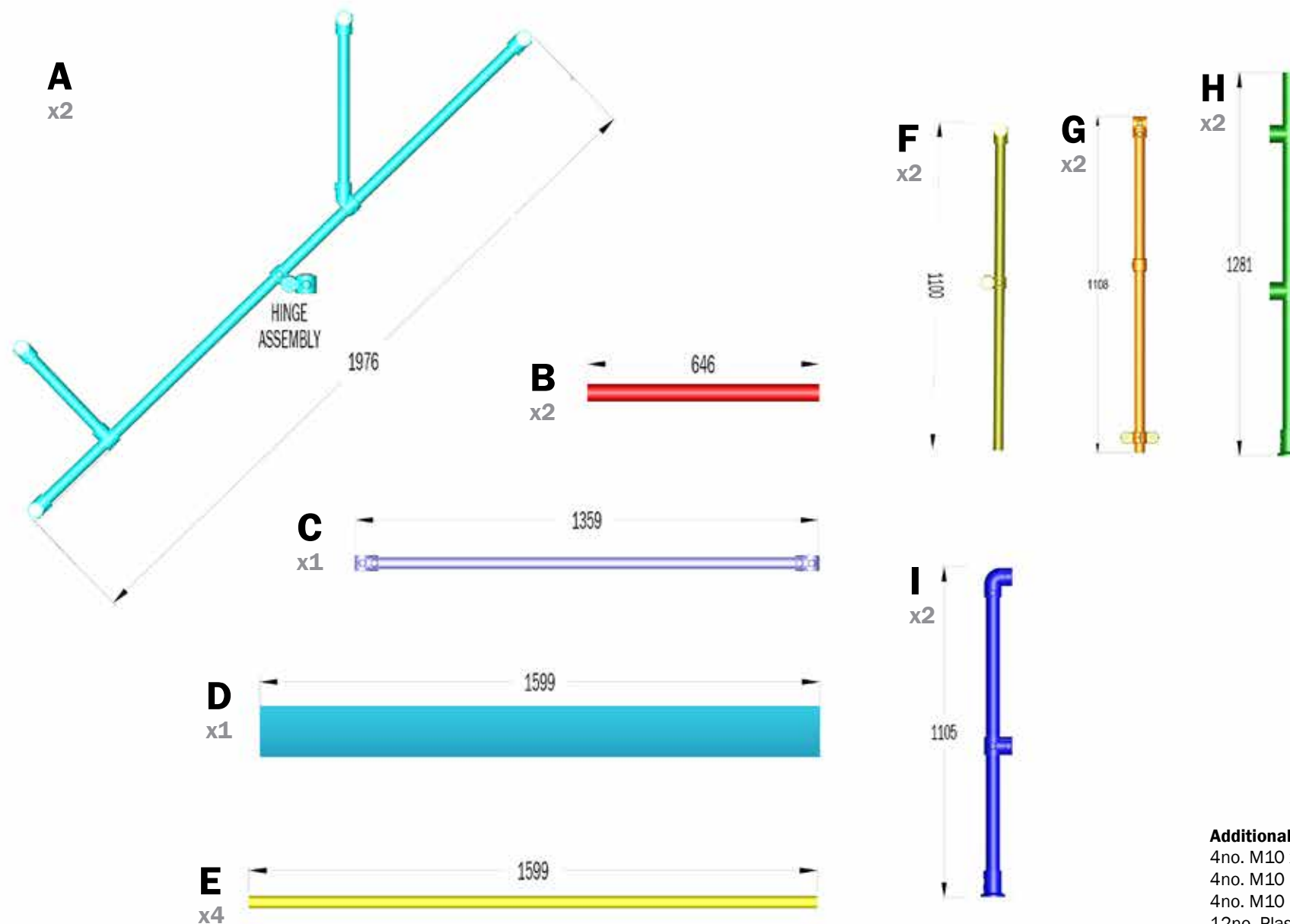

**Additional items**  
 4no. M10 x 50mm Bolts  
 4no. M10 Plain nuts  
 4no. M10 Plain washers  
 12no. Plastic end caps

## TOOLS REQUIRED

You will need the following in order to install the Kee Pallet Gate:

- Marker Pen
- Tape Measure
- 2No. 30mm Ring Spanners
- 1No. 17mm Ring Spanner
- 1/4" Hex Key/Socket
- 5/16" Hex Key/Socket
- Torque Wrench 10- 60 Nm approx
- Small Magnetic Level
- Floor fixings to suit surface

**Establish that the gate will close correctly!! Failure to do so could result in Death or serious injury.**

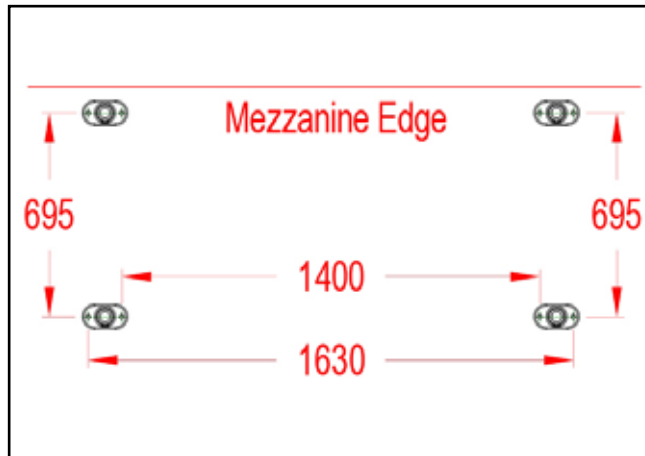

**1.** Using the above guide mark the position of the holes. Carefully drill a 12mm hole on each mark. Remove any debris using suitable extraction equipment.

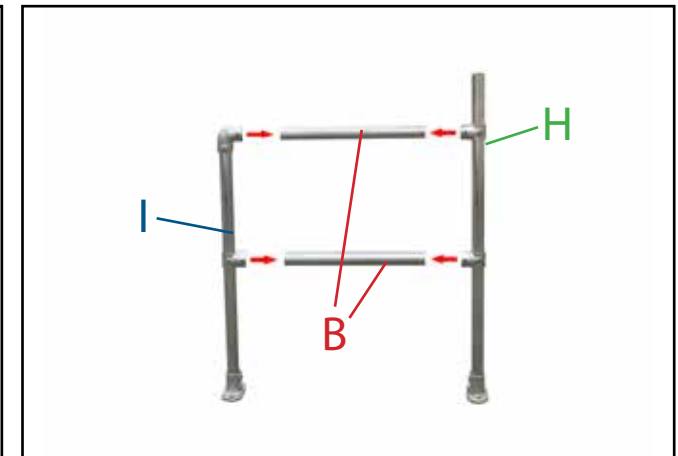

**2.** Build 2No frames using 1No. (H) upright, 1No. (I) upright and 2No. (B) horizontal parts per frame. Once tubes are fully inserted tighten grub screws using 5/16" hex key.



**3.** Align each frame to the pre-drilled holes. Slight adjustment of the fittings may be necessary to centre correctly with the holes.

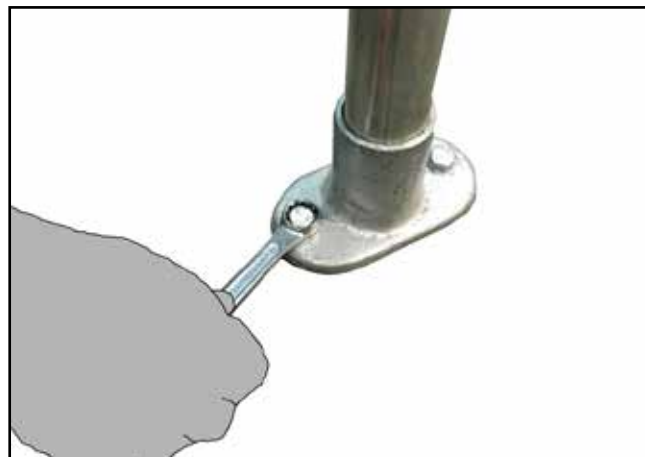

**4.** Using the 4No (62-8) castings at the base of the frame legs mount all 4No. feet to the floor. Ensure fixings are torqued as per suppliers' guidelines.

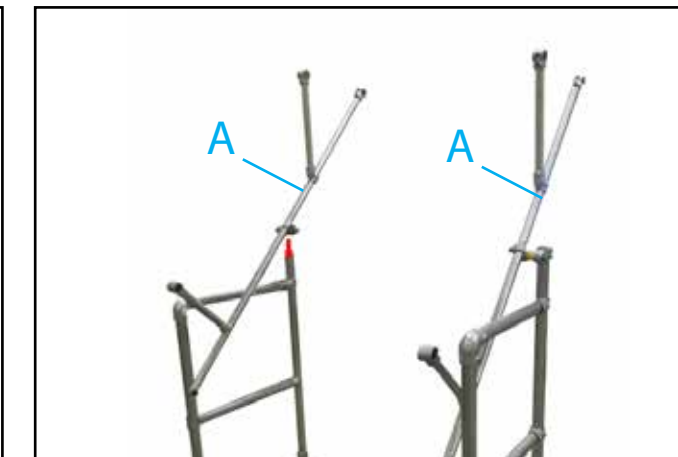

**5.** Take part (A) with bearing attached and with gate rail on inner side mount to the vertical tube of the frame. Ensure bearing is facing mezzanine edge side as per diagram above. Repeat this step for other frame.



6. Ensure frame is parallel. If not, the gate will not operate smoothly. Adjust this if necessary by rotating the fittings. Note location of hinge mechanism as mentioned in previous step.

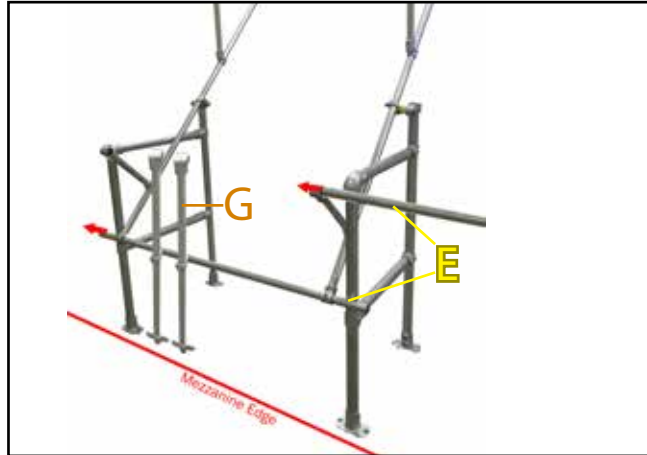

7. On Mezzanine leading edge slide 2no. part (E) horizontal tubes through the cantilever tube ends. During this process add 2no. part (G) vertical uprights with toe-board brackets onto horizontal tubes part (E).

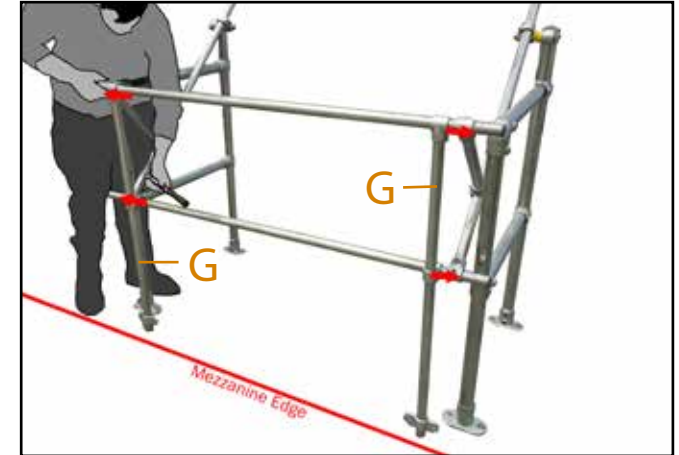

8. Slide part (G) vertical uprights to the left and right hand side of horizontals as shown above. Tighten using 1/4" hex key.

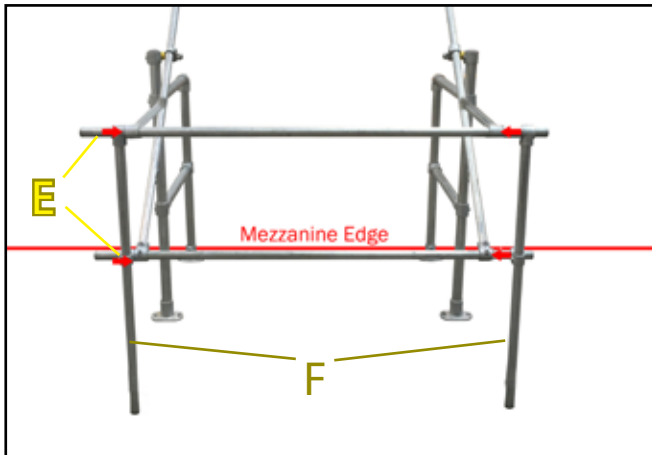

9. On opposite end to mezzanine edge slide 2no. part (E) horizontal through cantilever tube ends. Add 2no. (F) uprights onto ends of horizontal tubes. Tighten using 1/4" hex key.

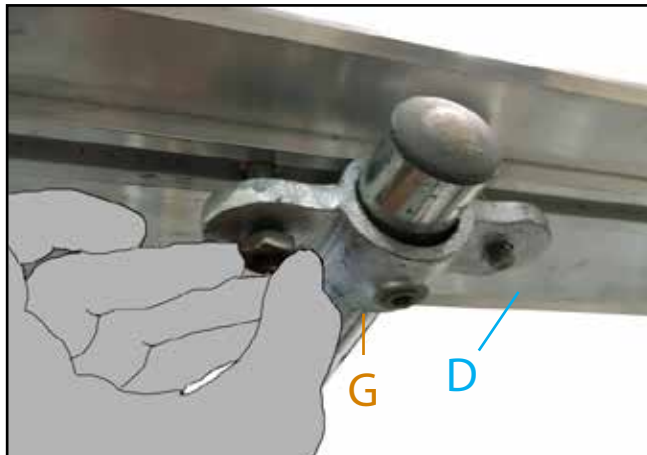

10. Mount toe-board (D) part to the I uprights by sliding 4No. bolt heads into the track along the back of the toe-board. Carefully align 2No bolts so they fit through each of the M51-6 fitting. Add the washer and nut and loosely tighten to permit movement within the toe-board for adjustment in next step.



11. Check toe-board is central within the frame and tighten nuts to 15Nm to ensure it is held securely in place.

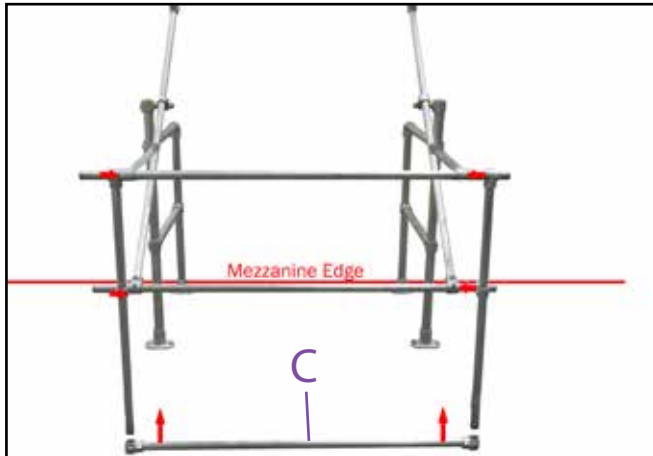

**12.** On opposite end to mezzanine edge insert part (C) horizontal tube by sliding tube 100mm up the vertical posts. Tighten using 1/4" hex key.

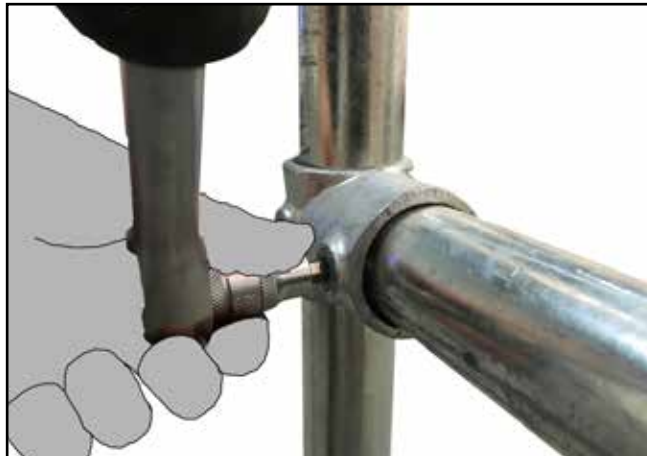

**13.** Ensure all fittings are correctly torqued to 39Nm and all tubes are level. Ensure gate operates smoothly and opens and closes positively.

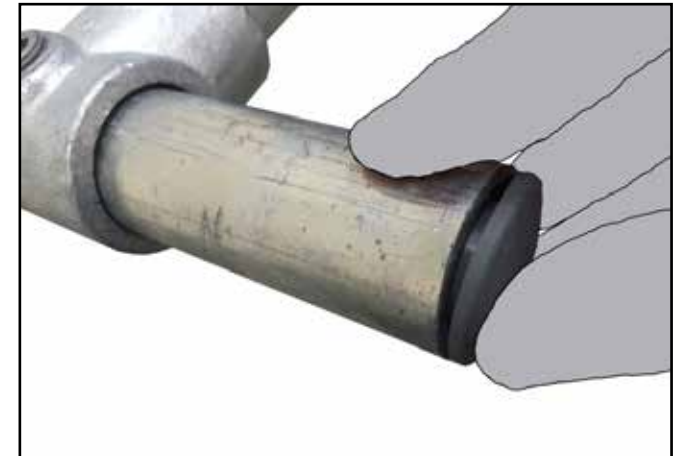

**14.** Place plastic end caps on all exposed tube ends. These may need to be tapped into place using a rubber mallet.

**Note:- Installing Kee Pallet Gate**

Ensure gate fittings are correctly torqued. Establish that the gate will close correctly. Failure to do so could result in death or serious injury.

# Components for a Type C gate

## Colour coded diagram of components

Carefully take all the components out of the packaging and ensure all components listed on the next page have arrived.

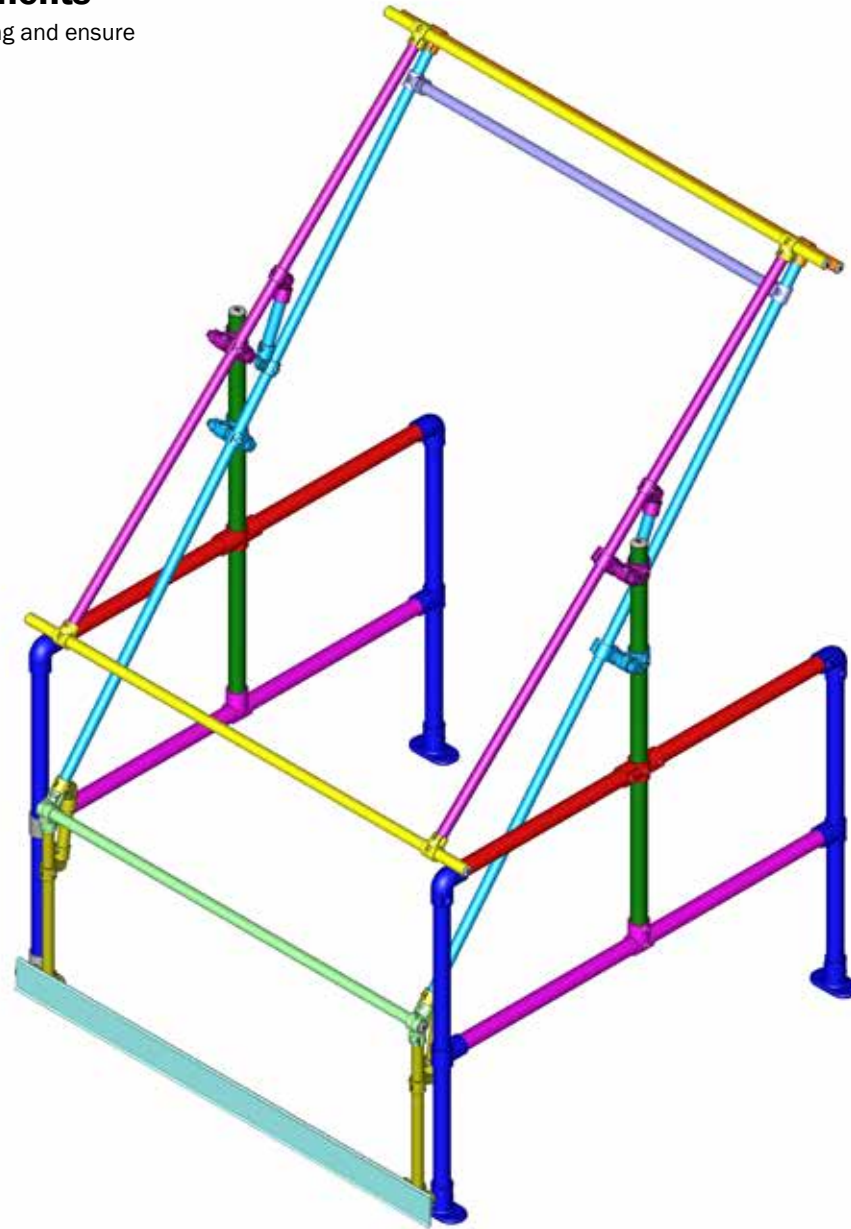

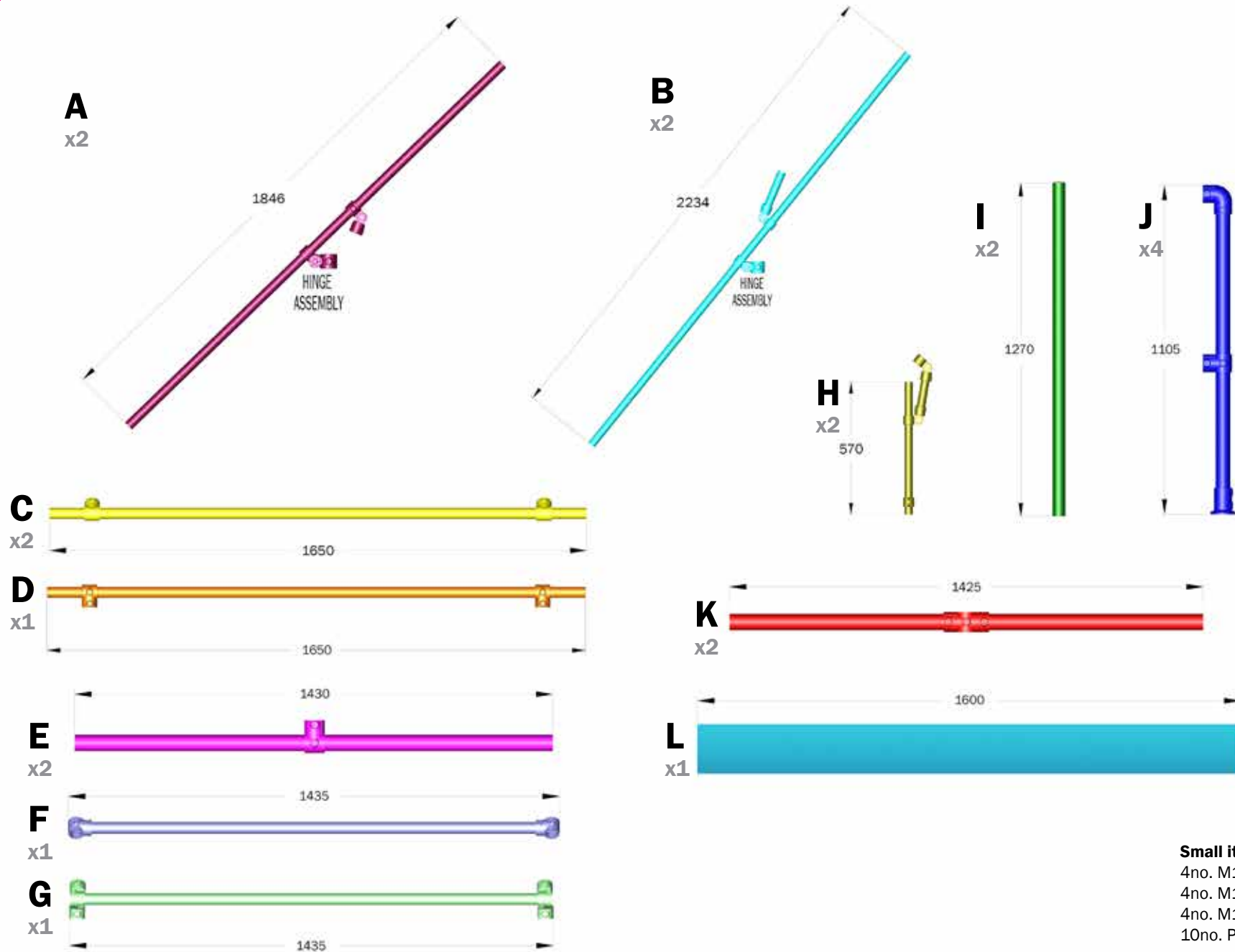

All measurements are shown in mm

## TOOLS REQUIRED

You will need the following in order to install the Kee Pallet Gate:

- Marker Pen
- Tape Measure
- 2No. 30mm Ring Spanners
- 1No. 17mm Ring Spanner
- 1/4" Hex Key/Socket
- 5/16" Hex Key/Socket
- Torque Wrench 10- 60 Nm approx
- Small Magnetic Level
- Floor fixings to suit surface

**Establish that the gate will close correctly!! Failure to do so could result in Death or serious injury.**

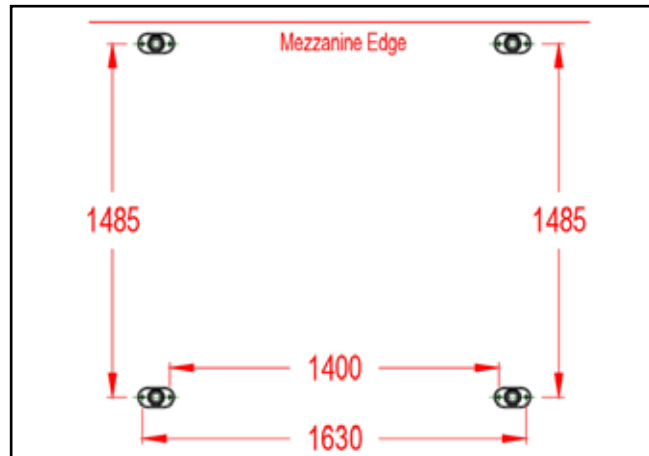

**1.** Using the above guide mark the position of the holes. Carefully drill a 12mm hole on each mark. Remove any debris using suitable extraction equipment.

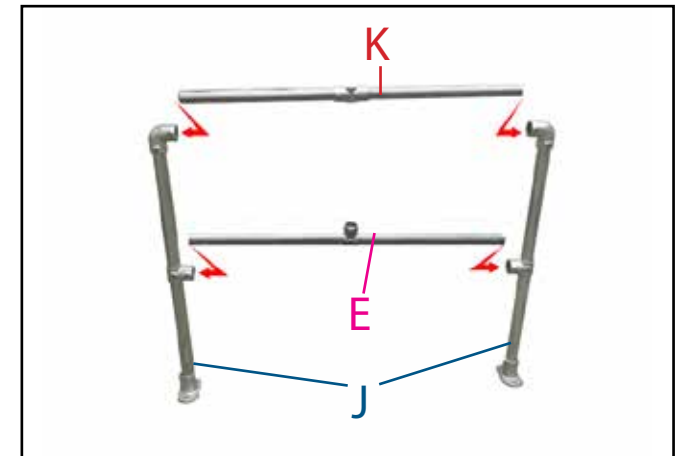

**2.** Build 2 frames using 2no. (J) uprights, 1no. (E) horizontal for the lower horizontal and 1no. (K) for the upper horizontal per frame. Once tube is fully inserted tighten grub screws using 5/16" hex key.



**3.** Align each frame to the pre-drilled holes. Slight adjustment of the fittings may be necessary to centre correctly with the holes.

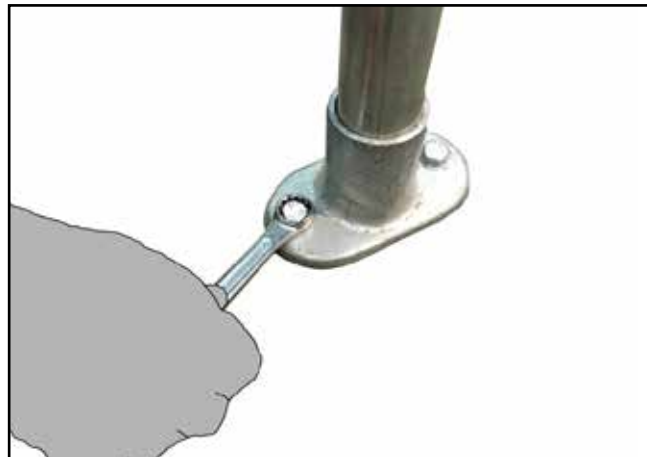

**4.** Using the 4No. (62-8) castings at the base of the frame legs mount all 4No. feet to the floor. Ensure fixings are torqued as per suppliers' guidelines.

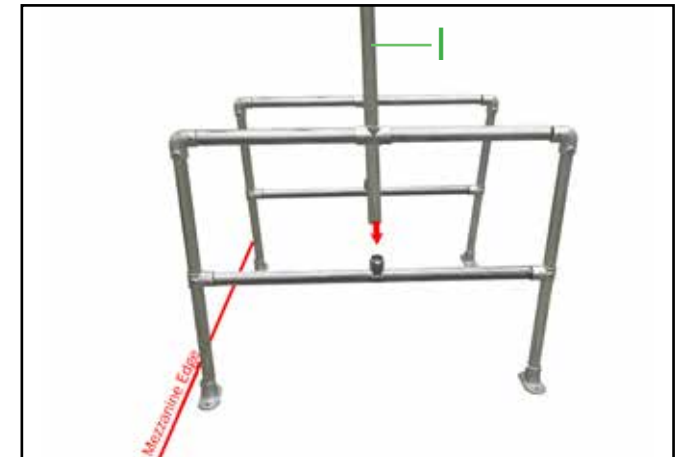

**5.** Slide part (I) upright rail through fittings on each frame. Tighten grub screws. Repeat for other frame.

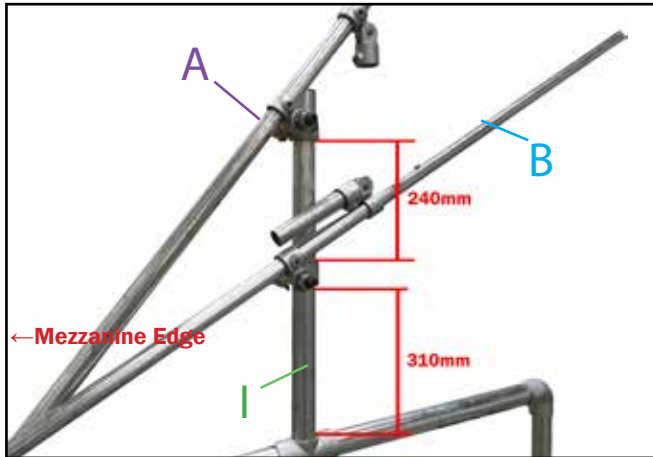

**6.** Carefully measure and mark 310mm from top of frame as shown above. Slide part (B) onto part (I) and mount fitting at this mark, ensuring bearing is on the inside of the frame then tighten grub screw. Measure and mark 240mm from top of fitting on part (B). Add part (A) to part (I) mounting the fitting to this mark ensuring bearing is facing same direction and tighten grub screw. Repeat process for other frame.



**7.** Ensure frame is parallel. If not, the gate will not operate smoothly. Adjust as necessary by rotating the fittings.

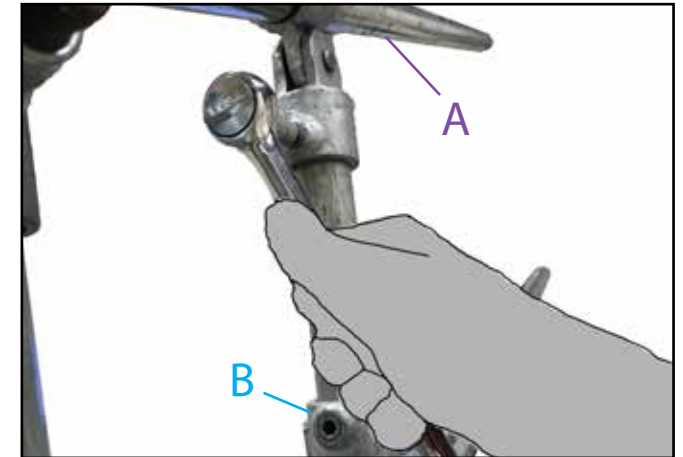

**8.** Connect cantilever tube link post form part (B) and connect into fitting on part (A). This will link the two tubes and allow the concertina action.

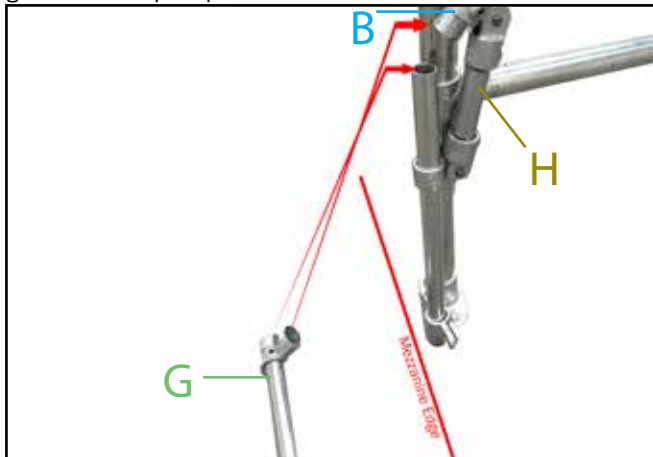

**9.** Add part (H) upright by sliding fitting onto end of part (B) on mezzanine leading edge end of the gate and tighten grub screw. Then linking part (G) horizontal tube to exposed tube ends on part (H) and part (B). Tighten fittings using 1/4" hex key.

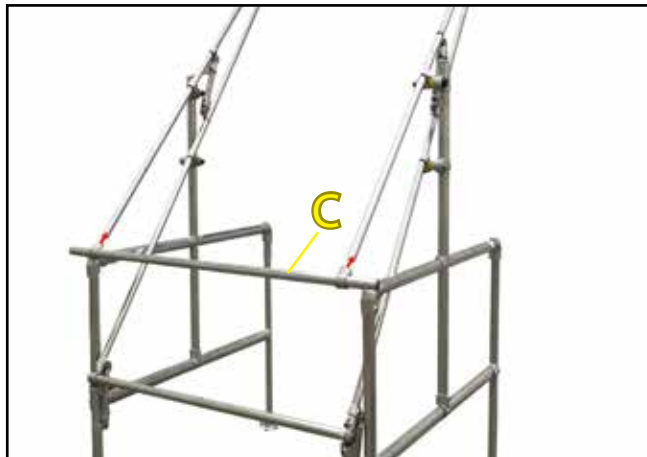

**10.** Add 1no. part (C) horizontal tube to mezzanine floor edge end as in diagram above. Tighten using 1/4" hex key.

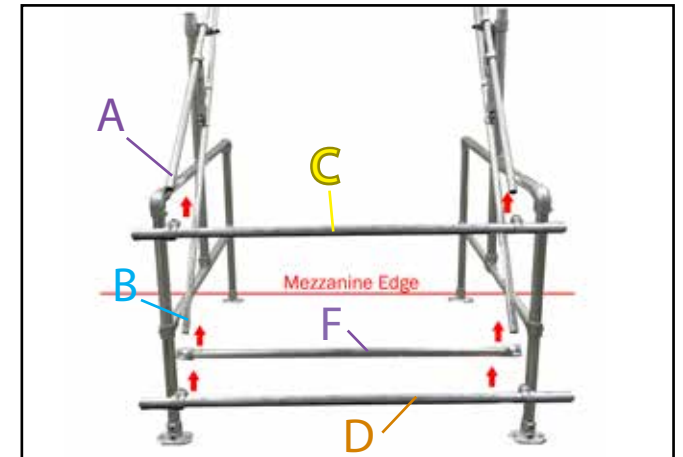

**11.** On opposite end to mezzanine edge mount horizontal tube part (C) to upper cantilever rails (A). Slide part (F) 150mm up part (B) cantilever tubes and tighten using 1/4" hex key. Mount horizontal tube part (D) to lower cantilever rails (B). Tighten fittings using 1/4" hex key.

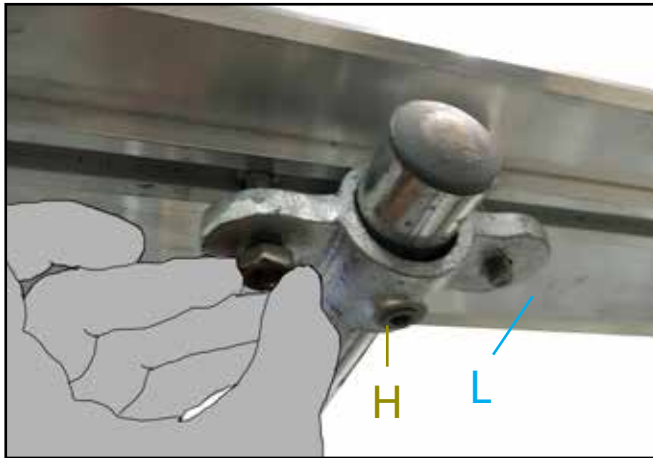

**12.** Mount toe-board (L) to part (H) uprights by sliding 4no. bolt heads along back of toe-board and then inserting 2no. bolts into each fitting. Loosely add washer and nut allowing movement within the toe-board for adjustment in next step.



**13.** Check part (H) toe-board is central within the frame and tighten nuts to 15Nm to ensure it is held securely in place.

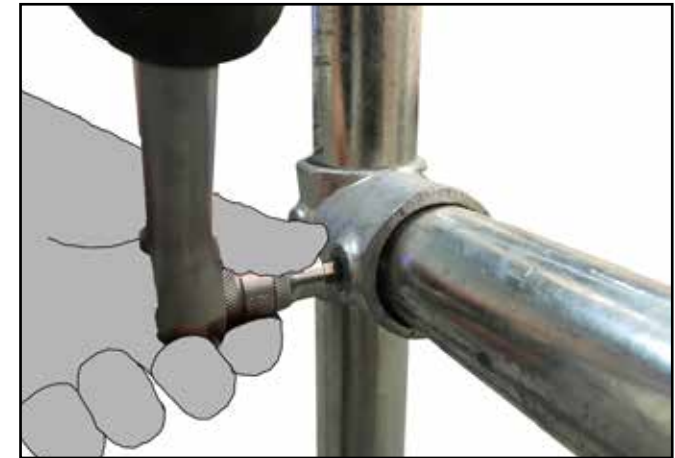

**14.** Ensure all fittings are correctly torqued to 39Nm and all tubes are level. Ensure gate operates smoothly and is balanced.

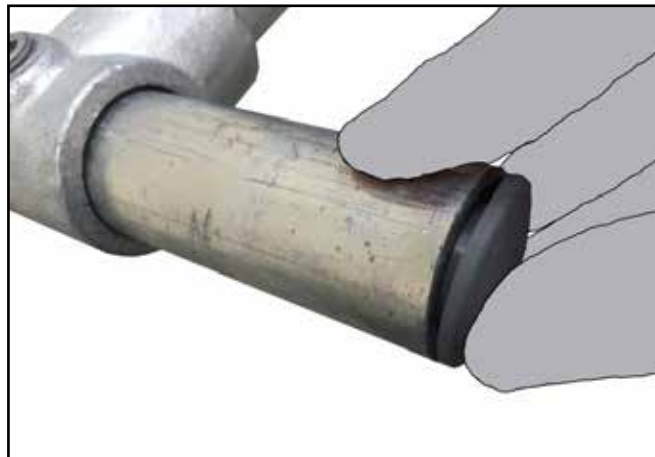

**15.** Place plastic end caps on all exposed tube ends. These may need to be tapped into place using a rubber mallet.

**Note:- Installing Kee Pallet Gate**

Ensure gate fittings are correctly torqued. Establish that the gate will close correctly. Failure to do so could result in death or serious injury.

## Colour coded diagram of components

Carefully take all the components out of the packaging and ensure all components listed on the next page have arrived.

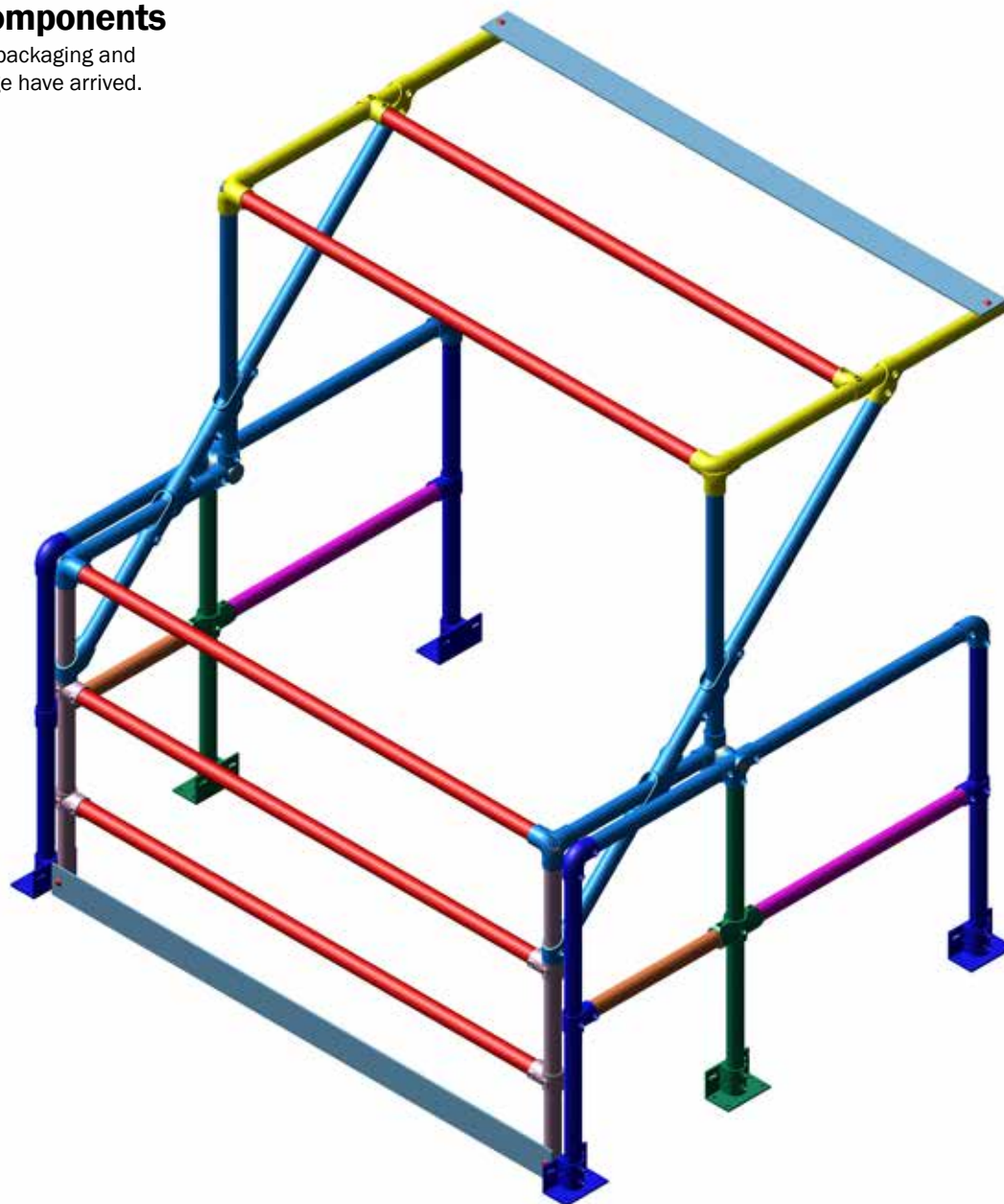

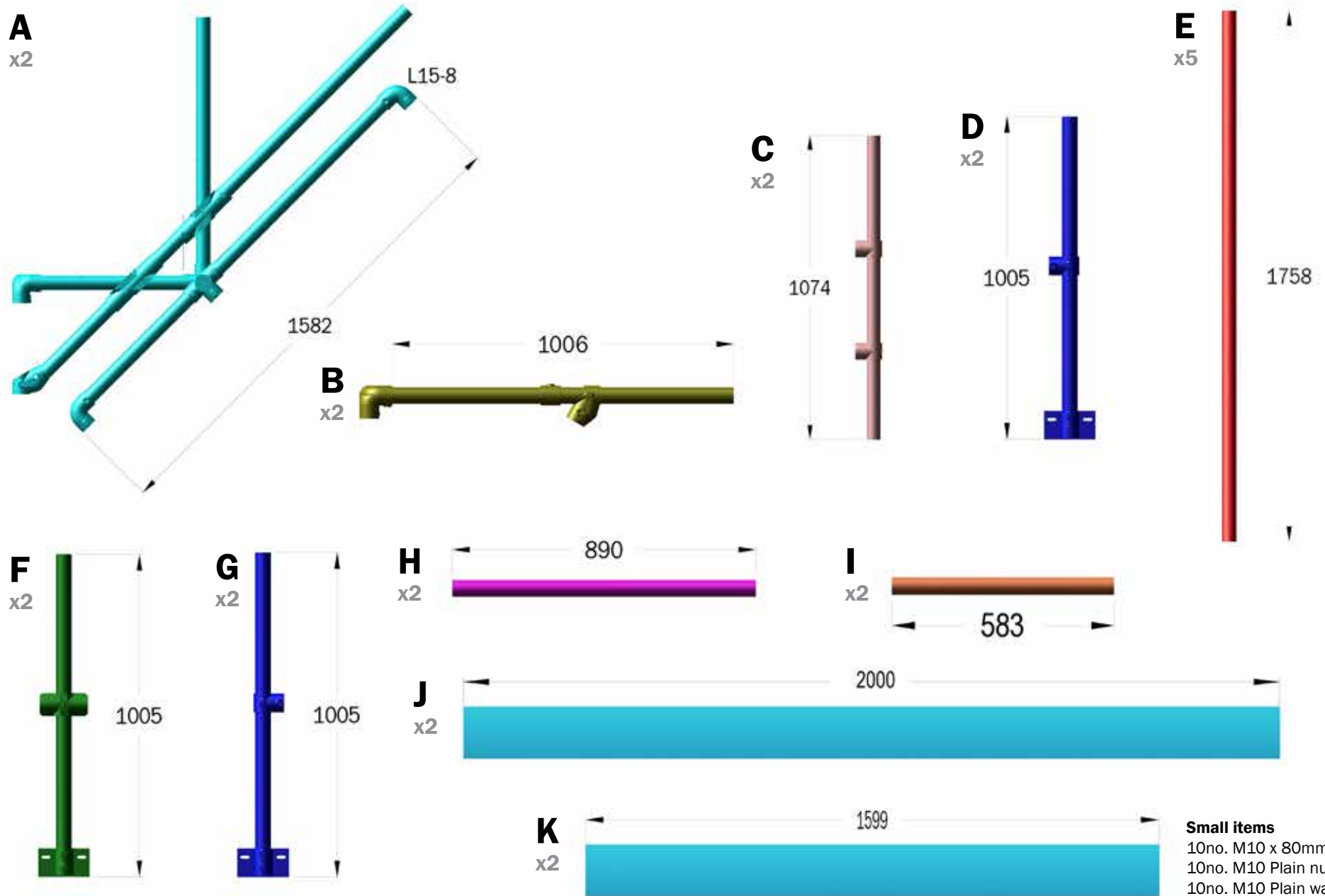

All measurements are shown in mm

## TOOLS REQUIRED

You will need the following in order to install the Kee Gate Pallet Gate:

- Marker Pen
- Tape Measure
- 2No. 30mm Ring Spanners
- 1No. 17mm Ring Spanner
- 5/16" Hex Key/Socket
- Torque Wrench 10- 60 Nm approx
- Small Magnetic Level
- Floor fixings to suit surface

**Establish that the gate will close correctly!! Failure to do so could result in Death or serious injury.**

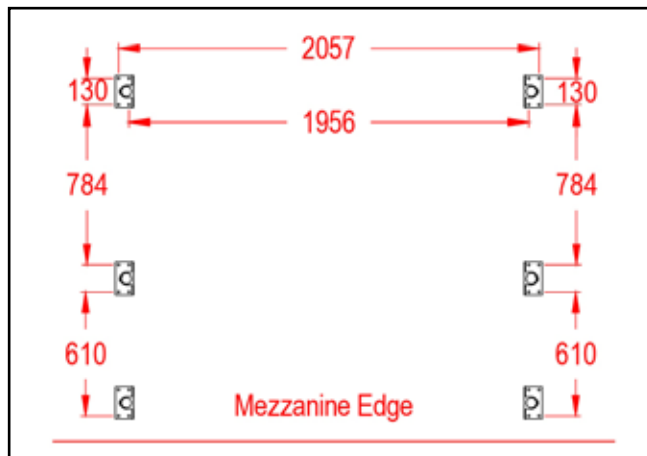

**1.** Lay components on safe flat working area. Using adequate fall protection device drill 12mm holes to allow feet to be attached using the above guide.

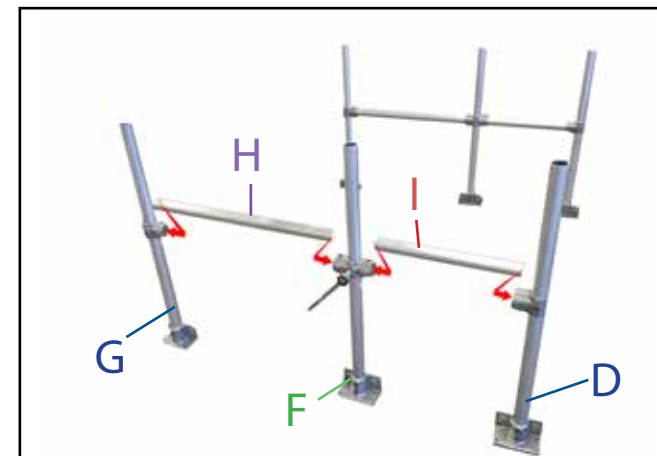

**2.** Build 2 frames using 1no. (D) part, 1no. (F), 1no. (G) per frame as above. Link upright posts using 1no. part (H) and 1 no. part (I) per frame and tighten grub screws using 5/16" hex key. Repeat process to make second frame.



**3.** Align each frame to the pre-drilled holes. Slight adjustment of the fittings may be necessary to centre correctly with the holes. As per drawing, the frame uprights are off centre, so the centre post should be closer to the leading edge of the mezzanine.



**4.** Mount each of the six (L69-8) feet on frame using suitable floor fixings. Ensure fixings are torqued as per suppliers' guidelines.

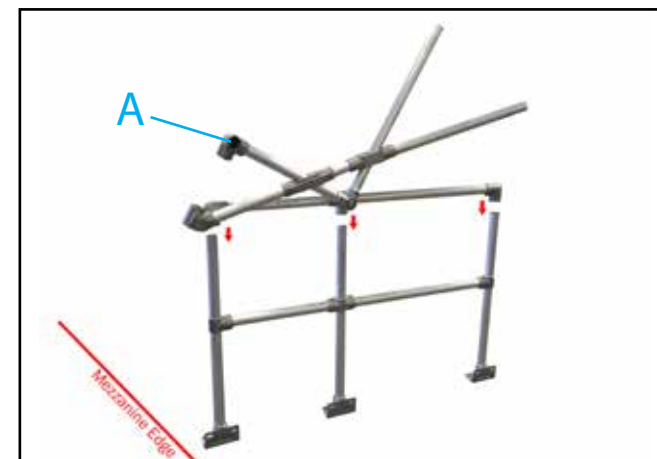

**5.** Add part (A) cantilever arms onto the frame, ensuring that the arm is positioned on the inside of pallet gate. Repeat for opposite frame.

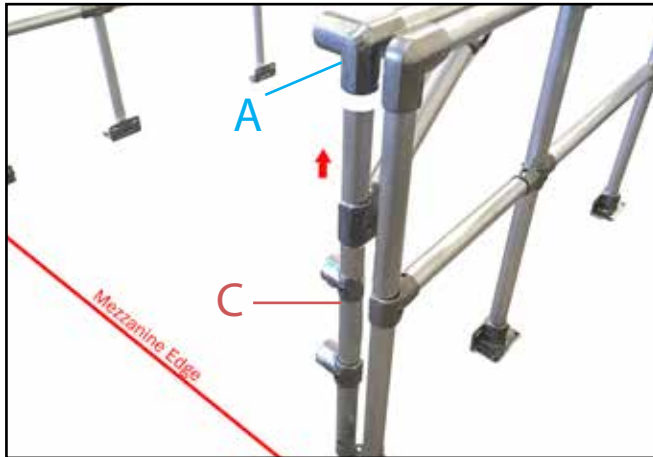

**6.** Add part (C) uprights into end of part (A) with fittings pointing inwards towards each other and tighten grub screws.

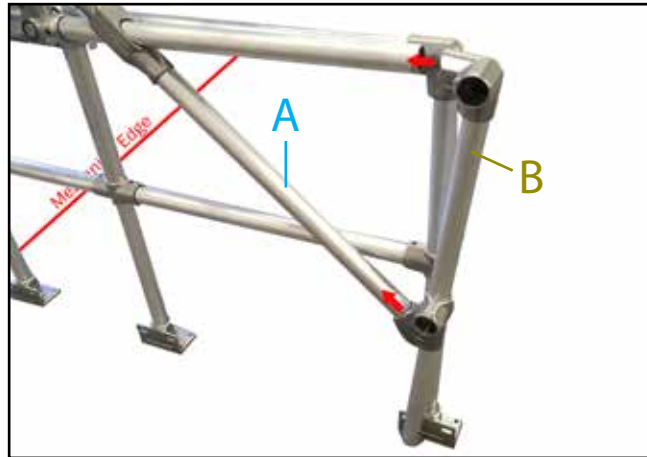

**7.** Add part (B) upright tubes onto opposite end of part (A), insert tubes into fittings as per above and tighten grub screws using hex key.

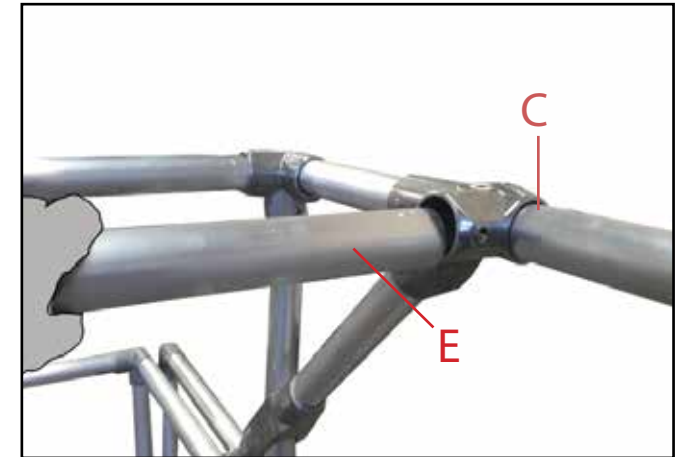

**8.** Insert 2no. part (E) horizontal tube to link up left and right hand cantilever sections. Tighten grub screws using hex key.

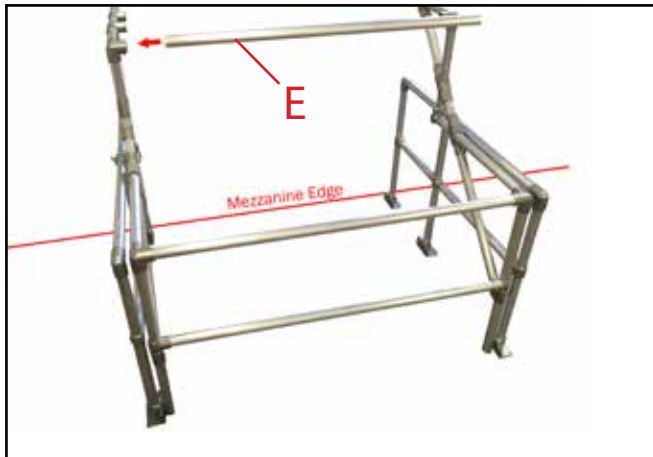

**9.** Repeat process for other side of gate using 3no. part (E) horizontal tubes. Once tubes have been inserted tighten grub screws and torque to 39Nm.

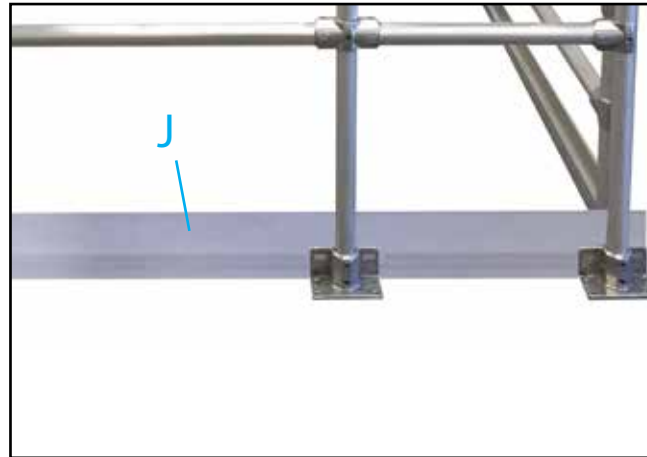

**10.** Add part (J) toe-board onto both left and right hand side frames using M10 nuts and bolts provided.

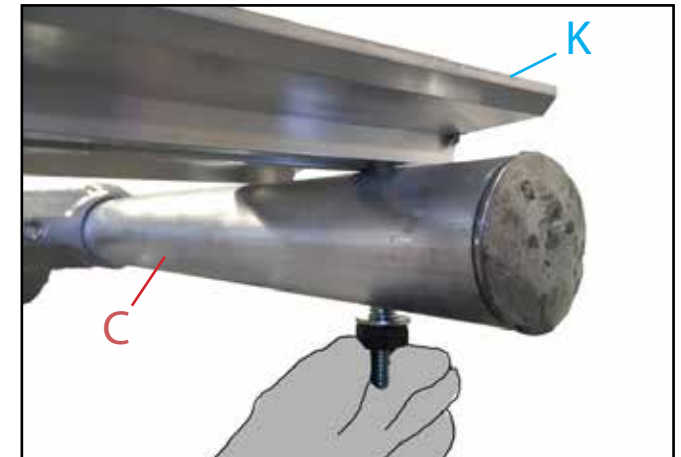

**11.** Add 1no. part (K) toe-board to part (C) uprights. Thread M10 bolt through hole in upright and add nut and washer. Tighten to 15Nm.

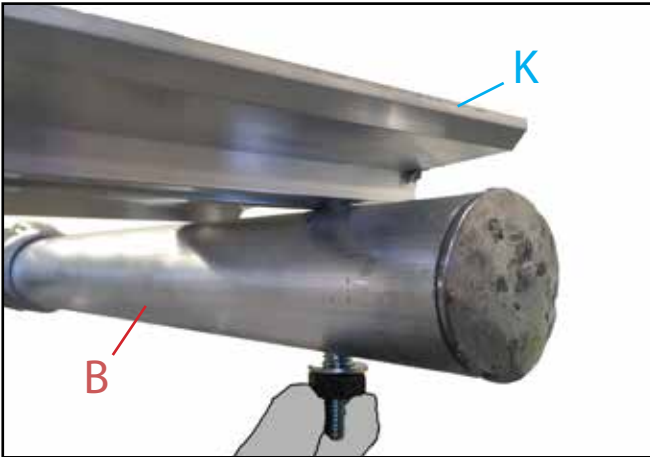

**12.** Add 1no. part (K) toe-board to part (B) uprights. Thread M10 bolt through hole in upright and add nut and washer. Tighten to 15Nm.

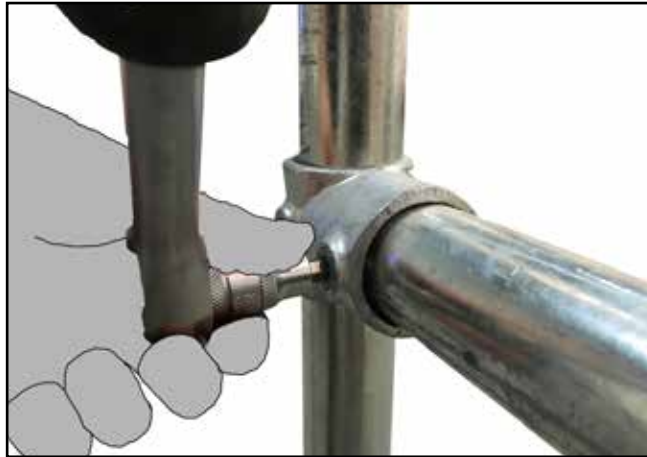

**13.** Ensure to fittings are torqued to 39Nm, that the pallet gate operates smoothly and is balanced.

**Note:- Installing Kee Pallet Gate**

Ensure gate fittings are correctly torqued. Establish that the gate will close correctly. Failure to do so could result in death or serious injury.

Periodic inspections by a competent person are recommended by the manufacturer. In UK/Europe these are required under Regulation 5 of the Workplace (Health, Safety & Welfare) Regulations, the Work at Height Regulations and Provision and Use of Work Equipment Regulations.

The frequency will depend upon the environment, location and usage but should be at least every 12 months.

- Visually inspect the complete installed product in relation to the general client's needs. Establish if any modifications and/or additional products are required to reflect any refurbishment requirements or additional plant & equipment which have been installed and require material access.
- Check installation configuration is complete as per the original installation drawing/plan.
- Ensure the product has not been modified or tampered with by unauthorised persons.
- Check the functionality of the product.
- Check all fixings are in place and sufficiently torqued.
- Check the general height and level of the product.
- Any galvanised components showing signs of corrosion should be wire brushed thoroughly and galvanised spray/paint applied as appropriate. If rusted significantly, take digital photographs and include these in the inspection report.
- Inspect aluminium/stainless steel and powder coated product surfaces and note any imperfections or general degradation.
- Check fixings to walls/structures and sufficiently torqued.
- Check system plaque position & mark up to reflect date of the next required inspection. Establish if additional plaques are required due to any refurbishment works.





**Kee Safety Limited**  
Cradley Business Park  
Overend Road, Cradley Heath  
West Midlands B64 7DW  
United Kingdom

**Phone: +44 (0) 1384 632 188**  
Fax: +44 (0) 1384 632 192

sales@keesafety.com  
**www.keesafety.co.uk**