

Full-element Analysis

Rapid Accurate Non-destructive

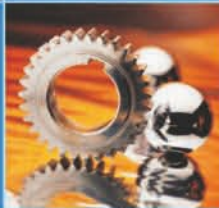

Cement



Steel and other
nonferrous
metals



RoHS

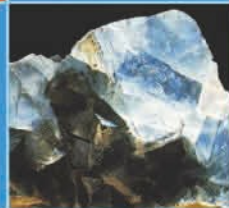

Aggregate



EDX 3600B

**X-ray Fluorescence
Spectrometer**

Full-element Analysis Expert

EDX 3600B

Engaged in cement, steel, nonferrous metals, aggregate and RoHS detection



Rapid
Accurate
Non-destructive

The cost effective world-leading X-ray generator and high-voltage unit make the instrument produce results compliant with State standards.

The instrument is specially designed for metallurgy and building material industry.

**Precision Instruments
Made in Skyray**

XRF technology is used in EDX3600B X-ray Fluorescence spectrometer for rapid and accurate elemental analysis. The technology features low-energy X-ray which generates good excitation results of light elements such as Si, S, Na and Mg. Moreover, with short test time, the test efficiency has been significantly improved. EDX3600B has good energy linearity, energy resolution, spectrum property and high peak-background ratio by using UHRD detector. It is consistent due to the automatic spectrum stabilizing device. The original spectrum can be easily decoupled by applying UHRD technology, which improves the measured analytical precision of light elements of Si, S, Al, etc. Owing to multi-parameter linear regression method, the absorption and repelling effects between elements can be highly reduced.



Performance traits

- It performs professional full-element analysis on cement, steel, aggregate, plating thickness detection and RoHS.
- In-built SNE improves the signal processing ability up to 25 times.
- The collimators and filters can be switched automatically for different samples.
- Electro-cooling UHRD detector instead of liquid nitrogen cooling detector
- Intelligent full-element analysis software matches with the hardware well.

Product Parameters

Name: Skyray X-ray Fluorescence Spectrometer

Model: EDX3600B

Input Voltage: AC 110V/220V

Consumed Power: 200W

Ambient Temperature: 15°C-30°C

Ambient Humidity: 35%-70%

Area of Sample Chamber: 320mm × 180mm

Size: 650mm × 608mm × 466mm

Weight: 75kg

Unique configurations

- Signal-to-Noise Enhancer (SNE)
- Light path enhancement system
- Electro-cooling UHRD detector
- In-built high resolution camera
- Automatic collimator and filter switch
- Precise mobile platform
- Enhanced metal sensitivity analyzer

Technical specifications

Range of measurable elements: Na to U

Range of element content: 1ppm-99.99%

Ability of simultaneous analysis: 24 elements

Functions: full-element analysis of cement, steel and aggregate

Plating thickness: more than 11 layers, up to 0.005um each layer

Analysis accuracy: 0.05%

Forms of samples: powder, solid and liquid

Testing time: 60-200s

Energy resolution: (150 ± 5) eV

Tube voltage: 5kV-50kV

Tube current: 50uA-1000uA

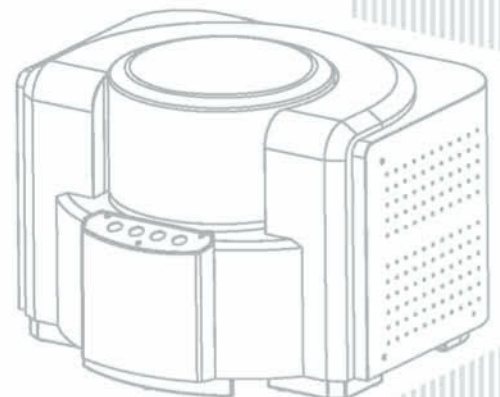

EDX 3600B



Vacuum system- a technological advance

Compared with tradition instruments, this one is more advantageous. It shields against the atmospheric influence and greatly enlarges the measurement scope. By a touch of the finger, the instrument opens and shuts, rises and falls.

The inner structure- a perfect combination of strength and beauty.

The whole steel structure is a guarantee of the strength reliability, while the external appearance owns its smoothness and elegance to plastic material.

Automatic collimator and filter switching- a tradition of intelligence system

This exempts you from the complicated manual operation and its technological charm blooms in the humanity consideration.

Triple safety protection mode

Independent matrix effect correction models

Multi-variable non-linear regression procedure

Arbitrary optional analysis and identification models

**X-ray Fluorescence
Spectrometer**

EDX 3600B

Applications

EDX3600B X-ray spectrometer has been widely used in the iron and steel industry and warmly welcomed by our customers. Some of our customers are:

NO.	Name of the organization	Application
1	Shanxin Hanzhong Steel Co., Ltd.	To test blast furnace slag, pig iron, sinter, pellet, dolomite, bentonite, etc.
2	Xiaojiao Steel Rolling Plant, Fujian Sanming Steel Group Co., Ltd.	To test pig iron, sinter, limestone, blast furnace slag, etc.
3	Daguanshan Mine, Taiyuan Iron & Steel (Group) Co., Ltd.	To test quartz, dolomite, ordinary silicon and special silicon, etc.
4	Tangshan Baoye Group Iron and Steel Co., Ltd.	To test pig iron, blast furnace slag, sinter, iron concentrate fines, fused Magnesia, etc.

Furthermore, EDX3600B is used in metallurgical and mineral industries. Our customers are:

NO.	Name of the organization	Application scope
1	National Museum of China	To test ceramics, ancient pottery, bronze ware or help identify the age and validate their authenticity.
2	Shanxi Heavy Vehicle Group Co., Ltd.	To test iron and steel, screws, alloys and so on. To judge whether they are up to the standard.
3	Zhejiang Zhengtai Electrical Appliance Co., Ltd.	To test alloys, steel, stainless steel, plating things and other ironware.
4	Henan Baige Group Co., Ltd.	To test the components of corundum finished products and control the quality of the production process.
5	Jiangmen Fuyi Magnetic Material Co., Ltd.	To test the mixture ratio of ferrite materials and magnetic materials.
6	Jiangsu Lianyungang Geography Engineering Exploration Institute	To test Niobium and Tantalum ore. or used for mineral inspection and mineral collection.
7	Shandong University of Science and Technology.	Used for teaching and scientific study, for example, minerals and alloys test.

The difference between the application of X-ray analytical instrument EDX3600B and traditional chemical method in iron and steel industry:

The iron and steel industry is a manufacturing industry running on large scale and ceaselessness. Raw materials, accessories and middle-products are required to be quickly tested before the results is used for guiding the production process. For such a characterized industry, rapidness is a must in getting the test result. So the analysis of this industry has two distinct traits: samples are various and the tests are in high speed.

Item	Traditional chemical method	EDX3600 family
Speed	Slow, 10 ~ 30 min.	Quick, 2 ~ 5min.
Analytical result	Greatly influenced by operator, poor repeatability	No operator influence, high precision and repeatability
Labor intensity	High	Low, most automatically done
Elements analyzed	Only one element at a time	Tens of elements at a time
Chemical relativity	Analysis method varies with different sample chemical property	Pure physical method, no relativity with sample chemical property
Cost	High	Low
Skill requirement	High, long-time training	Low, simple training

EDX 3600B

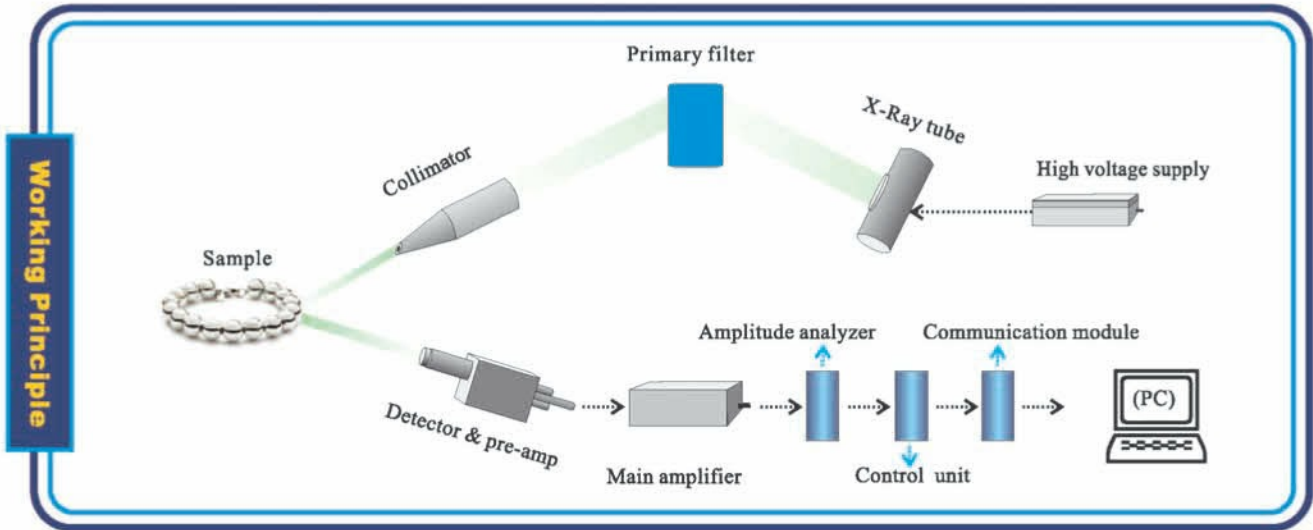

Characteristic X-radiation of element

Each element will emit X-ray at its own energy level when excited. This X-ray is characteristic and called X-ray fluorescence. It is the foundation of analysis.

Scattering

It is the background of spectrum.

Photoelectron

The photoelectron is the foundation of detector. In the sample, the X-ray intensity of every element is expressed as $I_1, I_2, I_3, I_4, I_5 \dots$ respectively. The element content C is the function of X-ray fluorescence intensity I , expressed as following:

$$C = f(I_1, I_2, I_3, I_4, I_5 \dots)$$

This equation is too complicated and can be simplified as:

$$C = K_1 I_1 + K_2 I_2 + K_3 I_3 + K_4 I_4 + K_5 I_5 \dots$$

Where

C is the element content in the sample; $I_1, I_2, I_3, I_4, I_5 \dots$ are X-ray intensity of element respectively; $K_1, K_2, K_3, K_4, K_5 \dots$ are coefficients which can be determined by measuring known standard sample to calibrate.

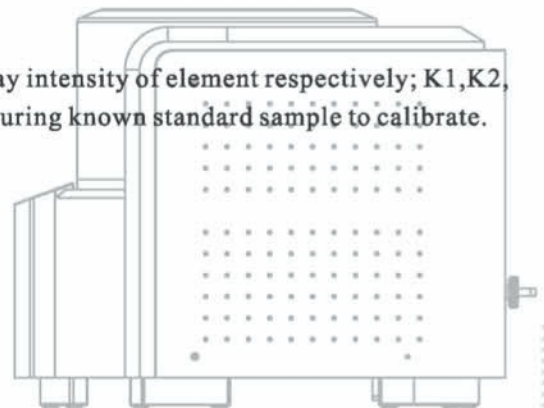

Examples

Cement industry

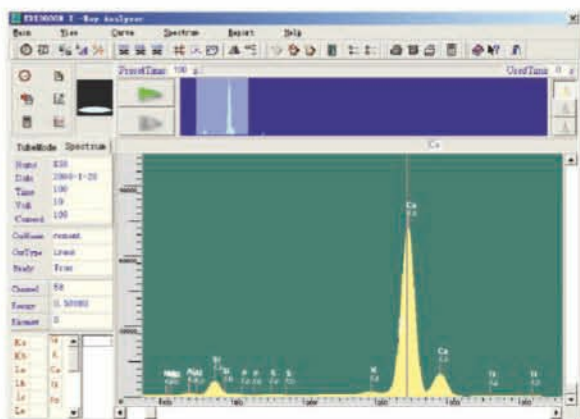

Element	content	Intensity
Na	0.321	01.610
Mg	2.954	99.550
Al	4.042	182.950
Si	14.939	750.010
K	0.593	326.860
Ca	41.094	8114.300
Fe	0.213	62.100

Analytical data of light elements taken by EDX3600B

Times	Elements Results	Ca content	Na content	Mg content	Al content	Si content	K content	Ti content	Fe content
Test1		44.410	0.458	3.563	4.582	10.012	0.344	0.113	3.388
Test2		44.400	0.448	3.460	4.442	9.801	0.352	0.113	3.385
Test3		44.448	0.427	3.480	4.493	9.954	0.347	0.112	3.368
Test4		44.461	0.430	3.652	4.397	9.804	0.349	0.111	3.389
Test5		44.423	0.448	3.608	4.491	9.879	0.342	0.113	3.388
Test6		44.475	0.450	3.534	4.519	9.917	0.347	0.112	3.375
Test7		44.446	0.444	3.782	4.663	9.934	0.351	0.111	3.389
Test8		44.347	0.446	3.729	4.442	10.110	0.350	0.109	3.365
Test9		44.355	0.450	3.560	4.450	10.090	0.352	0.111	3.354
Test10		44.444	0.452	3.581	4.359	10.076	0.350	0.113	3.374
Test11		44.444	0.464	3.554	4.548	9.688	0.351	0.113	3.372
Test12		44.429	0.448	3.655	4.499	9.789	0.352	0.113	3.350
Test13		44.430	0.453	3.717	4.521	10.093	0.350	0.113	3.359
Test14		44.490	0.451	3.779	4.466	10.206	0.348	0.111	3.362
Test15		44.462	0.446	3.679	4.483	10.212	0.348	0.115	3.362
Test16		44.494	0.445	3.445	4.426	10.044	0.355	0.109	3.350
Test17		44.440	0.435	3.720	4.418	10.053	0.348	0.111	3.355
Test18		44.418	0.438	3.640	4.543	10.067	0.354	0.108	3.369
Test19		44.428	0.427	3.705	4.359	10.310	0.350	0.112	3.371
Test20		44.551	0.466	3.646	4.659	10.391	0.350	0.110	3.368
Average value of content		44.44	0.45	3.62	4.49	10.02	0.35	0.11	3.37
Standard deviation of the measurement Sn		0.04	0.01	0.10	0.08	0.18	0.00	0.00	0.01
3s value		0.13	0.03	0.29	0.25	0.53	0.01	0.01	0.04
Relative standard deviation RSD (%)		0.10%	2.34%	2.71%	1.82%	1.76%	0.86%	1.51%	0.38%

$$S_{(n)} = \sqrt{\frac{\sum_{i=1}^n (N_i - \bar{N})^2}{n-1}}$$

$$\bar{N} = \frac{\sum_{i=1}^n N_i}{n}$$

Sn ---Standard deviation after n times of tests
N--times of test

\bar{N} -Average value after n times of tests
RSD can be calculated by using the equation below

$$RSD = \frac{S_{(N)}}{\bar{N}} \times 100\%$$

Sample name: Cement Xs2#

EDX 3600B

Iron and steel industry

Pig iron

Pig iron is the most important middle product in the production process of iron and steel industry. Its quality is directly concerned with the quality of the final product. It determines the usage amount of energy and accessories before it is processed to steel billet. Si, Mn, P and S in the pig iron can also be detected by X-ray fluorescence spectrometer. The test is highly precise.

The spectrum and working curve of real iron test taken by EDX3600B are listed below.

The pig iron spectrum taken by EDX3600B

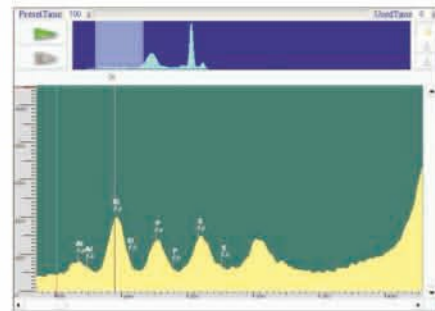

The spectrum figure shows that the spectra line of Si, Mn, P and S are very clear. The sample element measurement can be obtained easily from the spectrum. Moreover, the spectra line of the accessory elements such as Al and Cr are also very clear. They can also be detected at the same time.

Working curve and relative data of Pig iron-Si

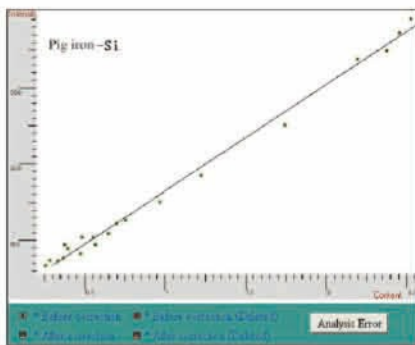

Spectrum name	Content	Intensity
LQ-6	1.16	172.06
13682Q	0.39	89.08
11048Q	2.37	348.8
11051Q	2.45	372.8
11048A	2.19	337.96
11049Q	2.52	391.27
4265-1	0.25	66.77
4265-2	0.28	73.63
1429T	0.46	115.53
14299-1	0.47	82.44
14300-1	0.55	104.26
14300-2	0.69	122.17
14302-2	0.36	76.36
14323-1	0.37	94.35
14351-1	0.33	73.13

The test accuracy of the actual pig iron test

Elements	Si	Mn	P	S
Range of content	0.1~1.0	0.1~1.0	0.05~0.1	00.010~0.10
(SD) Test accuracy	0.02	0.015	0.004	0.002

Sintering ore



During the test of sintering ore, EDX3600B mainly detects the elements like Fe, Ca and Si. The test accuracy is very reliable. It can also detect the accessory elements like Mg, P, S, Cr, Mn and Ti.

The spectrum and working curve of real sintering ore taken by EDX3600B are listed below.

Sintering ore spectrum taken by EDX3600B

A、spectrum of high-alkali sintering ore

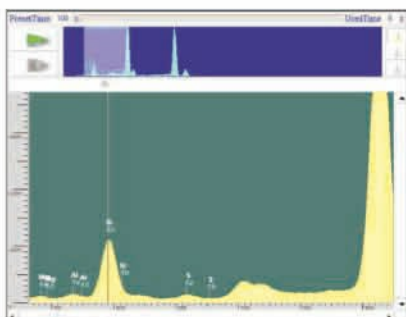

B、Spectrum of low-alkali sintering ore

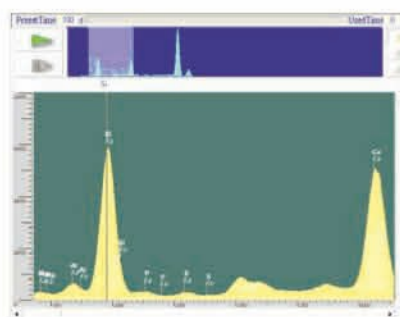

The spectrum figure shows that the spectra line of Fe, Ca and Si are very clear. The sample element measurement can be obtained easily from the spectrum. Moreover, the spectra line of the accessory elements such as Al, K, S, Fe and Mg are also very clear. They can also be detected at the same time.

The working curve of Ca in sintering ore and other relative data

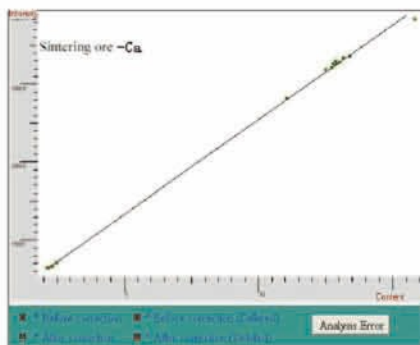

Spectrum name	Content	Intensity
YSBC15704	15.79	3838.38
CS-D8	2.09	647.39
LS-24	13.13	3344.89
LS-22	12.48	3186.29
LSD-10	2.28	661.17
LSD-11	2.46	712.63
S4-23	12.77	3264.87
LS-25	12.99	3283.42
CSD-9	2.16	645.77
LS-23	12.69	3216.76
LS-21	12.84	3295.33
GBW07219A	11.03	2817.66
S4-45	13.38	3366.53

The test accuracy of the actual test of sintering ore

Elements	Ca	Si	Fe
Range of content	5.00~20.00	5.01~15.00	≥50.00
(SD) Test accuracy	≤0.15	≤0.15	≤0.2

EDX 3600B

Ferrosilicon

Ferrosilicon is usually used to test the content of Si, Fe, and Ca. On our instrument, it can test the elements like Al, Ca, Mn, Cr, and Ti with great precision.

Below are the spectrum and working curves in a test of ferrosilicon by EDX3600B

The spectrum of ferrosilicon taken by EDX3600B

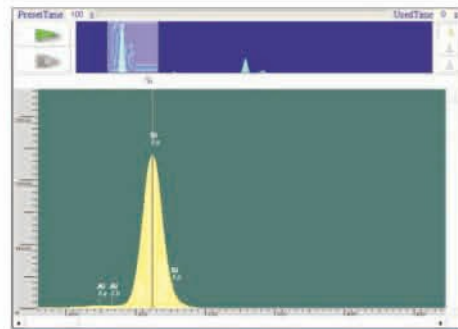

The working curve and relative data of Mn in ferrosilicon

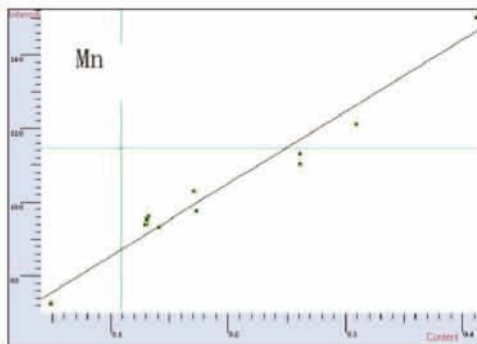

Spectrum name	Content	Intensity
EH0225-1	0.411	150.21
EH0225-2	0.308	121.09
EH0301-4	0.17	102.89
YSBC28604	0.131	96.09
YSBC28607	0.13	96.51
第2001号	0.26	110.34
YSBC28608	0.13	94.36
第2002号	0.26	113.24
EH1913-1	0.128	93.97
EH0301-6	0.14	93.23
GBW01422A	0.172	97.64
YSB14602	0.048	72.52

The accuracy of the actual test of ferrosilicon

Elements	Si	Ca	Fe	Mn
Range of content	≥50.00	0.10~2.00	20.00~50.00	≤0.5
(SD) Test accuracy	≤0.2	≤0.015	≤0.10	0.01

PERIODIC TABLE OF ELEMENTS (Characteristic X-Ray energy table)

Per	IA																	0	
1	1 H 1.008																	2 He 4.008	
		IIA											IIIA	IVA	VA	VIA	VIIA		
2	3 Li 6.94 0.052	4 Be 9.012 0.110											5 B 10.81 0.185	6 C 12.01 0.282	7 N 14.01 0.392	8 O 15.99 0.523	9 F 18.99 0.677	10 Ne 20.17 0.861	
3	11 Na 22.99 1.041	12 Mg 24.31 1.254											13 Al 26.99 1.487	14 Si 28.09 1.740	15 P 30.97 2.015	16 S 32.06 2.307	17 Cl 35.45 2.622	18 Ar 39.94 2.957	
			III B	IV B	V B	VI B	VII B	VIII		I B	II B								
4	19 K 39.1 3.3(2) 3.589	20 Ca 40.08 3.690 4.012 0.341 0.344	21 Sc 44.96 4.088 4.459 0.395 0.399	22 Ti 47.90 4.508 4.931 0.452 0.458	23 V 50.94 4.949 5.427 0.51 0.519	24 Cr 51.99 5.411 5.947 0.571 0.581	25 Mn 54.94 5.895 6.492 0.636 0.647	26 Fe 55.84 6.400 7.059 0.704 0.717	27 Co 58.93 6.925 7.649 0.775 0.790	28 Ni 58.7 7.472 8.265 0.849 0.866	29 Cu 63.54 8.041 8.907 1.009 1.032	30 Zn 65.38 8.631 9.572 1.096 1.032	31 Ga 69.72 9.243 10.26 1.186 1.122	32 Ge 72.5 9.876 10.98 1.186 1.216	33 As 74.92 10.53 11.73 1.317	34 Se 78.9 11.21 12.80 1.419	35 Br 79.90 11.91 13.29 1.48	36 Kr 83.8 12.63 14.12 1.587 1.638	
5	37 Rb 85.47 13.38 14.97 1.694 1.752	38 Sr 87.82 14.14 15.85 1.806 1.872	39 Y 88.91 14.93 16.75 1.922 1.996	40 Zr 91.22 15.75 17.69 2.042 2.124 2.302 1.792	41 Nb 92.91 16.58 18.65 2.166 2.257 2.462 1.902	42 Mo 95.94 17.44 19.63 2.293 2.395 2.623 2.015	43 Tc #(99) 18.33 20.65 2.424 2.538 2.792 2.122	44 Ru 101.0 19.24 21.69 2.558 2.683 2.964 2.252	45 Rh 102.9 20.17 22.76 2.696 2.834 3.144 2.376	46 Pd 106.4 21.12 23.86 2.838 2.990 3.328 2.503	47 Ag 107.9 22.10 24.99 2.984 3.151 3.519 2.633	48 Cd 112.4 23.11 26.14 3.133 3.316 3.716 2.767	49 In 114.8 24.14 27.38 3.287 3.487 3.92 2.904	50 Sn 118.6 25.19 28.60 3.444 3.662 4.131 3.044	51 Sb 121.7 26.27 29.85 3.605 3.843 4.347 3.188	52 Te 127.6 27.38 31.13 3.769 4.029 4.570 3.335	53 I 126.9 28.51 32.44 3.937 4.220 4.800 3.484	54 Xe 131.3 29.67 33.78 4.111 4.422 5.036 3.636	
6	55 Cs 132.9 20.85 35.15 4.286 4.620 5.286 3.794	56 Ba 137.3 32.07 36.55 4.467 4.828 5.531 3.953	Ln	72 Hf 178.4 55.38 63.56 7.898 9.021 10.51 6.958	73 Ta 180.9 57.11 65.56 8.145 9.341 10.81 7.172	74 W 183.8 58.86 67.59 8.396 9.670 11.28 7.386	75 Re 186.2 60.66 69.66 8.651 10.01 11.68 7.602	76 Os 190.2 62.48 71.78 8.910 10.35 12.09 7.821	77 Ir 192.2 64.35 73.93 9.173 10.71 12.51 8.040	78 Pt 195.0 66.25 76.13 9.441 11.07 12.94 8.267	79 Au 197.0 68.19 78.37 9.711 11.44 13.38 8.493	80 Hg 200.5 70.16 80.66 9.987 11.82 13.82 8.720	81 Tl 204.3 72.18 82.99 10.27 12.21 14.28 8.952	82 Pb 207.2 74.23 85.36 10.55 12.61 14.76 9.183	83 Bi 208.9 76.32 87.77 10.84 13.02 15.24 9.419	84 Po #(209) 78.46 90.24 11.13 13.44 15.74 9.662	85 At #(210) 80.64 92.75 11.42 13.87 16.25	86 Rn #(222) 82.86 95.32 11.72 14.32 16.77	
7	87 Fr # (223) 82.12 97.93 12.03 14.77	88 Ra # 226.0 87.44 100.6 12.34 15.23 17.8 10.60	An																

- Alkali Metals
- Non-Metal
- Transitional element
- Halogen
- Lanthanoids
- Actinides
- Alkaline earth
- Rare gases
- Main group metal

Mark 1: #Radioactive Elements *Man Made Elements
2: All the Numbers are ordered one by one in this way, Atomic Number
Element Symbol, Atomic Weight, K α , K β ,L α ,L β ,L γ ,Lε

Ln	57 La	58 Ce	59 Pr	60 Nd	61 Pm	62 Sm	63 Eu	64 Gd	65 Tb	66 Dy	67 Ho	68 Er	69 Tm	70 Yb	71 Lu
	138.9	140.1	140.9	144.2	#(147)	150.4	152.0	157.2	158.9	162.5	164.9	167.2	168.9	173.0	175.0
	33.30	34.57	35.86	37.19	38.54	39.91	41.32	42.76	44.23	45.73	47.26	48.82	50.41	52.04	53.59
	37.99	39.45	40.95	42.48	44.05	45.65	47.28	48.95	50.65	52.38	54.16	55.96	57.81	59.69	61.61
	4.651	4.840	5.034	5.230	5.431	5.636	5.846	6.059	6.275	6.495	6.720	6.948	7.181	7.414	7.654
	5.043	5.262	5.489	5.722	5.956	6.206	6.456	6.714	6.979	7.249	7.528	7.810	8.103	8.401	8.708
An	89 Ac	90 Th	91 Pa	92 U	93 Np	94 Pu	95 Am	96 Cm	97 Bk	98 Cf	99 Es	100 Fm			
	#	#	#	#	#	#	#*	#*	#*	#*	#*	#*			
	(227)	(232)	231.0	238.0	(237)	(244)	(243)	(247)	(247)	(251)	(252)	(257)			
	89.79	92.19	94.64	97.14	99.69	102.3	104.9	107.7	110.5	113.3	116.2	119.2			
	103.3	106.1	108.9	111.8	114.7	117.7	120.8	123.9	127.1	130.4	133.7	137.2			
	12.65	12.97	13.29	13.61	13.95	14.28	14.62	14.96	15.31	15.66	16.02	16.38			

Skyray - We Only Make Precision Instruments
Spectroscopy - Chromatography - Mass Spectroscopy

Optech Solutions

Riverside Court, Beaufort Park, Chepstow NP16 5UH, UK

Tel: +44 (0)1291 418148

Website: www.optechsolutions.co.uk

E-mail: info@optechsolutions.co.uk