

TECHNICAL

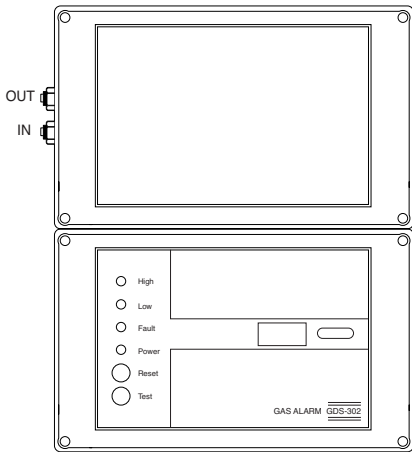

- T1 - Alarm delay - 10 secs
- T2 - Alarm delay - 30 secs
- T1 & T2 Alarm delay - 10 minutes
- LL - Low/Low alarm
- O₂ - Oxygen sensor
- RES - Manual/Auto Reset
- TP1 - OV
- TP2 + } 4~20mA output mV=mA
- TP3 - }
- TP4 + } DPM span 0.5v=F.S.D
- TP5 - }
- TP6 and TP1 sensor supply mV = mA

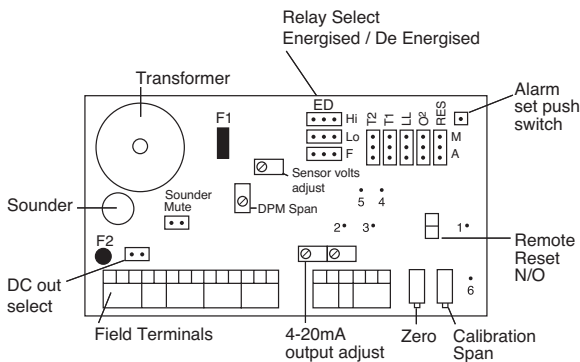

1	2	3	4	5	6	7	8	9	10	11	12	13	14	15	16	17	18	19	20	
E	L	N	+	-	Nc	C	No	Nc	C	No	Nc	C	No	-	+	E	P	Y	W	+
Mains			IN/OUT	DC	Low	Alarm	High	Alarm						4-20mA			Sensor			

Power supply	230/115vAC or 24vDC ± 15% The two voltages may be used simultaneously (standby batteries)
Frequency	50/60Hz
Consumption	10 watts
Indicators	Power - Green L.E.D. Alarms - Low/High - Red L.E.D. Fault - Amber L.E.D.
Outputs	Low alarm relay - S.P.C.O High alarm relay - S.P.C.O Fault alarm relay - S.P.C.O Relays rated 5A/230AC ND or NE pre set normally de energised Analogue 4-20mA/1-5v 24vDC - 100mA max (Auxiliary equipment supply)
Audible Alarm	Gas - Fault alarm
Reset Switch	Auto or Manual - pre set manual
Test Switch	Used to check alarm indicators, sounder and relay action
Inhibit	Isolation of alarm relays during service
Protection	IP65
Environmental	Ambient temperature -5 to 45°C Storage temperature +10 to 60°C Humidity range 0 - 90 RH
Cable Entry	Rear, side, top, bottom
Sample Tube	6mm OD 4mm ID Max. length 4m

INSTALLATION

The unit should be mounted in a position which is accessible and in the field of vision.

- Mains should be from a fused supply.

The positioning of the sample tube depends upon the type of gas to be monitored and its density with respect to air.

- **Heavy gases** (LPG, Propane, Butane, Refrigerant Gases) - Locate at 15 to 20 cm from the floor. Lighter Gases (Methane, Natural Gas, Town Gas) - Locate at 5 to 10cm from the ceiling
- **Carbon Monoxide** - Locate at 1.5 to 2 metres from the floor.

Where appropriate the sample tube nozzle should be positioned directly in the target area.

All equipment should be mounted away from direct heat.

TESTING

The unit may be electrically tested by pressing the test pad for 15 seconds after which the alarm indicators and sounder will activate intermittently, maintaining pressure on the pad for a further 15 seconds will result in constant sounder / indicators and activation of alarm relays.

During servicing alarm relays may be isolated by pressing the reset pad for 15 seconds after which the fault indicator will come on indicating inhibit mode, to remove inhibit press the reset pad for 15 seconds the fault indicator will turn off.

To ensure that the system responds correctly to the presence of gas, the sensor should be exposed to test gas. It is advisable to carry out this test at six monthly intervals.

SETTING UP

Having terminated all cables switch on power and allow 3 minutes warm up time. Using a small terminal screwdriver and with the sensor sampling in clean air adjust the zero potentiometer until the digital meter reads zero for toxic/flammable gases or for oxygen adjust the calibration potentiometer until the meter reads 20.8, the system is now set up.

Alarm levels are factory set but may be re-adjusted as follows:-

- 1 For toxic/flammable gases zero the instrument in clean air using the zero potentiometer (for ambient oxygen monitoring the meter should be adjusted to read 20.8 using the calibration potentiometer).
- 2 Press the alarm set switch for approximately 5 seconds the sounder will bleep and the low alarm indicator will come on, the green power indicator will turn off, release the alarm switch.
- 3 Using the zero potentiometer adjust the digital display for the required low trip level reading, press the alarm set switch until the high alarm indicator comes on, release the alarm set switch.
- 4 Adjust the digital display to read the required high trip level reading and again press the alarm set switch, both alarm indicators will come on.
- 5 Zero digital display (toxic/flammable) or 20.8 for oxygen and press alarm set switch, alarm indicators will turn off and the green power indicator will turn on.

OPERATION

On power up the green power indicator will flash for 60 seconds indicating that the sensors are stabilising, during this period all alarms are held in the off condition.

After the stabilisation period any gas detected by the sensor will be indicated on the digital display with any alarm level being exceeded resulting in the sounder and appropriate red L.E.D and relay activating.

Pressing the reset pad will result in the sounder being silenced, alarm indicators and relays may only be reset when the indicated gas level has reduced to below that of the alarm trip points.