

TECHNICAL

- Input Voltage** 12~30v DC - 24v nominal
- Current** Nominal 160mA
- Output Standard** Analogue 4- 20 ma (250 ohms max) - 3 wire (source mode – standard)
Option 1 ~ 5v output – Link - LK1
- Sensor Cable** 3 core 1.5mm screened, maximum cable loop resistance 20ohms
- Alarm Relay Board** Relay contacts S.P.C.O. rated 1A/24vDC 0.5A/120vAC option 5A/230vAC
- Options** Trip Indicator LED - trip point selectable 10% to full scale
(safe area board only) Fire Alarm panel signalling - Remove LK1
- Full Board Options** Logic output - JP1 position L and end of line link JP2 – normally set at A (analogue)
(safe area board only) On board sounder
Auxiliary output DC volts - standard - as input volts 24vDC
(selection by fixed voltage regulator U5 - 5, 12, 15 volts)
DPM - gas readout display - (DPMZ and DPMS potentiometers used only for DPM setting)

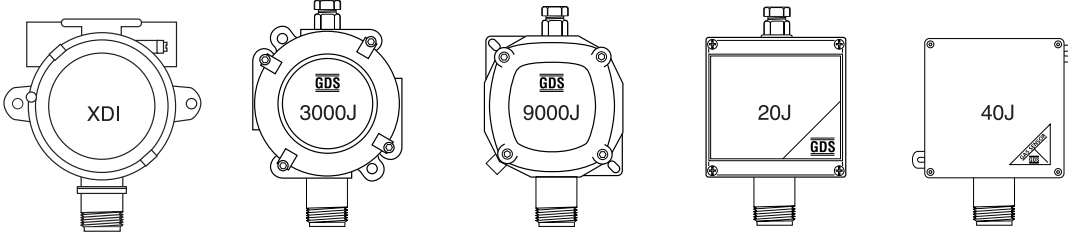

INSTALLATION

For hazardous area equipment see specific instructions supplied with the equipment, or visit our website for technical information. Siting of the equipment should be chosen with regard to the following points:

- 1) Away from sources of heat and with room for adequate air circulation.
- 2) Within easy reach for operating and maintenance personnel.
- 3) Connecting cables to be electrically shielded, i.e. M.I.C.C., steel wire armoured, screened cable or steel conduit.
- 4) For sensor location see our website.

Note: Sensor cables should not be run in the same ducting as power cables.

SET UP

1. Having powered up allow 5 minutes for the sensor to stabilise.
2. The sensor current/voltage should be set by connecting a voltmeter (mV range) across TP3/TP4 and adjusting the sensor voltage potentiometer (10 turn) until the required voltage reading is obtained – 170mV (mV meter reading = mA sensor current) CAUTION – DO NOT EXCEED 250mV (mA).
3. Zero the card in clean air by adjustment of the potentiometer marked zero until the GREEN ON/Zero LED just turns from GREEN/RED to GREEN. (At this point the output will = 4mA). If you require to check this, connect a digital meter (mV relay) to the test pins marked TP1 and TP2, if adjustment is required adjust the 4mA potentiometer (4mV = 4mA).

4. Where a digital panel meter is fitted to the CV card the reading may be adjusted by the DPM Z potentiometer (zero).

CALIBRATION

With the digital meter connected to the test pins TP1 and TP2 and a reading of (4mV clean air) apply test gas and wait until a maximum reading is obtained, if necessary adjust the 20mA potentiometer for the required mV reading for the calibration gas being used.

Where a Digital panel meter is fitted the display may be adjusted by using the DPM S potentiometer (span).

ADDITIONAL RELAY BOARD ALARM TRIP POINT ADJUSTMENT

This level will normally be set at 20% of the range reading i.e. 7.2mA.

1. Connect the DVM as above, using the zero potentiometer adjust for the required trip level (mV)
2. Adjust the alarm level potentiometer until the relay just changes state.
3. Using the zero potentiometer re-adjust the DVM to 4mV.

The above adjustment may be carried out in house by connecting the CV transmitter directly to a DC power supply.

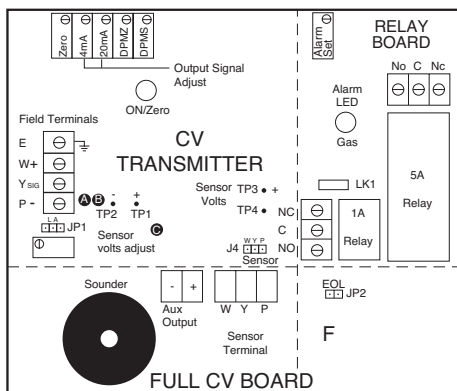

SAFE AREA SENSOR BOARD

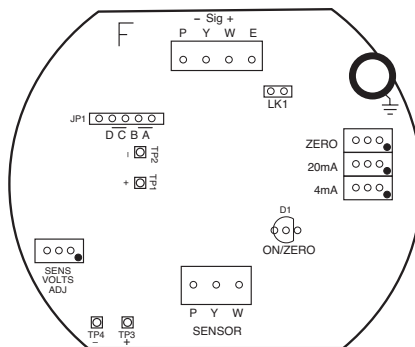

EExd SENSOR BOARD

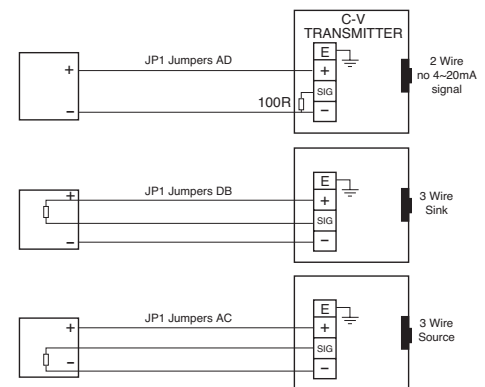

GDS Technologies Ltd

Fusion Point, Ash Lane
Garforth, Leeds LS25 2GA
Tel +44 (0)113 286 0166
Fax +44 (0)113 287 8178
sales@gds-technologies.co.uk
www.gds-technologies.co.uk

