

XDI-F1

HAZARDOUS AREA GAS DETECTOR



Specification Sheet Ref C744

JUNCTION BOX

Type	- XDI
Flame proof	
Certification	ATEX – EExd IIC T6 T85°C II2GD Certificate No. FTZU-06ATEX0296X
Lid/Base	Thread type with lock screw - 2mm
Ingress Protection	IP66
Material	Body & Cover aluminium alloy Option – stainless steel
Finish	Standard – chemically resistant epoxy paint Option – marine grade finish
Entries	Two entry 20mm 1.5 pitch standard alternative 25mm – ¼ NPT
Mounting Detail	Two M5 (126mm CRS)
Weight	XDI-1.2Kg XDI-win-1.5kg
Approx. Dimensions	XDI-115mm W x 108mm H XDI-win -115mm W x 130mm H



DETECTOR HEAD

Type	- F1
Data Sheet	Ref C105
Classification	ATEX – EExd IIC T6 T85°C (T3, T4, T5 options) II2GD
Certificate	Sira-03ATEX1176X/SIR 06.0016X
Ingress Protection	IP63 + water shield IP65
Sensor Inserts	Infra Red Electrochemical Pellistor catalytic Thermal Conductivity Semiconductor
Mounting Thread	20mm 1.5mm Pitch – options 25mm, ¼ NPT
Accessory Mount	Fixing thread 33.3mm 1.25 pitch
Material	Stainless Steel 316 S16
Weight	165gms
Dimensions	Body 32mm long 33mm dia.
Accessories	003-010 Collection Cone & Universal Fitting 003-020 Universal Fitting (test gas applicator/spray deflector) 003-035 Water shield 008-311 Flow adaptor 003-090 Duct mounting kit 003-031 Filters - particulate

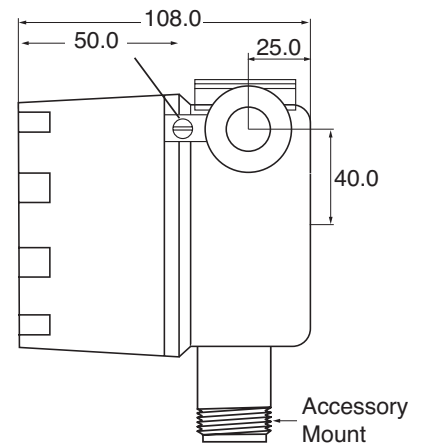
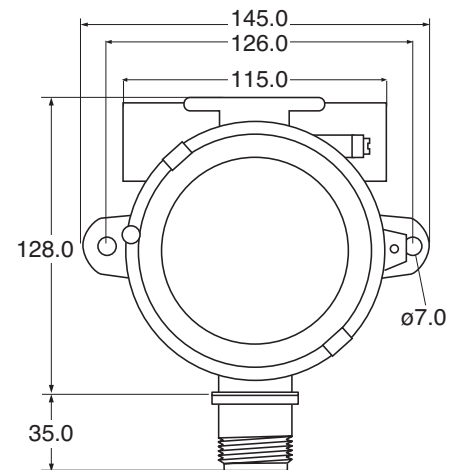

GDS Technologies Ltd

Fusion Point, Ash Lane
Garforth, Leeds LS25 2GA
Tel +44 (0)113 286 0166
Fax +44 (0)113 287 8178
sales@gds-technologies.co.uk
www.gds-technologies.co.uk