

- **Rugged and reliable**
- **Explosion proof**
- **Automatic diagnostic system surveillance**
- **Harsh environmental use**
- **Engineered for ease of maintenance and reduced running costs**

The GDS Red Line XDI sensor uses proven non-dispersive single beam dual-wave length infrared principles to detect and monitor the presence of gases. This non-poisoning sensing technique relies on the target gas having a unique well-defined absorption signature.

This is used to identify the presence of the target gas and is highly specific. Using a suitable infrared source, an analysis of the optical absorption through the gas allows the concentration of the target gas to be determined.

All sensor driving is internal to the transmitter and full fault monitoring of the sensor and transmitter is continuous.

The sensor signal is used to provide a linear output in voltage and 4-20mA format, calibration is by means of 4 and 20mA span potentiometers with the signal being internally linearised without the need for user adjustments.

This information relates to the device operating continuously.
The device may be calibrated for other gases.

Hydrocarbon Sensor

Operation – continuous diffusion	NDIR (dual wave-length)
Measuring Range – Standard	0~100% LEL
Others available	
Accuracy	± 5% F.S.D
Warm up time to zero	< 20 seconds
Response time to target gas T90	< 35 seconds
Long term zero drift	± 5% F.S.D

Internal indicators are included for designating the transmitter status.

These include:-

- Device Active
- Indication of sensor source pulsing
- Indication of the calibration mode
- Fault diagnostics

The 4~20mA output provides a fault indication by reducing the output to below 3mA, with the recovery from fault condition being automatic.

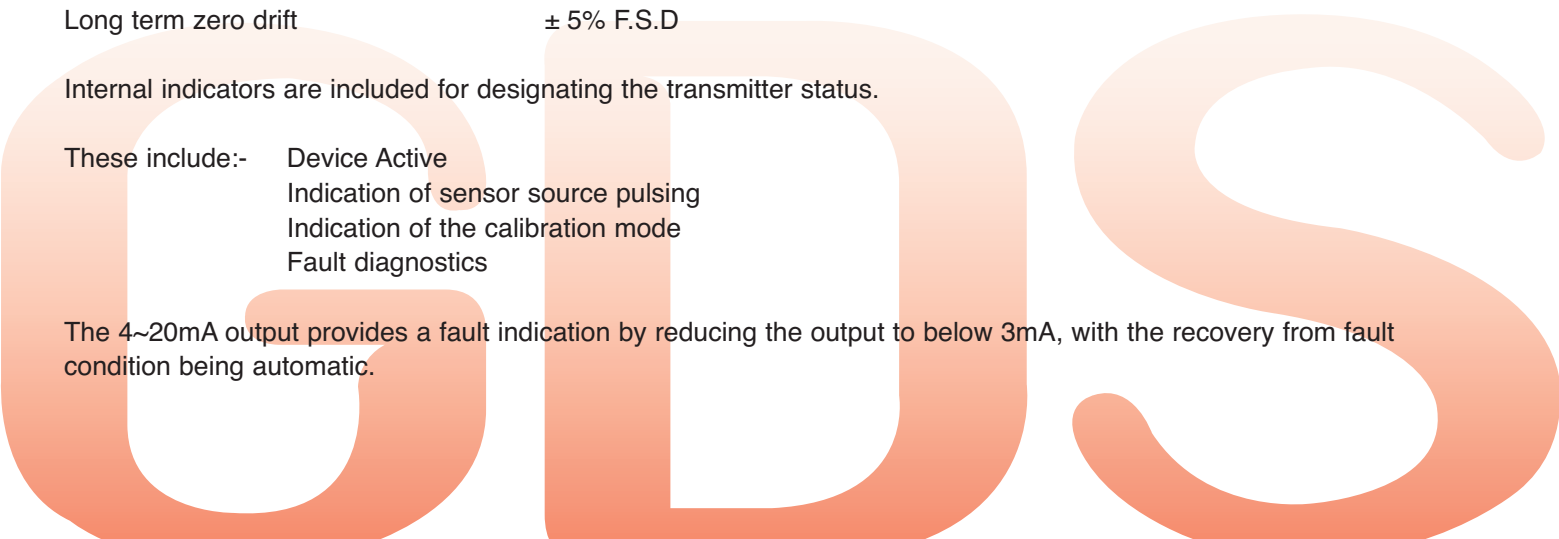

Input voltage – 3 wire device (polarity protected)	12 to 35V DC – 24v DC nominal
Output	4~20mA (link selectable as sink or source)
Voltage output 1~5V, maximum current draw	5mA
Maximum current consumption	130mA
Resolution	0.15% of span
Maximum loop resistance in source mode	250R
Output resolution	0.02mA
Maximum offset drift	± 20uA
Over-range output	21.3mA (typical)
Fail signal	4~20mA reduced to 3mA
Fail indicator	Open collector output to 0V

Mechanical Data

Certification	ATEX – EExd IIC T6 112GD F1 Sensor – SCS Cert No 03ATEX1176X ATEX – XDI Enclosure FTZU– Cert No 06ATEX0296X
Replaceable plug in sensor	In-situ
Sensor accessory mounting thread	33mm ø 1.25 pitch – 6 full threads
Enclosure – Type XDI	Aluminium alloy - optional stainless steel
Gas Sensor – Type F1	Stainless steel – 316 S16
Weight	3.95Kg
Cable Entry	One – 20 mm 1.5 pitch Options 25 mm - ¼ NPT
Mounting Detail	Two M5 (126 mm CRS)
Approximate dimensions-terminal enclosure	126 mm dia. 83 mm deep
On Board Indicators: -	
Green LED	System healthy
Three red LED's	System diagnostics

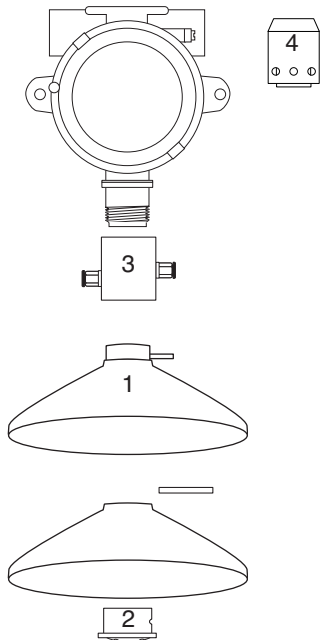

IP53 + Water Shield IP65
Operating Conditions
 0 ~100% RH (non-condensing)
 -10 ~ +50°C
Storage Conditions
 0~100% RH (non-condensing)
 -20 ~ +60°C

- Accessories:-
- 1 - 003-010 Collector Cone + universal fitting
 - 2 – 003-020 Test Gas Applicator
 - 3 – 008-311 Flow Block
 - 4 – 003-035 Water Shield
 - 5 – 003-090 Duct Mount Kit