

TECHNICAL

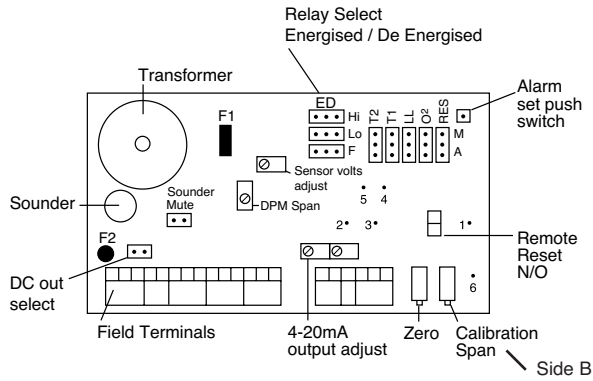

1	2	3	4	5	6	7	8	9	10	11	12	13	14	15	16	17	18	19	20		
E	L	N	+	-	Nc	C	No	Nc	C	No	Nc	C	No	Fault	-	+	E	P	Y	W	+
Mains in				IN/OUT DC		Low Alarm		High Alarm						4-20mA		Sensor					

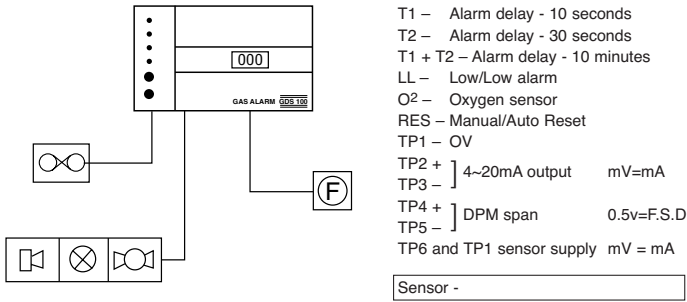
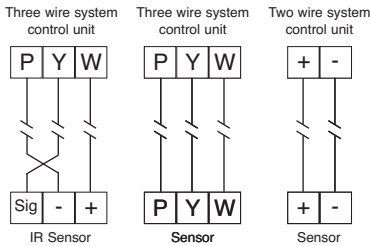

Power supply	230/115vAC or 24vDC ± 15% The two voltages may be used simultaneously (standby batteries)
Frequency	50/60Hz
Consumption	4 watts
Sensor cable	3 core 1.5mm ² screened - 1.5km
Indicators	Power - Green L.E.D. Alarms - Low/High - Red L.E.D. Fault - Amber L.E.D.
Outputs	Low alarm relay - S.P.C.O High alarm relay - S.P.C.O Fault alarm relay - S.P.C.O Relays rated 5A/230AC ND or NE pre set normally de energised (non inductive load only) Analogue 4-20mA/1-5v 24vDC - 100mA max (Auxiliary equipment supply)
Audible Alarm	Gas - Fault alarm
Reset Switch	Auto or Manual - pre set manual
Test Switch	Used to check alarm indicators, sounder and relay action
Inhibit	Isolation of alarm relays during service
Protection	IP65
Environmental	Ambient temperature -5 to 45° C Storage temperature +10 to 60° C Humidity range 0 - 90 RH
Mounting	Wall or panel mount
Cable Entry	Rear, side, top, bottom

INSTALLATION

Control Unit: The control unit should be mounted in a position which is accessible and in the field of vision. • Mains should be from a fused supply.

Sensors: The positioning of sensors depends upon the type of gas to be monitored and its density with respect to air. • Heavy gases (LPG, Propane, Butane, Refrigerant Gases) - Locate at 15 to 20 cm from the floor. Lighter Gases (Methane, Natural Gas, Town Gas) - Locate at 5 to 10cm from the ceiling • Carbon Monoxide - Locate at 1.5 to 2 metres from the floor. All equipment should be mounted away from direct heat.

TESTING

The unit may be electrically tested by pressing the test pad for 15 seconds after which the alarm indicators and sounder will activate intermittently, maintaining pressure on the pad for a further 15 seconds will result in constant sounder / indicators and activation of alarm relays. During servicing alarm relays may be isolated by pressing the reset pad for 15 seconds after which the fault indicator will come on indicating inhibit mode, to remove inhibit press the reset pad for 15 seconds the fault indicator will turn off. To ensure that the system responds correctly to the presence of gas, the sensor should be exposed to test gas. It is advisable to carry out this test at six monthly intervals.

SETTING UP

Having terminated all cables switch on power and allow 3 minutes warm up time. Using a small terminal screwdriver and with the sensor in clean air adjust the zero potentiometer until the digital meter reads zero for toxic/flamable gases or for oxygen adjust the calibration potentiometer until the meter reads 20.8, the system is now set up.

Alarm levels are factory set but may be re-adjusted as follows:-

- 1 For toxic/flamable gases zero the instrument in clean air using the zero potentiometer (for ambient oxygen monitoring the meter should be adjusted to read 20.8 using the calibration potentiometer).
- 2 Press the alarm set switch for approximately 5 seconds the sounder will bleep and the low alarm indicator will come on, the green power indicator will turn off, release the alarm switch.
- 3 Using the zero potentiometer adjust the digital display for the required low trip level reading, press the alarm set switch until the high alarm indicator comes on, release the alarm set switch.
- 4 Adjust the digital display to read the required high trip level reading and again press the alarm set switch, both alarm indicators will come on.
- 5 Zero digital display (toxic/flamable) or 20.8 for oxygen and press alarm set switch, alarm indicators will turn off and the green power indicator will turn on.
- 6 Sensor volts/current may be adjusted by connecting a digital voltmeter across TP1 and TP6 and adjusting the sensor volts potentiometer (mV reading = sensor current mA)

OPERATION

On power up the green power indicator will flash for 60 seconds indicating that the sensors are stabilising, during this period all alarms are held in the off condition. After the stabilisation period any gas detected by the sensor will be indicated on the digital display with any alarm level being exceeded resulting in the sounder and appropriate red L.E.D and relay activating. Pressing the reset pad will result in the sounder being silenced, alarm indicators and relays may only be reset when the indicated gas level has reduced to below that of the alarm trip points.

This document is non contractual and the equipment specification and detail may be modified at any time without prior notice.

Action to be taken if the apparatus alarm sounds:-

- a Extinguish all naked flames, including all smoking materials.
- b Turn off all gas appliances.
- c Do not switch on or off any electrical lights or appliances.
- d Turn off the gas supply at the gas emergency control and/or (with L.P.G supply) the storage tank.
- e Open doors and windows to increase ventilation.

If the alarm continues to operate, even after an alarm re-setting action where appropriate, and the cause of the leak is not apparent and/or cannot be corrected, vacate the premises and immediately notify the gas supplier and/or the gas emergency 24 hour service in order that the installation may be tested and made safe and any necessary repair carried out.

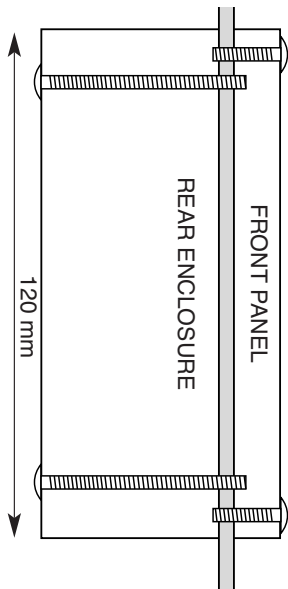
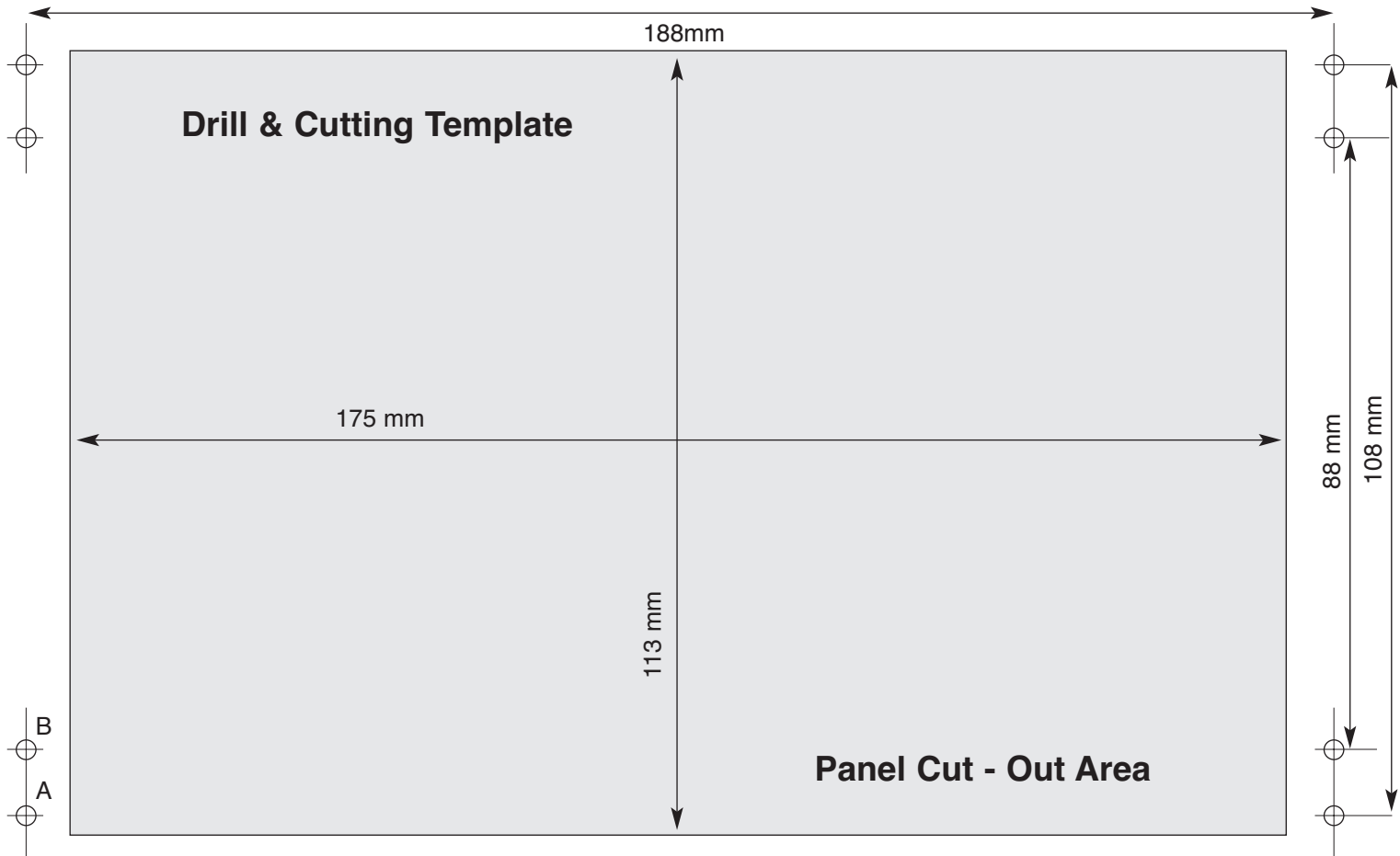

For front panel mounting

drill holes A x4 - 3mm, mount using No.6 20mm self tapping screws

Should the rear enclosure be required

drill holes B x4 - 3.5mm, mount using No.8 50mm self tapping screws