

HAZARDOUS AREA GAS SENSOR

- Installation:** The enclosure must be fixed into position using the external fixing lugs provided. Under no circumstances must the enclosure be supported by way of any cable entry device. The gasket must be secured between the body and the cover. It is important that the cover is securely fitted to the body of the enclosure. All cover fixing screws must be tightened down to 3.5Nm.
- Special conditions for safe use:** (x) The unit should not be used as a safety related device in accordance with directive 94/9/EC.
- T Ratings:** The enclosure may be approved for installation in various ambient temperatures. The marking on the label on the cover must comply with the ambient temperature into which the enclosure is being installed.
- Earthing:** The enclosure is fitted with a brass M6 hexagon headed external earth connection; a suitable ring type terminal lug must be used to secure the earth conductor.
- Maintenance:** Periodic inspection of this enclosure is necessary, refer to EN 60079-17 Clause 4.3 for guidance.
- The enclosure is intended for use under normal industrial conditions and must not be installed in an area where extreme vibration may occur.
- This apparatus has been produced for use in a potentially explosive atmosphere.

- Before it is installed you must be aware of the requirements of BSEN60079 and BSEN50014.
- All unused terminals must be fully tightened down prior to making live.
 - Do not open the Junction Box or remove the F1 sensor end cap when a hazardous gas atmosphere is present.
 - Before removing the end cap of the F1 sensor disconnect the power to the apparatus and wait 3 minutes allowing the sensor elements to cool.
 - The sensor end cap must be fully screwed into the body and the lock screw firmly tightened.
 - All cable entries should be made using suitably certified glands.
 - All unused gland ports should be sealed using appropriate certified stopping plugs.
 - Caution: The installation of this product must be carried out by suitably trained and qualified personnel only. We will not accept responsibility for any damage, injury or any form of loss due to products not being installed or used in strict accordance with these instructions. If in doubt, please contact GDS.**
 - To maintain the certification, only manufacturers supplied spare parts should be used.

Type:	9000 – F1 Detector Head
Notified Body:	SIRA Certification Services, Chester UK CH4 9JN
QA Notification:	SIRA 00ATEXM071
Certification:	Terminal Enclosure - EExde II(T6) T85°C IIGD Tamb -20°C to 35°C
SCS Cert No:	03ATEX1168X
Certification:	F1 Gas Sensor EExd IIC (T6) T85°C II 2GD Tamb -20°C to 35°C
SCS Cert No:	03ATEX1176X
IP Rating:	9000 Junction Box IP66 F1 Sensor IP63 + Water Shield IP65
Entries:	Standard - 20mm 1.5 pitch - options
Weight:	0.9Kg
Approx Dimensions:	JB: 122mm 76mm F1 Sensor: 33mm 33mm
Fixing:	Two M5 (147 CRS @ 45°)

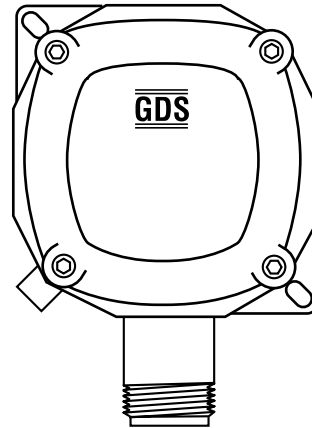

C480C
045-A1

GDS Technologies Ltd declare under our sole responsibility that the product conforms with the relevant provisions of directive 94/9/EC of 23 March 1994.

HAZARDOUS AREA GAS SENSOR

- Installation:** The enclosure must be fixed into position using the external fixing lugs provided. Under no circumstances must the enclosure be supported by way of any cable entry device. The gasket must be secured between the body and the cover. It is important that the cover is securely fitted to the body of the enclosure. All cover fixing screws must be tightened down to 3.5Nm.
- Special conditions for safe use:** (x) The unit should not be used as a safety related device in accordance with directive 94/9/EC.
- T Ratings:** The enclosure may be approved for installation in various ambient temperatures. The marking on the label on the cover must comply with the ambient temperature into which the enclosure is being installed.
- Earthing:** The enclosure is fitted with a brass M6 hexagon headed external earth connection; a suitable ring type terminal lug must be used to secure the earth conductor.
- Maintenance:** Periodic inspection of this enclosure is necessary, refer to EN 60079-17 Clause 4.3 for guidance.
- The enclosure is intended for use under normal industrial conditions and must not be installed in an area where extreme vibration may occur.
- This apparatus has been produced for use in a potentially explosive atmosphere.

- Before it is installed you must be aware of the requirements of BSEN60079 and BSEN50014.
- All unused terminals must be fully tightened down prior to making live.
 - Do not open the Junction Box or remove the F1 sensor end cap when a hazardous gas atmosphere is present.
 - Before removing the end cap of the F1 sensor disconnect the power to the apparatus and wait 3 minutes allowing the sensor elements to cool.
 - The sensor end cap must be fully screwed into the body and the lock screw firmly tightened.
 - All cable entries should be made using suitably certified glands.
 - All unused gland ports should be sealed using appropriate certified stopping plugs.
 - Caution: The installation of this product must be carried out by suitably trained and qualified personnel only. We will not accept responsibility for any damage, injury or any form of loss due to products not being installed or used in strict accordance with these instructions. If in doubt, please contact GDS.**
 - To maintain the certification, only manufacturers supplied spare parts should be used.

Type:	9000 – F1 Detector Head
Notified Body:	SIRA Certification Services, Chester UK CH4 9JN
QA Notification:	SIRA 00ATEXM071
Certification:	Terminal Enclosure - EExde II(T6) T85°C IIGD Tamb -20°C to 35°C
SCS Cert No:	03ATEX1168X
Certification:	F1 Gas Sensor EExd IIC (T6) T85°C II 2GD Tamb -20°C to 35°C
SCS Cert No:	03ATEX1176X
IP Rating:	9000 Junction Box IP66 F1 Sensor IP63 + Water Shield IP65
Entries:	Standard - 20mm 1.5 pitch - options
Weight:	0.9Kg
Approx Dimensions:	JB: 122mm 76mm F1 Sensor: 33mm 33mm
Fixing:	Two M5 (147 CRS @ 45°)

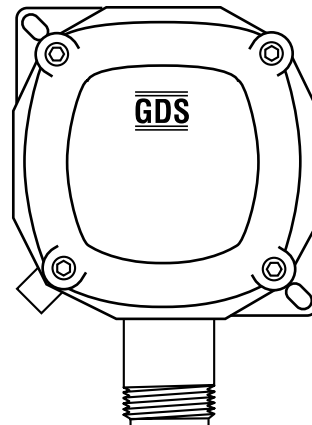

C480C
045-A1

GDS Technologies Ltd declare under our sole responsibility that the product conforms with the relevant provisions of directive 94/9/EC of 23 March 1994.