

Differential pressure transmitter in cleanroom-conform panel design

testo

SPECIFICATIONS

testo 6383



The differential pressure transmitter testo 6383 was developed specially for monitoring low differential pressures in the measuring range from 10 Pa to 10 hPa. In cleanroom technology, the maintenance of positive pressure prevents the entry of contaminated air in critical zones. Thanks to an optional internal or external probe from the probe series 6610, the additional recording of humidity and temperature with one instrument is also possible.

The testo 6383 is particularly outstanding thanks to the automatic zero-point adjustment which ensures high accuracy and long-term stability.

The integrated self-monitoring and early warning function also guarantees the operator high system availability.

Areas of application:

- Monitoring positive and negative pressure in cleanrooms, operating theatres and isolation rooms
- Optional monitoring of humidity and temperature in cleanrooms

testo

SPECIFICATIONS

testo 6383

- Measurement of differential pressure; optional: humidity and temperature
- Automatic zero-point adjustment guarantees high, temperature-independent accuracy and long-term stability
- Low measurement range up to 10 Pa ensures highest precision at lowest pressures
- Flat housing allows flush surface integration in the cleanroom wall
- Display with multi-language operating menu and optical alarm display
- Ethernet, relay and analog outputs allow optimum integration into individual automation systems
- Self-monitoring of the transmitter and early warning function guarantee high system availability
- The P2A software for parameterization, adjustment and analysis saves time and costs in commissioning and maintenance
- Scalability of ± 50 percent of the measuring range final value and free scalability within the measuring range
- Configurable alarm management with adjustable response delay and alarm acknowledgement



Differential pressure transmitter in cleanroom-conform panel design

Technical data

Parameters		
Differential pressure		
Measuring range	0 to 10 Pa 0 to 50 Pa 0 to 100 Pa 0 to 500 Pa 0 to 10 hPa	-10 to +10 Pa -50 to +50 Pa -100 to +100 Pa -500 to +500 Pa -10 to +10 hPa
Measurement uncertainty*	±0.3% of measurement range final value ±0.3 Pa Temperature gain drift: 0.02% of measuring range per Kelvin deviation from nominal temperature 22 °C Zero point drift: 0% (thanks to cyclic zero-point adjustment)	
Selectable units	Differential pressure in Pa, hPa, kPa, mbar, bar, mmH ₂ O, kg/cm ² , PSI, inch HG, inch H ₂ O	
Sensor	Piezoresistive sensor	
Autom. Zero-point adjustment	via magnetic valve Frequency adjustable: 15 sec, 30 sec, 1 min, 5 min, 10 min	
Overload	Measuring range	Overload
	0 to 10 Pa	20000 Pa
	0 to 50 Pa	20000 Pa
	0 to 100 Pa	20000 Pa
	0 to 500 Pa	20000 Pa
	0 to 10 hPa	200 hPa
	-10 to 10 Pa	20000 Pa
	-50 to 50 Pa	20000 Pa
	-100 to 100 Pa	20000 Pa
	-500 to 500 Pa	20000 Pa
	-10 to 10 hPa	200 hPa

Parameters					
Humidity/temperature optional					
Probe	Integrated probe	testo 6613	testo 6614	testo 6615	testo 6617
Type	Channel	Duct heated	Cable trace humidity	Cable with cover electrode monitoring	
Parameters	%RH / °C/°F / °C _{td} / °F _{td} / g/kg / gr/lb / g/m ³ / gr/ft ³ / ppmV / °Cwb / °Fwb / kJ/kg / mbar / inch H ₂ O / °Ctm (H ₂ O ₂)/°Ftm (H ₂ O ₂) / % Vol				
Meas. range					
Humidity / trace humidity	0 to 100 %RH		-60 to +30 °C td	0 to 100 %RH	
Temperature	-20 to +70 °C -4 to +158 °F	-40 to +180 °C -40 to +356 °F	-40 to +120 °C -40 to +248 °F	-40 to +180 °C -40 to +356 °F	
Measurement uncertainty*					
Humidity	Integrated probe	testo 6613	testo 6614	testo 6615	testo 6617
	±(1,0 + 0,007 * MV) %RH for 0 to 90 %RH ±(1,4 + 0,007 * MV) %RH for 90 to 100 %RH		±(1,0 + 0,007 * MV) %RH for 0 to 100 %RH	±(1,2 + 0,007 * MV) %RH for 0 to 90 %RH ±(1,6 + 0,007 * MV) %RH for 90 to 100 %RH	
	for deviations from media temp. ±25 °C: ±0.02 %RH/K				
Dewpoint				±1 K at 0 °C _{td} ±2 K at -40 °C _{td} ±4 K at -50 °C _{td}	
Temp. at +25 °C / +77 °F	±0.15 °C / 32.2 °F Pt1000 Class AA		±0.15 °C / 32.2 °F Pt100 Class AA	±0.15 °C / 32.2 °F Pt1000 Class AA	

Subject to change without notice.

Inputs/outputs	
Analog outputs	
Quantity	Standard: 1; with optional humidity probe: 3
Output type	0/4 to 20 mA (4-wire) (24 VAC/DC) 0 to 1/5 to 10 V (4-wire) (24 VAC/DC)
Scaling	Differential pressure: scalable ±50% of measuring range final value; freely scalable within measuring range
Meas. cycle	1/sec
Resolution	12 bit
Max. load	max. 500 Ω
Other outputs	
Ethernet	Optional
Relay	Optional: 4 relays (free allocation to measurement channels or as collective alarm in operating menu/P2A), up to 250 VAC/3A (NO or NC)
Digital	Mini-DIN for P2A software
Supply	
Voltage supply	20 to 30 VAC/DC, 300 mA current consumption, galvanically separate signal and supply line

General technical data		
Model		
Material	Front plate stainless steel, housing plastic	
Dimensions	without humidity/temperature: 246 x 161 x 47 mm with humidity/temperature: 396 x 161 x 78 mm	
Weight	Version without humidity: 0.9 kg; Version with integrated humidity probe: 1.35 kg; version with preparation for external humidity probe: 1.26 kg	
Display		
Display	optional: 3-line LCD with multi-language operating menu	
Resolution		
Differential pressure	Measuring range	Resolution
	0 to 10 Pa	0.1 Pa
	0 to 50 Pa	0.1 Pa
	0 to 100 Pa	0.1 Pa
	0 to 500 Pa	0.1 Pa
	0 to 10 hPa	0.01 hPa
	-10 to 10 Pa	0.1 Pa
	-50 to 50 Pa	0.1 Pa
	-100 to 100 Pa	0.1 Pa
	-500 to 500 Pa	0.1 Pa
	-10 to 10 hPa	0.01 hPa
Humidity	0.1 %RH	
Temperature	0.01 °C / 0.01 °F	
Miscellaneous		
Protection class	IP 65	
Connection nipple	Ø 6 mm --> suitable hoses 4 mm + 4.8 mm	
Operating conditions		
Mit / ohne	Operation temperature	-5 to +50 °C / +23 to +122 °F
Display	Storage temperature	-20 to +60 °C / -4 to +140 °F
	Process temperature	-20 to +65 °C / -4 to +149 °F

The determination of measurement uncertainty takes place according to GUM (Guide to the Expression of Uncertainty in Measurement):
For the determination of measurement uncertainty, the accuracy of the measuring instrument (hysteresis, linearity, reproducibility), the uncertainty contribution of the test site as well as the uncertainty of the adjustment site (works calibration are taken into account. For this purpose, the value of k=2 of the extension factor, which is usual in measurement technology is used as a basis, which corresponds to a trust level of 95%.
Measurement uncertainty differential pressure ±0.5% of measuring range final value ±0.3 Pa



Differential pressure transmitter in cleanroom-conform panel design

Technical drawings

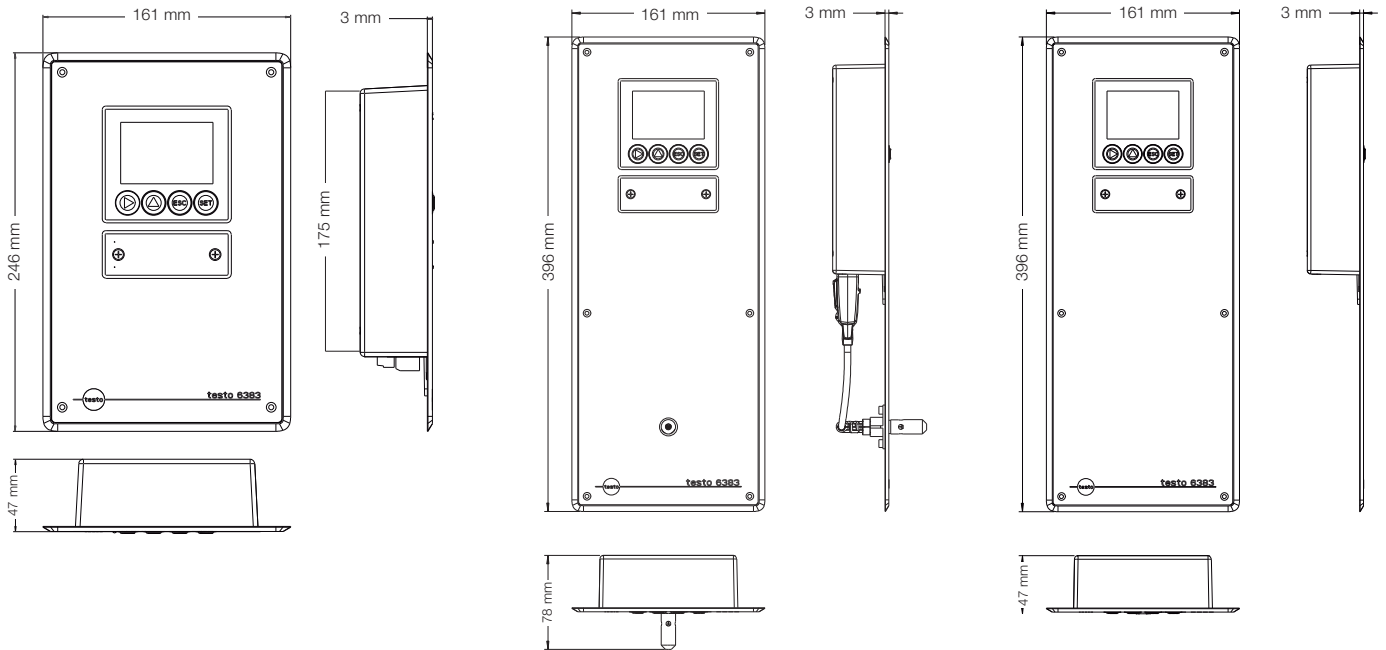

Connection plan

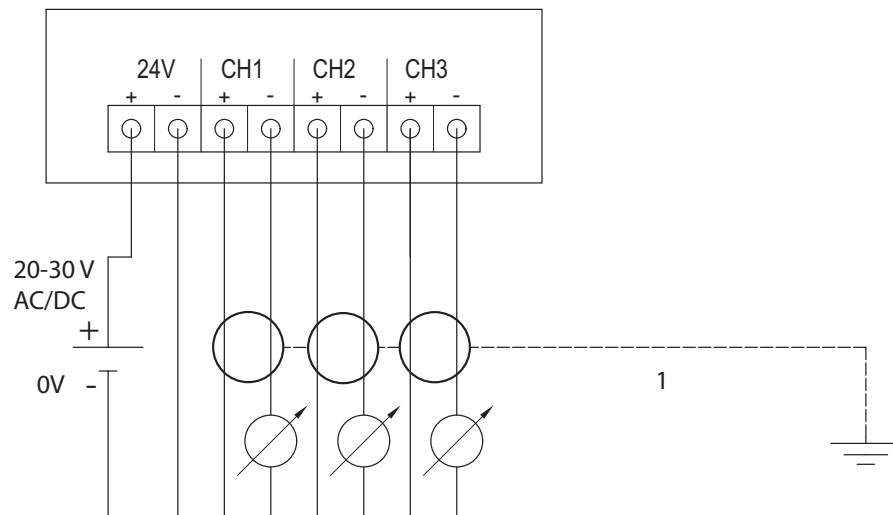



Differential pressure transmitter in cleanroom-conform panel design

The following options can be specified for the testo 6383:

AXX	Measuring range
BXX	Analog display/supply
CXX	Display / menu language
DXX	Integrated humidity probe
EXX	Ethernet
FXX	Differential pressure unit (pre-set)
GXX	opt. Analog output for humidity probe connection (probe series testo 6610) units (pre-set)
HXX	Relay
IXX	Units channel 3 (pre-set, only if opt. humidity probe connection available)

AXX	Measuring range
A01	0 to 10 Pa
A02	0 to 50 Pa
A03	0 to 100 Pa
A04	0 to 500 Pa
A05	0 to 10 hPa
A21	-10 to 10 Pa
A22	-50 to 50 Pa
A23	-100 to 100 Pa
A24	-500 to 500 Pa
A25	-10 to 10 hPa

BXX	Analog display / supply
B02	0 to 1 V (4-wire, 24 VAC/DC)
B03	0 to 5 V (4-wire, 24 VAC/DC)
B04	0 to 10 V (4-wire, 24 VAC/DC)
B05	0 to 20 mA (4-wire, 24 VAC/DC)
B06	4 to 20 mA (4-wire, 24 VAC/DC)

CXX	Display / menu language
C00	without display
C02	with display/English
C03	with display/German
C04	with display/French
C05	with display/Spanish
C06	with display/Italian
C07	with display/Japanese
C08	with display/Swedish

DXX	Integrated humidity probe
D00	no humidity/temperature probe
D04	humidity probe integrated in panel
D05	preparation for external humidity/temperature probe testo 6610

EXX	Ethernet
E00	without Ethernet module
E01	with Ethernet module

FXX	Differential pressure unit (pre-set)
F01	Pa / min / max
F02	hPa / min / max
F03	kPa / min / max
F04	mbar / min / max
F05	bar / min / max
F06	mmH ₂ O / min / max
F07	mmH ₂ O / min / max
F08	inch Hg / min / max
F09	kg/cm ² / min / max
F10	PSI / min / max

Scaling: 50% of measuring range final value; freely selectable within measuring range

GXX	opt. Analog output for humidity probe connection (probe series testo 6610) units (pre-set)
G01	%RH / min / max
G02	°C/Min/Max
G03	°F/Min/Max
G04	°Ctd / min / max
G05	°Ftd / min / max
G06	g/kg / min / max
G07	gr/lb /Min/Max
G08	g/m ³ / min / max
G09	gr/ft ³ / min / max
G10	ppmV / min / max
G11	°Cwb / min / max
G12	°Fwb / min / max
G13	kJ/kg / min / max (enthalpy)
G14	mbar / min / max (water vapour partial pressure)
G15	inch H ₂ O / min/ max (water vapour partial pressure)
G16	°Ctm (mixture dewpoint for H ₂ O ₂)
G17	°Ftm (mixture dewpoint for H ₂ O ₂)
G18	% Vol

only possible when D04 or D05 selected

HXX	Relay
H00	without relay
H01	4 relay outputs, limit value monitoring
H02	4 relay outputs, channel 1 limit values and collective alarm

IXX	Units channel 3 (pre-set, only if opt. humidity probe connection available)
I01	% RH/Min/Max
I02	°C/Min/Max
I03	°F/Min/Max
I04	°Ctd / min / max
I05	°Ftd / min / max
I06	g/kg / min / max
I07	gr/lb /Min/Max
I08	g/m ³ / min / max
I09	gr/ft ³ / min / max
I10	ppmV / min / max
I11	°Cwb / min / max
I12	°Fwb / min / max
I13	kJ/kg / min / max (enthalpy)
I14	mbar / min / max (water vapour partial pressure)
I15	inch H ₂ O / min/ max (water vapour partial pressure)
I16	°Ctm (mixture dewpoint for H ₂ O ₂)
I17	°Ftm (mixture dewpoint for H ₂ O ₂)
I18	% Vol

only possible when D04 or D05 selected

Example:

Order code for transmitter testo 6383 with the following options:

- Measuring range -10 to 10 Pa
- Analog output 4 to 20 mA (4-wire, 24 VAC/DC)
- with German display
- preparation for external humidity/temperature probe testo 6610
- with Ethernet module
- Differential pressure unit kg/cm² / min / max
- opt. Analog output for °Ctd / min / max
- without relay
- Unit channel 3 g/m³ / min / max

0555 6383 A21 B06 C03 D05 E01 F09 G04 H00 I08