

The ST chain hoist



02.2012

Partner of Experts

STAHL
CraneSystems 

The ST chain hoist

The ST chain hoist programme ranks among the world's most distinctive and extensive ranges on offer. Users, crane manufacturers and systems manufacturers appreciate the robust classic which proves itself in operation day for day. It is powerful, reliable and undemanding as regards maintenance and power consumption. The supervised series production of the standard components brings you economic advantages. And in conjunction with the precise manufacture of off-standard components, the ST chain hoist is an acknowledged top level quality product.

The modular system permits numerous combinations of the sub-assemblies to achieve your individual solutions. The ST series from STAHL CraneSystems is available in 13 load capacity variants for the load capacity range from 125 kg to 6,300 kg. The chain hoists can be used as stationary models with suspension hook or eye, with rigid suspension or with a push trolley. Or when completed by an electric trolley they are mounted on standard cranes, off-standard cranes or in systems manufacture. The technical highlight which makes the ST chain hoist one of the safest around is the direct suspension on the patented solid cast iron chain guide. The load is supported at the point where it engages. Various off-standard designs are available for use in particular conditions. Two constructions optimise the effective hook height of all chain hoist models if required. The headroom of the short-headroom trolley and the extra short headroom trolley is reduced

by 33% and over 60% respectively. For exceptional requirements, our experts in the engineering department will develop suitable customised solutions. Even in explosive atmospheres you do not have to manage without the ST chain hoist. On request, nearly the entire chain hoist programme is available in explosion-protected design for Zone 1, Zone 21 and Zone 22. It's no coincidence that we are market leader for explosion-protected lifting technology and crane components.



Standard ST chain hoist with electric trolley



The facts

- The most comprehensive chain hoist programme for the load capacity range from 125 kg to 6,300 kg
 - Patented suspension directly on chain guide
 - Equipped with two hoisting speeds as standard
 - Extremely short and compact construction ensures that space can be utilised to the maximum
 - High standard classification in accordance with FEM
 - Modern Kanban production, available fast
 - Available as an option in explosion-protected design complying with ATEX and IECEx
- Please order our brochure with fundamental information on expertise in explosion protection.

The models and trolley variants

Different construction types and trolley variants for the ST chain hoist open up the most varied applications in crane and systems manufacture. Individually tailored to your specific requirements as stationary hoist or for use with a trolley. The trolleys are equipped as standard with one travel speed, as an option the motors can be supplied with two travel speeds. But in this matter too we are open to your requirements. Our chain hoists are known worldwide for their flexible and versatile use. Compact dimensions and extremely short approach dimensions help to make optimum use of the production shop.

Suspension for stationary version

The standard stationary ST chain hoist has hook suspension. However you can also choose eye suspension or rigid suspension. The eye suspension is used when the stationary chain hoist is only rarely moved to a different location, while the low headroom permits long hook paths even in low-ceilinged rooms. If the ST chain hoist is to be permanently mounted, for example in systems manufacture, we recommend rigid suspension. Here too the extremely short headroom is of advantage. In addition, the rigid mounting prevents the chain hoist swinging on the trolley.

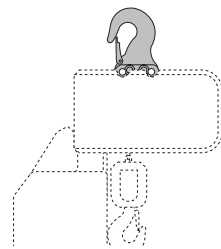

Hook

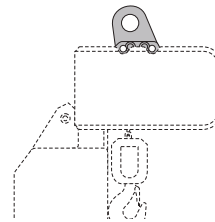

Eye

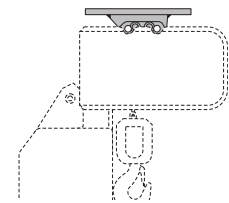

Rigid suspension

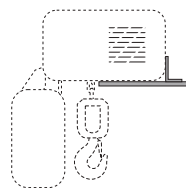

ST05 mounting

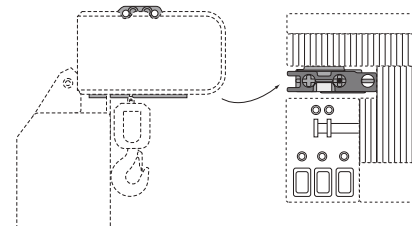

ST10 – ST60 mounting

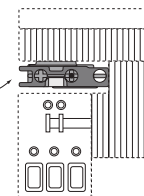

(view from below)

Foot mounting for stationary version

In order to utilise space optimally in low-ceilinged rooms the ST chain hoist can be bolted from below onto a foot mounting.

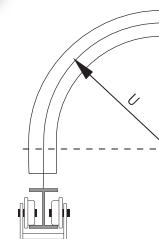
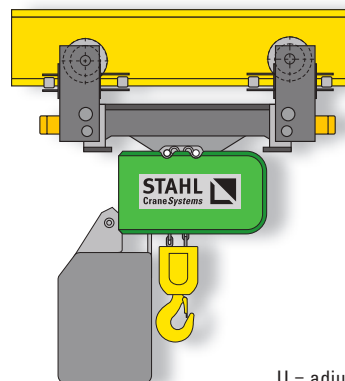
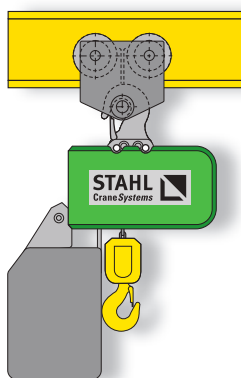
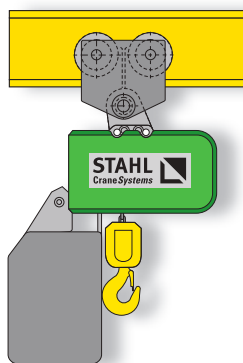

U = radius of bend down to 800 mm possible

Push trolley

In standard version, the ST05 and ST 10 1/1 chain hoists are suspended by eye or hook from the smooth-running push trolleys. Rigid suspension of the chain hoist is possible on request. The push trolley does not affect the low headroom of the hoist. Optional wheel arresters make your workplace safer.

DUE articulated trolley

The DUE articulated trolley is available for frequent travel around bends and narrow radii. Depending on radius of bend, runway flange width or application it is equipped with one or two travel motors. The lateral guide rollers cause minimum wear. The DUE articulated trolley is designed for load capacities up to 6,300 kg.

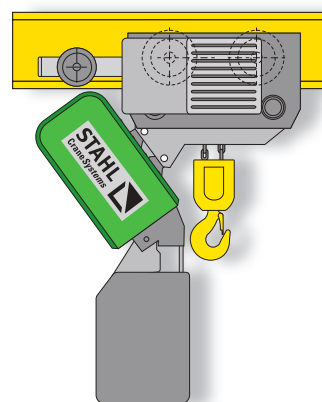
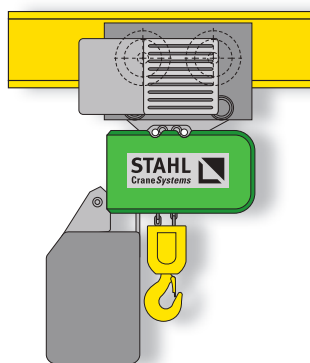

Standard headroom electric trolley

Even with the smooth-running electric trolley the extremely short headroom permitting long hook paths is typical.

Short headroom electric trolley

The smooth-running electric trolley can also be combined with the ST short headroom chain hoist, reducing the headroom by a further 33%.

■ Standard
□ Option

Type	Load capacity up to [kg]	Stationary	Push trolley	Electric trolley	Articulated trolley	Short headroom trolley	Extra short headroom trolley	Dual chain hoists	
								STD	STD Vario
ST 05	125 – 630	■	■	■	■	■	■	■	□
ST 10	500 – 1,000	■	■	■	■	■	□	■	□
ST 20	1,000 – 2,000	■	■	■	■	■	□	□	□
ST 30	1,250 – 3,200	■	■	■	■	■	■	■	□
ST 50	2,500 – 5,000	■	■	■	■	■	■	■	□
ST 60	3,200 – 6,300	■	■*	■	■	■	□	■	□

* The ST60 is only available with 1/1 reeving in the standard programme.

The STK extra short headroom trolley

If you do not want to lose even a millimetre of lifting height, the STK extra short headroom trolley from STAHL CraneSystems is just the thing for you.

The construction of the short headroom trolley itself saves a tremendous amount of space. The body of the chain hoist is mounted at an angle, meaning that no return sheave is required. This reduces the headroom by 33%. The extra short headroom trolley with its headroom reduced by 60% achieves maximum hook paths particularly in extremely low-ceilinged rooms and fully deserves its name. The distance from the underside of the beam to the bed of the hook is just 210 mm at a load capacity of 5,000 kg and 185 at 3,200 kg. These dimensions are extremely small and are unique at present. The chain hoists used here, mounted vertically, are based on the standard ST chain hoist programme from STAHL CraneSystems.

The patented chain drive is unique. Two separate chains running in synch act on a single bottom hook block. The load is lifted and positioned without swinging or vibrating.

The facts

- Compact dimensions achieving maximum height of lift
- Specially developed for low-ceilinged rooms
- Low deadweight
- Load is lifted steadily and without swinging
- Largely maintenance-free
- Trolleys with no projecting edges for steady cross travel
- Available as an option in explosion-protected design complying with ATEX and IECEx

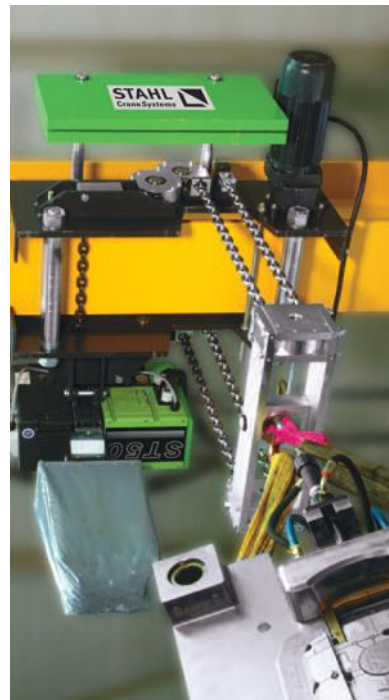

The patented design of the extra short headroom trolley reduces its headroom by 60% and permits exceptional lifting heights particularly in low-ceilinged rooms.

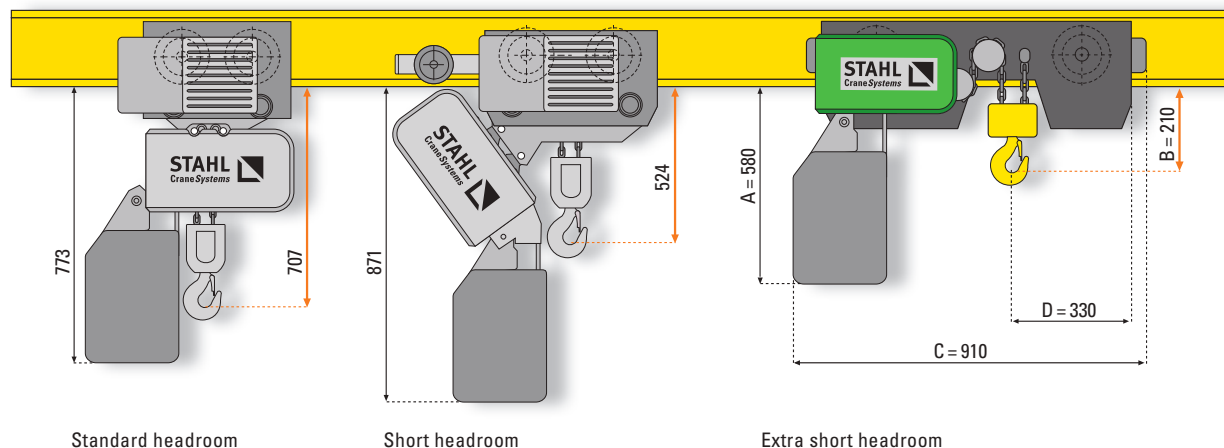

The dimensions apply to an ST chain hoist with a load capacity of 5,000 kg and standard lifting height of 3 m.

Type	STK 0502-8/2 2/2-1	STK 0502-8/2 4/2-1	STK 3016-8/2 2/2-1	STK 5025-8/2 2/2-1	STK 3016-8/2 4/2-1	STK 5025-8/2 4/2-1
Load capacity	500 kg	1,000 kg	1,600 kg	2,500 kg	3,200 kg	5,000 kg
Hoisting speed (50 Hz)	8 m/2 min	4 m/1 min	8 m/2 min	8 m/2 min	4 m/1 min	4 m/1 min
Hoisting speed (60 Hz)	10 m/2.5 min	5 m/1.2 min	10 m/2.5 min	10 m/2.5 min	5 m/1.2 min	5 m/1.2 min
No. of falls	2	4	2	2	4	4
Output (50 Hz)	0.8/0.2 kW	0.8/0.2 kW	2.3/0.57 kW	3.8/0.9 kW	2.3/0.57 kW	3.8/0.9 kW
Output (60 Hz)	0.96/0.24 kW	0.96/0.24 kW	2.8/0.68 kW	4.6/1.1 kW	2.8/0.68 kW	4.6/1.1 kW
Dimensions	Dimensions stated are approximate (subject to alterations)					
A	260 mm	490 mm	520 mm	580 mm	520 mm	580 mm
B	136 mm	151 mm	185 mm	210 mm	185 mm	210 mm
C	565 mm	750 mm	800 mm	910 mm	800 mm	910 mm
D	264 mm	290 mm	300 mm	330 mm	300 mm	330 mm

Other hoisting speeds, supplementary equipment such as gear limit switch and explosion-protected designs are possible. Please enquire.

The STD dual chain hoist

The STD dual chain hoist is an off-standard development for long goods and loads which need to be picked up at two points. It has two load chains which are driven in synch by a single hoist motor. The distance between the hooks can be selected to suit the goods to be transported. The design means that the two running hooks running in synch lift and transport the load without dangerous tilting. Its low headroom makes the STD dual chain hoist suitable for low-ceilinged rooms too and achieves maximum hook paths.

There are different versions of the STD dual chain hoist available. Depending on the requirements or the space available there are versions where the load hooks are either to both right and left or only on one side of the chain hoist. For stationary use, the STD chain hoist, adapted to the width of the load, is rigidly mounted on a substructure. In combination with an electric trolley the STD chain hoist becomes mobile. The STD Vario dual chain hoist with its electrically adjustable distance between hooks allows goods of different lengths to be lifted without difficulty, transported, and accurately positioned. Even when the loads have different lengths or the load hooks are differently loaded, the two load hooks run steadily and completely in synch.

The facts

- Low space requirement permitting maximum height of lift
- Two hook lead-offs running in synch on one hoist
- Synchronous even with uneven loading, no load swing
- Individually adapted to width of load
- Largely maintenance-free
- Optionally available in explosion-protected design complying with ATEX and IECEx



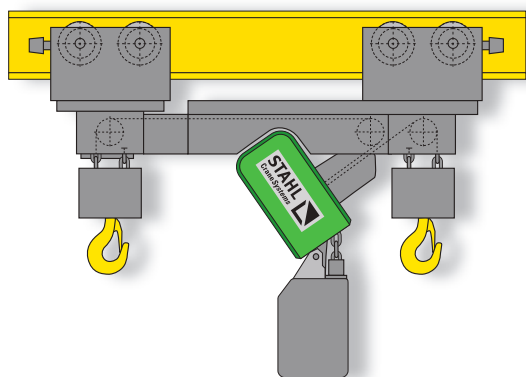

›Z‹ design

The load hooks are on the left and right of the chain hoist.

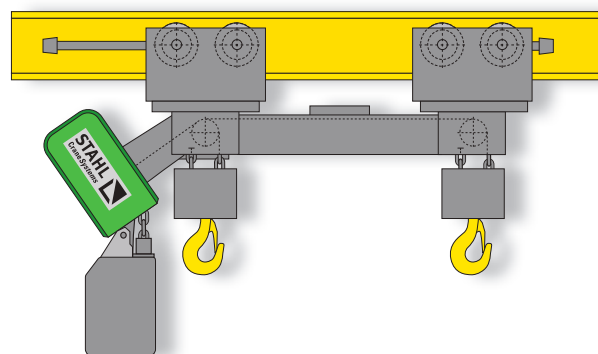

›E‹ design

The load hooks are on one side of the chain hoist.

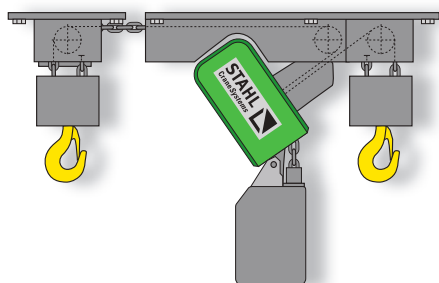

Stationary dual chain hoist

The STD chain hoist is adapted to the width of the load and rigidly mounted on a substructure.

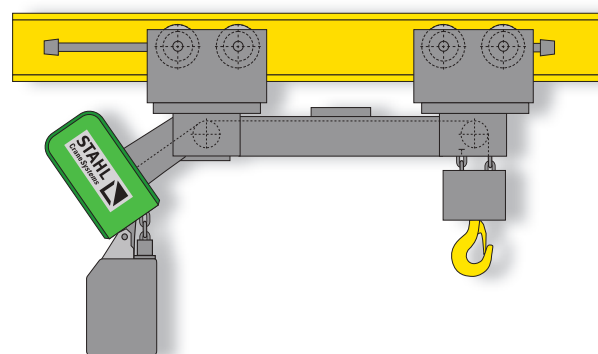

STB Big Bag design

The Big Bag version is designed for load capacities up to 3,200 kg. Its special feature is the free choice of the distance between chain hoist and load hook which makes lifting bulky loads or Big Bags up to top hook position possible without hindering edges such as trolley, chain hoist or chain box.

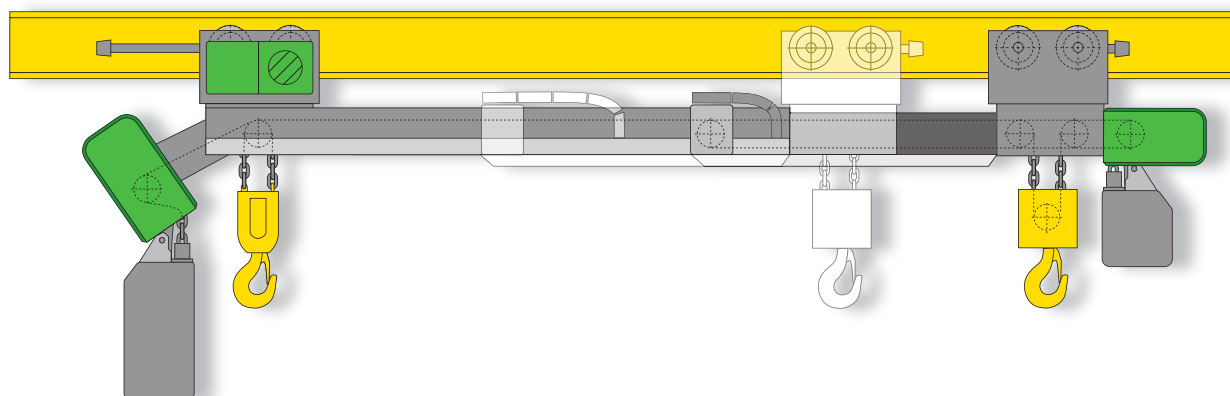

The STD Vario dual chain hoist

The distance between hooks is electrically adjustable and can be individually adapted to loads of different lengths. Both hooks run absolutely in synch. The load hooks cannot be accidentally shifted during lifting or travel.

The technology

It's reassuring to know what convincing technology is concealed in the robust ST chain hoist. The largely maintenance-free components of the modular chain hoist are optimally matched to each other. They guarantee constant performance, high efficiency and long service life. One of the main features guaranteeing safety in the workplace is the patented solid cast iron chain guide. The load-bearing components are integrated into this component so that the load is supported where it engages. The direct suspension means that the power flux is not diverted via the housing.

1 Chain drive



- Innovative patented chain drive (DE 198 49 693 C2)
- Anchorage and load-bearing components are directly integrated into the high-tensile grey cast iron
- Simple inspection and replacement of the chain sprocket thanks to over-mounted shaft bearing
- Enclosed self-lubricating chain guide
- Reliable functioning even in demanding applications
- Wear-resistant case-hardened chain sprocket in conjunction with optimised return sheaves; ensuring low wear on the chain

2 Motor



- High standard classification in accordance with FEM
- Powerful motors with high duty cycle and number of switching operations
- Standard fan cooling
- Two hoisting and travel speeds as standard permitting the load to be positioned accurately
- Single-speed and four-pole versions are available as options
- Ptc thermistor temperature control

3 Control



- All customary connecting and control voltages are available
- Plug connection of control pendant and travel motor
- Clear arrangement of contactors
- As an option, available with direct control
- As an option, available without control pendant and/or contactor control

4 Brake



- Low-maintenance, asbestos-free electromagnetic disc brake
- Oversized braking torque
- Long-lived, brake wear can be checked and measured
- Safe in inching operation
- Brake completely enclosed, protected from humidity, vapours and dusts from the exterior; ensuring long-term reliable operation

5 Paint



- Standard paint treatment as per RAL 6018 yellow-green and RAL 7021 greyish black
- High-quality primer and top coats for standard applications
- Off-standard paint treatment for outdoor use or corrosive ambient conditions
- Shade as per customer's requirement

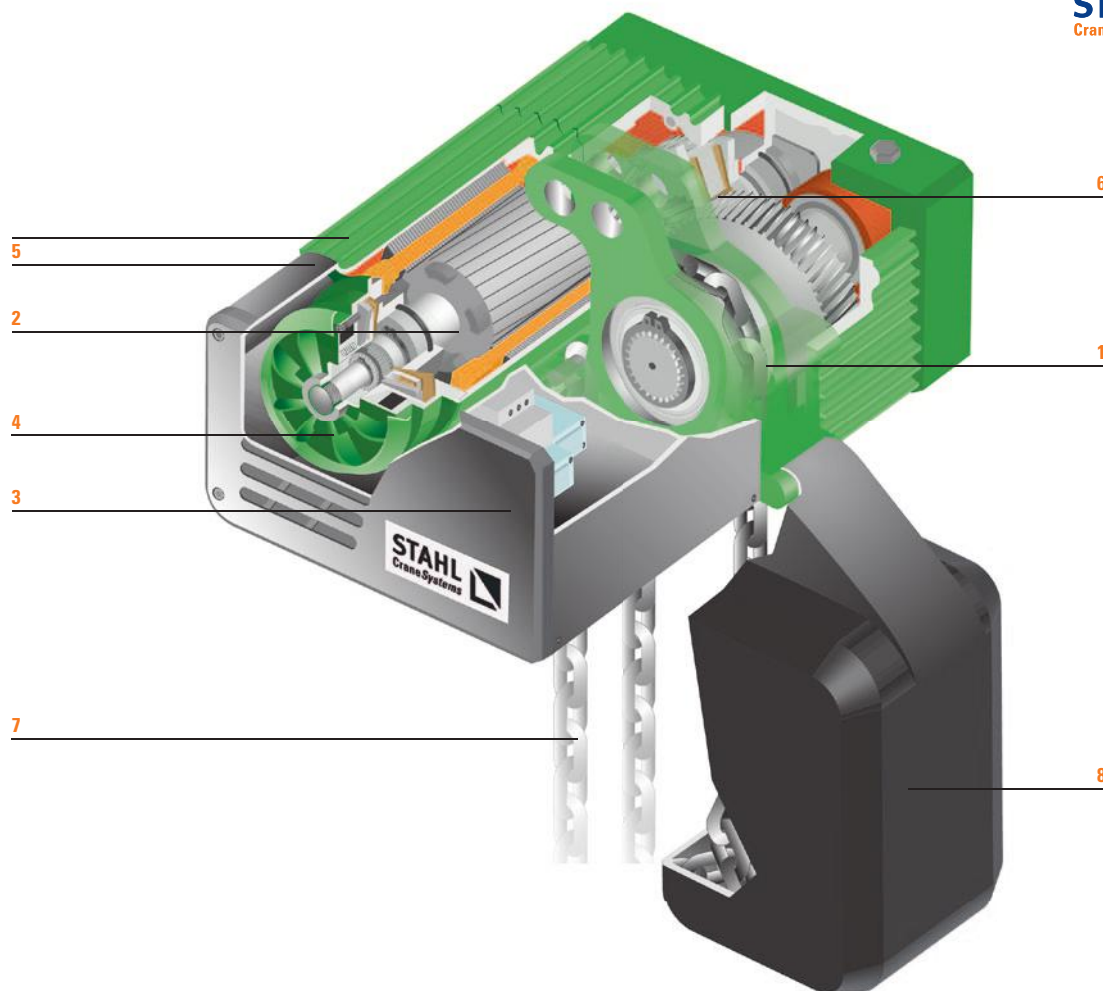

6 Overload slipping clutch and gear



- On the ST10 – ST60, the slipping clutch is situated in the oil-cooled gear
- Easily adjustable from the exterior
- Precise response
- No electronic limiting necessary
- Various gear reductions available
- Innovative materials

7 Chain



- Surface-hardened, galvanised and large dimensioned load chain
- High case depth for long service life
- High FEM classification
- Stainless steel load chains are available as an option

8 Chain box



- Large selection of chain boxes in plastic, sheet steel or textile
- Available without chain box as an option

The equipment

There's always room for improvement. Although it is first-class in the standard version, you have the option of making your ST chain hoist even safer, more cost-effective, more convenient with numerous mechanical, electrical and electronic features. As a welcome side-effect, the service life of the chain hoists is prolonged. The supplementary equipment increases the performance of the chain hoist and adapts it to your individual requirements. Here we show you just the most interesting supplementary equipment and options. If you need further detailed information, please pay a visit to our website at www.stahlcranes.com, or contact us directly.

STH control pendant



- Robust control pendant with EMERGENCY STOP palm button and control cable
- All switching elements for hoist, cross and long travel are 2-step
- IP 65 protection
- Additional buttons, for example to activate a horn, can easily be fitted.
- Optional load display. All data displayed can be read out on a notebook with the aid of the SMC Multicontroller.

Radio remote control units



- micron push-button transmitter with belt clip, as an option signal feedback from crane
- spectrum joystick transmitter with harness
- Automatic battery chargers with replacement batteries

RMI RadioMOVEit radio remote control



- Ergonomic one-hand pushbutton radio remote control with emergency stop function for all chain hoists
- Suitable for right- and left-handed operators
- Covers the whole load capacity range
- Spiral cable does not restrict the height of lift
- The remote control unit can be positioned anywhere on the chain fall independent of chain size
- Load is guided directly with the non-slip handles

SMC Multicontroller



- Continuous load monitoring by overload cut-off even if hoist is at a standstill
- Overload protection with ALC automatic load control
- Load spectrum memory for load-related operating time summation
- Monitoring of motor temperature for hoist and travel motors
- Operating data registration, e.g. operating hours, load spectrum, motor switching operations and load cycles
- Data exchange with PC possible

SSC cumulative load control



- Load control by overload cut-off, increased safety when operating with more than one load hook
- Maximum of four separate loads can be registered
- Separate loads are measured and hoisting disconnected if permissible limit load is exceeded
- Differential load monitoring possible
- Using the flexible SSC cumulative load control increases the safety of material transport and prevents overloading the system.
- Optionally available with certified load summation in category »3 Performance Level d« and EN 954

Operational hoist limit switch



- Two versions are possible: cut-off in top hook position or cut-off in top and bottom hook position (stationary, push trolley, electric trolley)

Steel chain guide

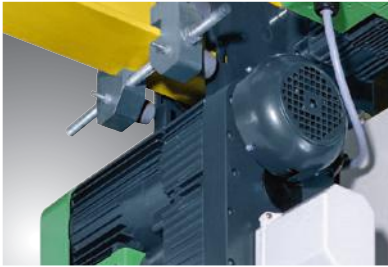

- Heavy high-tensile chain guide for rugged use
- Oversized load chain with 5-pocket chain sprocket
- Chain drive is completely enclosed
- Suitable for particularly demanding application conditions
- Extremely wear-resistant case-hardened chain sprocket

Bypass brake

- Second brake for increased safety
- Identically dimensioned
- During a breakdown, the second brake automatically takes over the function of the main hoist brake
- Second brake acts directly on the load, i.e. bypassing the slipping clutch

Vibration damper

- Available for chain hoists STD 10 to STD 60
- Minimises the vibrations produced by operating the chain hoist and transmitted to the load chain via the chain sprocket (polygon effect)

Load display

- SLD four-digit 7-segment load display (Stahl Load Display), large format, luminous red, available with various interfaces including CAN.
- Choice of 60, 100 or 150 mm digit height
- No additional sensor is required as the standard load sensor is used.

FMD1 slipping clutch test device

- Robust full metal design
- Modern electronic test apparatus with field-proven sensor technology, high degree of accuracy $\pm 2\%$
- Test range up to 4,000 kg on one chain fall, suitable for chains up to 11.3 mm link thickness
- Protector for evaluation device and internal test program
- Simple intuitive handling

		Standard	Options
Ambient temperature		-20 °C to +40 °C	to +50 °C
Protection to IEC/EN 60529		IP 55	IP 66
Paint	Colour	Greyish black/yellow-green RAL 7021/6018	All other colours from RAL colour chart
	D.F.T.	80 µm	120 µm to 240 µm
	Paint	Polyurethane topcoat	Epoxy-resin base (240 µm)
Control pendants		STH 1 control pendant with EMERGENCY STOP palm button	Radio remote control in pushbutton or joystick version
			MOVEit one-hand control switch
Control		Contactor control including main contactor	For crane manufacturers, contactor control without transformer and without crane switch contactor
			Direct control (ST05 – ST20)
Hoist motor control		Pole-changing	Frequency controlled
Travel motor control	50 Hz	20 m/min	2.5/10 m/min and 5/20 m/min
	60 Hz	25 m/min	3.2/12.5 m/min and 6.3/25 m/min pole-changing or frequency controlled
Motor supply voltage	50 Hz/60 Hz	380 – 415 V ST05 also 380 – 400 V or 415 V	All voltages possible
Chain	grade 8 to DIN 5684	Galvanised	Stainless steel chain, off-standard chain (hardened)
	Safety factor	≥ 5,0	–
Chain guide		Grey cast iron EN GJS	Sandwich chain guide made of hardened spring steel plates
Chain box		Plastic, textile	Sheet steel
Load lifting elements		Load hook in bottom hook block	Thread bar, VAGH safety load hook
			Galvanised load hook
Limit switches		–	Emergency hoist limit switch (gear limit switch)
	Travel limit switch	–	For up to four switching functions – pre- and end limiting in both directions of travel, carriage spacing
Overload cut-off		Slipping clutch	Load sensor
	Signal transmitter	–	Horn, flashing light
	Visualisation	–	SLD large-format load display, display in control pendant, readable on PC
	Data exchange	–	with PC
Cumulative load controller		–	SSC
Temperature control of travel motors		–	Ptc thermistors
Mechanical safety devices		–	Wheel arresters
		Guide rollers for wide flange widths dependent on trolley type	Guide rollers for narrow flange widths
		Support rollers for trolleys	–
Hoist brake		Monodisc spring-loaded brake with asbestos-free brake linings	Manual release of hoist brake
			Bypass brake, double brake
Data recording		–	Operating hours counter
Panel box		Plastic (Terluran 969 T)	ST 10 – ST 60 sheet steel (S 235 JR)

The Engineering

Engineering means innovation and individuality. Constantly redefining the lifting and transporting of loads for complex requirements is a job for our experts. Drawing on one of the widest product ranges of standard components, they regularly develop modern, individual off-standard and customised solutions. Hardly any other manufacturer of lifting and crane technology can offer you this diversity of precisely designed top quality customised solutions combined with maximum cost-effectiveness. The modular ST chain hoist programme forms the basis for the most varied solutions. Compact construction, extremely low headroom, twin chain hoists or multi-reeved chain hoists, STB Big Bag hoist, coupled chain hoists for four-point load pick-up. Various trolleys are available for all chain hoists. Customised system solutions individually adapted to your precise requirements are our forte. The experience and knowledge gained from over 130 years of crane technology give us the flexibility to develop and produce the optimum solution for your project in short time. On request, all off-standard chain hoists and customised solutions are available in explosion-protected design for Zone 1, Zone 21 and Zone 22.

The facts

- Perfectly matched to your project
- Every hoist is the result of over 130 years of experience and expertise
- Short development time
- Cost-effective thanks to modular system
- Technically mature thanks to the use of field-proven standard components
- High quality and reliability ensured by in-house production
- All customised solutions are available as an option in explosion-protected design complying with ATEX and IECEx.



ST chain hoist with 30,000 kg load capacity

This off-standard design comprising four ST60 chain hoists from STAHL CraneSystems is designed for the impressive load capacity of 30,000 kg and is used on a maintenance crane in a metallurgy plant in New Caledonia. Loads in this range are normally lifted with wire rope hoists.

Due to the extreme requirements such as restricted space, short approach dimensions, narrow track gauge and true vertical lift a solution with wire rope hoists is not possible. The construction of chain hoists ensures true vertical lift, and they have extremely compact dimensions. This prompted STAHL CraneSystems' engineers to develop an off-standard solution with the robust ST60 chain hoists. The chain hoists are cardanically coupled in pairs ensuring that the hoists run in synch. They were reeved with twice 130 m robust chain with a deadweight of 700 kg. The multi-reeved chains withstand maximum stresses. The chain hoists are disconnected in top and bottom hook position by a gear limit switch. To provide increased safety, the loads are continuously registered by load sensors which disconnect the hoist at overload.

The hoist is mounted on an off-standard design double rail crab with specially developed wheelblocks. With a track gauge of 2,000 mm and a wheelbase of 1,660 mm its dimensions are extremely compact.

The facts

- Combination of four ST60 chain hoists
- 12/4-1 reeving
- Load capacity 30,000 kg
- True vertical lift
- Extremely short approach dimensions
- Track gauge 2,000 mm



STD dual chain hoist in series production system

STAHL CraneSystems' engineers designed a cost-effective and reliable overhead monorail system with semi-automatic control for an assembly line. Eight STD dual chain hoists are used on a 93 m closed circular runway to pick up 250 kg components and lift them in synch at two points. The two-point load pick-up ensures that the load is transported safely without swinging.

A buffer store of five trolleys carrying components is ready at the assembly point. Attaching the loads at the loading station is activated manually by radio remote control. Lifting and transport to the buffer store are then automatic. As soon as a new product arrives at the assembly line, the fitter calls for the components by radio remote control. The trolley moves into an unloading station and automatically follows the assembly line at the same speed. The longitudinal position above the line can be corrected by accelerating or braking the drive. Correcting the trolley position at right-angles to the assembly line is possible on a movable skid with a path of 500 mm. Dangerous diagonal pull of the loads is thus prevented.

To increase process reliability, in addition to the radio signal an infrared signal with limited reach is transmitted to the trolleys. Furthermore, a trolley can exit the runway to a maintenance spur via a switch point and be serviced there. The other dual chain hoists are not affected and continue to operate without disturbance.

The facts

- Eight STD chain hoists with monorail trolleys
- Closed KT2000 circular runway, 93 m long
- Power supply via integrated eight-pole conductor line
- Radio control with redundant infrared signal
- Travel speed synchronised with assembly line
- Chain hoist can be moved at right-angles to the runway on an off-standard skid



ST chain hoist for wind turbines

STAHL CraneSystems' engineers developed an off-standard chain hoist for maintenance work on wind turbines, specifically for raising spare parts up into the nacelle.

The ST10 chain hoist with single-fall load chain is normally used for lifting loads up to 500 kg. For the wind turbines, the ST10 chain hoist was designed with a load capacity of 250 kg. The resulting weight reduction permitted the hoisting speed to be increased to 25 m per minute. 50 % time is saved compared with the standard speed of 12 m per minute. The temperature rise in the motor is correspondingly low.

The large chain box and the push trolley which can be locked in any position on the runway were developed especially for use in wind turbines. Further constructional details adapt the ST10 hoist optimally to the operating conditions in wind turbines. An electric limit switch for top and bottom hook positions prevents the load hook damaging the cladding of the tower.

Many wind turbines are situated in offshore wind parks on the open sea. STAHL CraneSystems offers chain hoists with off-standard paint, off-standard materials and various adaptations for the rugged use in saline air.

The facts

- ST10 chain hoist with 250 kg load capacity
- Hoisting speed 25 m/min
- Height of lift 110 m
- Larger chain box
- Elastic suspension for chain box
- Pouch for control pendant
- Push trolley can be locked in any position
- Additional mechanical fall arrester for the chain box





The explosion-protected STex chain hoist

ATEX

IECEX

STAHL CraneSystems is known internationally as an explosion protection specialist and is regarded as world market leader in explosion protection technology. The safety of people and machines in areas subject to gas and dust explosion hazards is our top priority. Here we make no compromises. As developer of numerous innovations in this field we have had palpable influence on crane technology. Experience and know-how from many decades, our own fundamental research and development, approvals from the Federal Physico-Technical Institute (PTB) and other test institutes in many countries underline our expertise. Hoisting technology from STAHL CraneSystems ranks among the safest technology on the market in the chemical, petrochemical and pharmaceutical industries, the food processing industry, power supply, shipbuilding, offshore and natural gas liquefaction industries (LNG).

Without exception, the STex chain hoist programme is based on the modular ST chain hoist programme.

All components of the explosion-protected chain hoists come from our in-house production, from motor and brake to controls and control pendant. For this ensures the complete, high-quality explosion protection on which users, crane manufacturers and system manufacturers all over the world have relied for decades. The strict ATEX directives and IECEx regulations on mechanical and electrical explosion protection are of course met.

The facts

- Internationally leading specialist for explosion protection technology
- The world's first complete, most comprehensive chain hoist programme for Zone 1, Zone 21 and Zone 22
- Based on the ST chain hoist
- Design and maintenance to ATEX and IECEx in certified quality
- All equipment available in explosion-protected design

Use	Category	Protection against	Explosion protection class
Zone 1	II 2 G	Gas	Ex de IIB T4 or Ex de IIC T4
Zone 21	II 2 D	Dust	Ex tD A21 IP 66 T 120 °C
Zone 22	II 3 D	Dust	Ex tD A22 IP 66 T 120 °C

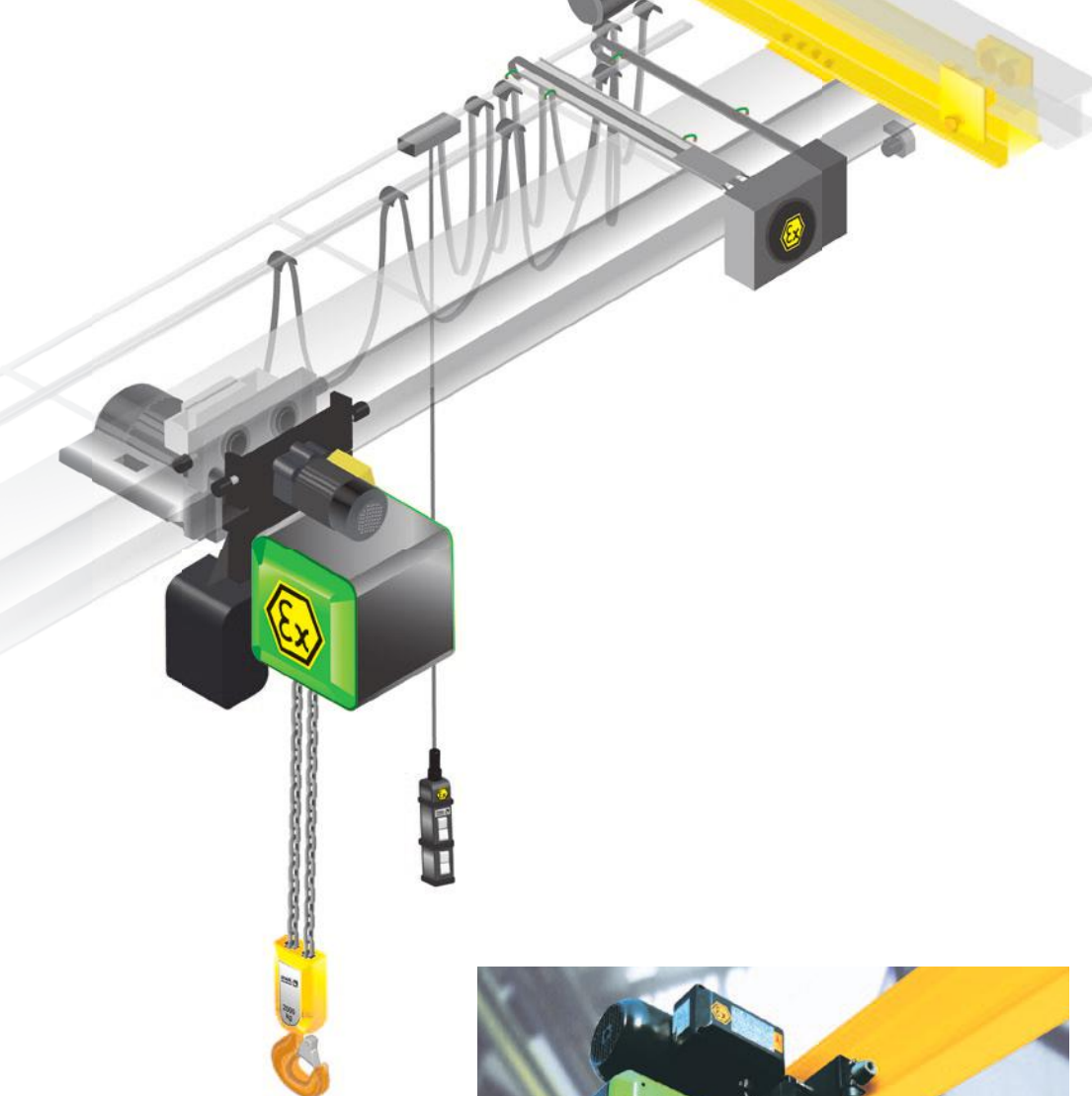

The ST ex chain hoist for Zone 22 is available in six frame sizes up to a load capacity of 6,300 kg.



The ST ex chain hoist for Zone 1 and Zone 21 is available in two frame sizes up to a load capacity of 5,000 kg.



The support

Quality right down to the most minor detail is the standard STAHL CraneSystems is committed to. Not only in the field of crane technology, but also on the subject of support. You will find lifting and crane technology from STAHL CraneSystems all around the world. Developed by engineers and experts, manufactured with maximum care following our well-known standard of quality. All around the world, many companies from various fields have decided on maximum safety and quality, on products from STAHL CraneSystems.

When it comes to sales, we are committed exclusively to capable, professional crane manufacturing partners. You can expect optimum support from them when your individual crane system with components from STAHL CraneSystems is at stake. Consulting and erection of a new system, system-oriented testing and maintenance, modernisation, spare parts supply and training courses. Together with our subsidiaries and crane manufacturing partners we offer you perfectly coordinated support all over the world.



**Spare parts – accessible right around the clock**

Our own subsidiaries and numerous partners around the world ensure reliable spare parts supply and expert assistance in your area. Even decades after a series has been discontinued, spare parts are available all over the world right around the clock.

**Training courses**

We constantly keep our regional crane manufacturing partners up to date with training courses, seminars and information material. You too can profit directly from our expertise. We impart practical and theoretical knowledge in our own training centre or on your premises. The seminars on offer in the form of individual, basic and advanced courses cover all main product groups. However we would also be pleased to match a special programme to your individual specifications and requirements.

You will find our current seminar programme at www.stahlcranes.com/de/support

**Factory service centre – in action all over the world**

Our factory service centre is a service for our customers: wherever you are we assist your crane or systems manufacturer with our experience and expertise whenever he needs us. Up-to-date diagnostic apparatus and condition monitoring systems stand by to support professional service and maintenance work. Not only you, but your system, are in safe hands. You can rely on us.

Your will find our online service at www.web.stahlcranes.com and you can reach our factory service centre on customer.service@stahlcranes.com



The ST chain hoist in action

Experts in all countries immediately recognise hoists and crane components from STAHL CraneSystems. For the ST chain hoist is in action all around the world in the most diverse variants and solutions. Innovative, thought through down to the most minor detail and manufactured with greatest care, the ST chain hoist continues to conquer new areas of application. It thus proves its well above average flexibility and cost-effectiveness. STAHL CraneSystems is represented on all continents by subsidiaries, sales and crane manufacturing partners.





4

1 An ST 20 explosion-protected chain hoist with a load capacity of 1,600 kg is used for outdoor maintenance work in a chemical plant. The narrow construction of the explosion-protected chain hoist enables the whole width of the crane bridge to be used. The travel drives of the suspension crane endcarriages are also explosion-protected.



5

2 Chain hoists of various models are used with single girder suspension cranes in a sawmill in the Netherlands.

3 Only 210 mm high: the extra short headroom trolley makes optimum use of the hook path in the low-ceilinged building of a plastics casting factory in combination with the ST 50 chain hoist for a load capacity of up to 5,000 kg. The headroom reduced by over 60 % simultaneously increases the height of lift.

4 Two STD dual chain hoists with the aid of four synchronously operating load hooks enable long goods weighing 10 tonnes to be transported without swinging.

5 Two STD dual chain hoists ensure safe handling of heavy paper reels in Büttenpapierfabrik Gmund. The STD dual chain hoist is also suitable for low-ceilinged rooms thanks to its low headroom.

6 48 off-standard chain hoists operate in extremely high humidity in a coating plant for the motor industry in China.



6





5



6



7

- 1 The robust ST10 chain hoist with gear limit switch for top and bottom hook position is used with a push trolley on a curved runway
- 2 A light crane system with ST05 chain hoists provides assistance in the repair, maintenance and servicing of racing cars
- 3 The single-fall design of the ST50 chain hoist permits fast hoisting speeds for load capacities up to 2,500 kg. It is mounted with a push trolley on a wall slewing crane.
- 4 Big Bag beams are lifted up to top hook position without any hindering edges with the Big Bag design for load capacities up to 3,200 kg.
- 5 Several ST chain hoists are used in England for the maintenance and replacement of railway lines. All the chain hoists are equipped with off-standard load pick-up equipment. The chain hoists are centrally controlled to ensure that they operate in synch. They are disconnected by gear limit switches which reliably limit the hoisting process.
- 6 Picture 5: Rails being dismantled, the chain hoists have three-fall reeving and a load capacity of 7,500 kg each.
Picture 6: Rails being loaded up.
- 7 A chain hoist with short headroom trolley is installed on a single girder overhead travelling crane. It is used for transporting fork-lift truck batteries to the charging station.

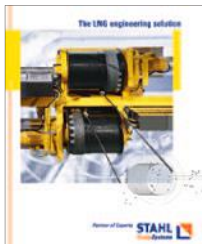
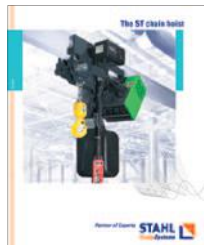
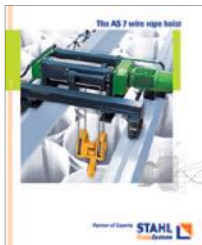

Presented by

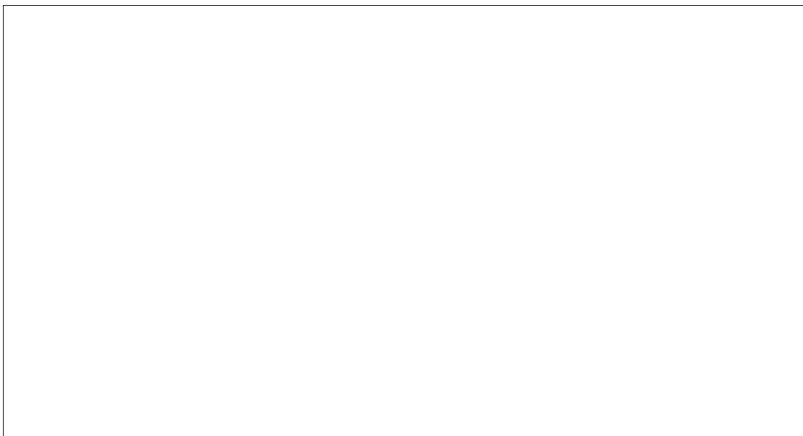

→ www.stahlcranes.com

STAHL CraneSystems GmbH
Daimlerstr. 6, 74653 Künzelsau, Germany
Tel +49 7940 128-0, Fax +49 7940 55665
marketing.scs@stahlcranes.com

Partner of Experts

