

ENHANCED VISION SYSTEMS



The use of mmW RF imaging technology (94 GHz) provides a powerful solution to landing in all visibility conditions, including white-out and brown-out. It has significant benefits over IR imaging methods in the range of conditions it can accommodate, and the detail with which obscured objects can be imaged.

Precision Solutions' parent company, MBDA has been a leading exponent of mmW RF seeker technology for over 20 years and is the first defence company in the world to exploit the technology in volume production. As a result of its experience, especially on the Brimstone RF seeker development, Precision Solutions is able to offer derivatives of the seeker technology with defence, security and commercial applications.

- ▶ An imaging radar sensor to enable pilots to land in zero height, zero visibility conditions.
- ▶ Alternative applications of the same core radar unit for military, quasi-military and commercial deployments.
- ▶ A landing aid for helicopter pilots to enable landing in helicopter induced dust or sand clouds (brown-out) or snow (white-out).
- ▶ A rapid throughput personnel security scanning device.

None of these require significant changes to the sensor architecture. In each case an application specific antenna, software and interfaces are all that is required.



The fundamental architecture of the mmW RF seeker is as follows:

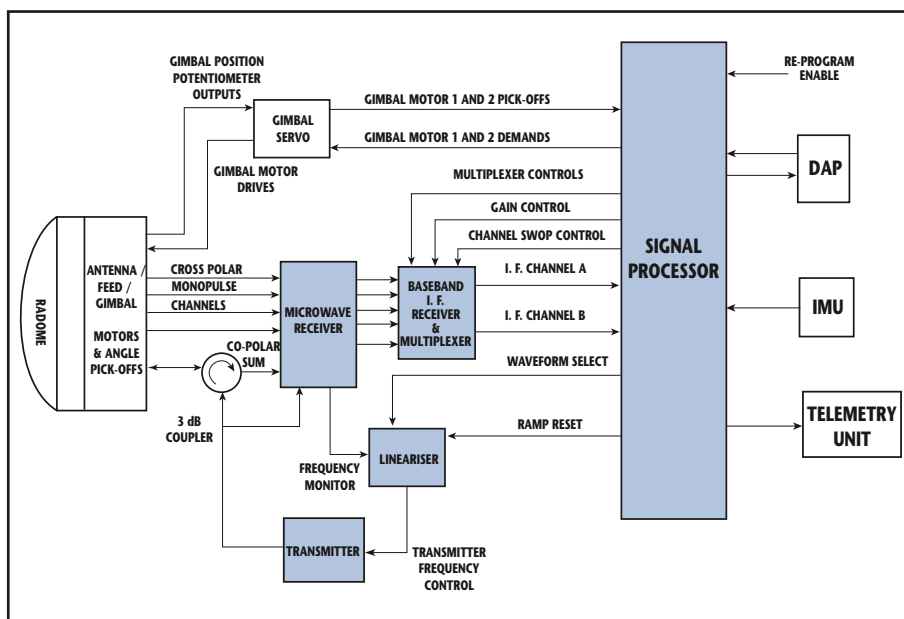

The shaded elements of the image remain unchanged for each of the applications.

This technology offers significant benefits:

- ▶ A mature design
- ▶ Short development timescales – most of the design is off-the-shelf
- ▶ Low risk

Zero height, zero visibility landing

The landing aid, known variously as ALG - Autonomous Landing Guidance - and AALC - Autonomous Airborne Landing Capability - has been extensively trialled in the USA on both military and commercial aircraft and, as a result of the successful programme, aircraft equipped with ALG are cleared to land in 0,0 visibility conditions at any airfield in the United States. A real beam image of the airfield is produced which looks the same in the radar domain whatever the prevailing weather conditions.



Radar image



Visual image

The ALG clearly reveals airfield features and is particularly important in foggy conditions by maintaining runway capacity and aiding taxiing so that the airport can continue to operate without the cancellation of flights. The ALG uses a derivative of the mmW RF seeker with a replacement antenna and different software and is generally mounted in the radome of the aircraft.

Additional applications

The same basic equipment can also be used for ground surveillance or on boats for military, quasi-military and commercial applications including:

- ▶ Military aircraft
- ▶ Commercial aircraft
- ▶ Special forces
- ▶ Surveillance for peace keeping and law enforcement operations
- ▶ Coastguard
- ▶ Search and rescue
- ▶ Luxury yachts

Landing in brown-out conditions

Helicopter landing in dust or sand (brown-out conditions) is highly dangerous, especially where the dust is particularly fine and pervasive.



A derivative of the mmW RF seeker hardware architecture, with only software changes, provides pilots with situational awareness even in the worst conditions. The device is compact and lightweight but, most importantly, is available virtually off-the-shelf.

Security turnstile

A rapid throughput security turnstile system incorporating an imaging radar, based on seeker hardware but with a different antenna and software, monitors personnel for weapons etc. Applications for this device include monitoring people entering:

- ▶ Sports stadia (e.g. Olympic Games)
- ▶ Underground / Metro
- ▶ Airport security
- ▶ Sensitive buildings

In order to achieve fast crowd throughput, the design objective is to use turnstiles similar to current standards and for the scan to be completed in <2 seconds in order to maintain an adequate flow of people, even in the busiest conditions.



Precision Solutions

PB75A, MBDA UK, Six Hills Way
Stevenage, SG1 2DA. UK

Tel: +44 (0)1438 754477

Fax: +44 (0)1438 755198

e-mail: precision.solutions@mbda.co.uk

www.mbdaps.com

▶ **For rates and availability, contact Precision Solutions on +44 (0)1438 754477 or email: precision.solutions@mbda.co.uk www.mbdaps.com**