



Global Energy
Systems

GREAT BRITISH ENERGY. NATURALLY

AIR SOURCE
HEAT PUMPS

KEEPING YOU WARM FOR LESS

RHI
Now Available

How it Works

Air Source Heat Pumps

The commonest form of heat pump is a fridge; the heat that you feel on the back of a fridge is produced by the same process as is used in an air source heat pump. A refrigerant that boils at -40°C is pumped through an evaporator (see 1 in the diagram), a fan draws the air across the evaporator and the refrigerant boils, taking energy out of the air which will be used for your heating and hot water. This newly boiled gas, along with the energy that it has harvested, is then pressurised by a compressor (see 2 in the diagram), forcing its temperature up and creating useable heat for your property. The heat is then transferred into your heating and hot water system through a heat exchanger (see 3 in the diagram) and travels off to your radiators and/or under floor system and hot water cylinder. The now cooled refrigerant is allowed to expand again, drops in pressure and returns to a liquid ready to start the process again (see 4 in the diagram).

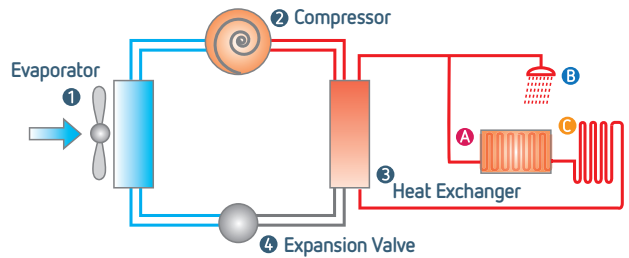

A Central Heating **B** Domestic Water **C** Under Floor Heating (If present)



Heat and Power System Combined with Solar PV

Great British Engineering

Built here in the UK each Eco Air Boiler is a masterpiece of Great British engineering. Built under precision engineering conditions and individually tested, each heat pump leaves with our seal of approval.

Global Energy Systems' design team have created a high performance heat pump that sets us apart from the air conditioning unit driven market. Designed and built as a heat pump the Eco Air Boiler is made to be different from the rest.

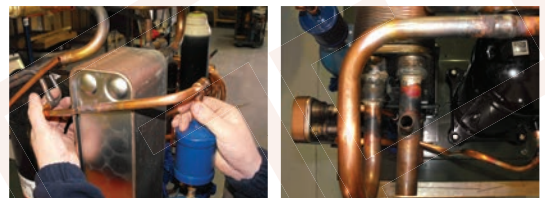

A quality engineered air source heat pump built in the United Kingdom

The Eco Air Boiler Difference

The simple reliability of a fridge has been re-engineered by Global Energy Systems for the Eco Air Boiler range. Uniquely able to offer domestic hot water at up to 70°C whilst also providing central heating, the Eco Air Boiler has been designed to be most effective in the UK's cool, damp climate. The heat exchangers, compressor, evaporator and layout of the heat pump have all been engineered for many years of reliable, renewable energy.

Global Energy Systems supply complete, integrated systems with heat pumps, cylinders and sensors optimised to work together, all controlled through our own software and touch screen. Each heat pump is connected remotely to our head office allowing its performance to be monitored and optimised and you to access your heating bills and settings on line.

A Quality Masterpiece Through Innovation Delivering Tomorrow's Technology Today



Reliable Air Source Heat Pumps. Cut your bills and earn RHI

Global Energy Systems prides itself on a AAA rating, manufacturing and customer service

The Eco Air Boiler Features

- ✓ Designed for the UK climate down to -20°C
- ✓ Produces domestic hot water at up to 70°C
- ✓ High mounted evaporator to prevent cold air recirculation
- ✓ High speed defrosts with start/stop sensor
- ✓ Data link for real time monitoring
- ✓ Personal energy portal with bills and usage
- ✓ Remote internet control function
- ✓ Unique performance optimisation service
- ✓ SAP Appendix Q listed for building regulations
- ✓ British designed and built
- ✓ Simultaneous hot water and heating
- ✓ Coefficient of performance of 3.0 at -7°C
- ✓ Built for 25 years of reliable, renewable energy
- ✓ Touch screen controller with simple controls
- ✓ All electronic components in sealed enclosures
- ✓ Integrated, complete system from one source
- ✓ Designed to work with radiators and underfloor heating systems
- ✓ Ideal for replacing Oil/LPG/Electric or Gas boilers
- ✓ MCS accredited for grants and subsidies
- ✓ Ideal for use with solar PV for free heating
- ✓ Eligible for Renewable Heat Incentive

*Note not all features are available on all heat pumps.

The Eco Air Boiler System

Eco Air Boiler



Products Available

- 9kW London
- 15kW Stirling
- 23kW Edinburgh
- 45kW York
- 140kW Cambridge

A range of heat pumps suitable for all sizes of properties.

Eco Store



High performance water cylinders optimised for our heat pumps. Options for all hot water and heating systems.

Eco Touch



Easy to use, touch screen controller with thermostat control, 7 day scheduler, holiday mode and software to integrate with existing heating systems. Offers full system status information on screen.

Eco Link



Live data link offering monitoring and optimisation of your heat pump by our engineers. Eco Link also offers you the ability to control your heating and view fuel usage on your personal web page, accessible through phones or computers.

For more information visit www.globalenergysystems.co.uk or call +44 (0) 3333 444 414



Certificate Number MCS 1453
Heat Pump Technology





ECO LINK SERVICE

At Global Energy Systems we are dedicated to providing an outstanding product and customer service. Upon purchasing a heat pump we provide a number of features to ensure you get the most out of your product. We do this with the use of our services team, the eco link portal and the eco link display installed in your property.

Our dedicated services team will remotely monitor your heat pump to ensure it is working to the highest of standards. The services team receive a graph daily showing your heat pump usage and performance, from the data received potential issues can often be detected.



Benefits

- ✔ Free 3 year subscription
- ✔ Heat pumps performance monitored daily to ensure optimum use
- ✔ The majority of heat pump issues are detected promptly can be resolved before any problems arise
- ✔ Telephone support for any questions or issues
- ✔ Holiday mode



With our eco link subscription you will have access to your own online management portal; this is a very beneficial feature and can be accessed from any device connected to the internet. The portal allows you to keep track of your heat pumps settings and running costs, even when away from home.

We install the eco link display alongside your heat pump. It can be fitted to any room in your property. The display is touch screen and provides full control of the heat pump. It can be used to monitor the system and alter any settings.



- ✔ Allows you to monitor your energy data and usage
- ✔ Indoor and outdoor temperatures can be monitored
- ✔ 7 day central heating scheduler can be setup

For more information visit www.globalenergysystems.co.uk or call +44 (0) 3333 444 414





Residential

Revolutionary Heating & Hot Water Technology

Reliable Air Source Heat Pumps. Cut your bills and earn RHI

Air Source Heat Pumps are a very reliable low cost method of heating a residential property. Our system easily connects to your existing central heating system and gives you comfortable heating along with plenty of domestic hot water.

Global Energy Systems have developed our unique Air Source Heat Pump to work in temperatures as low as -20°C, whilst supplying high grade hot water up to 70°C. One of our unique features allows you the ability to run your central heating system at the same time as heating hot water. Our customers enjoy feeling the benefits of warmth whilst saving up to 65% compared to some fuels.

Global Energy Systems have also developed an easy to use colour touch screen interface with a remote link which connects each system to our Head Office. Customers now have the ability to log on to their systems and see their running costs, as well as making any changes to their heating and hot water requirements. This unique system allows the homeowner the ability to log on with a computer or mobile phone whilst you are away from your home.

Key Benefits

- ✓ Reduce your heating bills by up to 65% and earn Renewable Heat Incentive for 7 years
- ✓ Simultaneous production of hot water and central heating
- ✓ Built-in remote monitoring service
- ✓ Check your system, data costs, graphs and statistics online
- ✓ Colour touch-screen controller with time scheduler
- ✓ Zero emissions on site
- ✓ Easy to install and retrofit to existing systems

Our Air Source Heat Pumps are perfect for...



Heat Pump Range

- 9kW London
- 15kW Stirling
- 23kW Edinburgh
- 45kW York



GREAT BRITISH ENERGY. NATURALLY



“ We reduced our heating bills from £4,000 to £1,800 pa ”



Savings

Electric	LPG	Oil
£5,000	£2,800	£2,400

Based on 36,363 kWh annual heat demand.
RHI payments assumed.

For more information visit www.globalenergysystems.co.uk or call +44 (0) 3333 444 414



Certificate Number MCS 1453
Heat Pump Technology



Not all features are available on all heat pumps. All estimates and savings correct at time of calculation.

RENEWABLE
HEAT INCENTIVE
NOW AVAILABLE



2.5p/kWh for 20 years

Commercial

Revolutionary Heating & Hot Water Technology

Reliable Air Source Heat Pumps. Cut your bills and earn RHI

Heat pumps are becoming more and more widespread as people's knowledge of renewable energy expands from electricity to heat. Heating and hot water can be one of the heaviest uses of energy in commercial buildings, especially where heat is needed all year round. Offering RHI income, cost savings of up to 65% and demonstrating real carbon reduction, heat pumps have a key part to play in keeping our future warm, helping to meet emissions targets and saving money on ever rising energy bills.

Air source heat pumps can provide full heating solutions for most buildings through radiators, underfloor heating or blown heat. They are also particularly suited to year round heat needs such as swimming pools.

As part of an integrated, multi-fuel system they can offer pre-heat for high grade water heat or controlled as part of building management system to combine several heat sources in optimum balance.

Suitable for a full range of buildings from new builds to listed heritage properties, heat pumps offer a simple, reliable, easy to install alternative to the costs and emissions of fossil fuels.

Through our Eco Link real time online monitoring service, we can provide energy analysis and management data for emissions monitoring as well as information for ISO accreditation. We can also provide centralised data, billing and remote operation for multiple sites with bespoke energy metering services.

Key Benefits

- ✓ Single unit solutions up to 140kW
- ✓ Remote monitoring and optimisation service
- ✓ Online emissions and costs tracking
- ✓ Bespoke software for multi-fuel systems
- ✓ Integrate with existing heating systems
- ✓ Cut bills by up to 65% and earn RHI for 20 years to get 90% savings
- ✓ Zero emissions on site

Our Air Source Heat Pumps are perfect for...

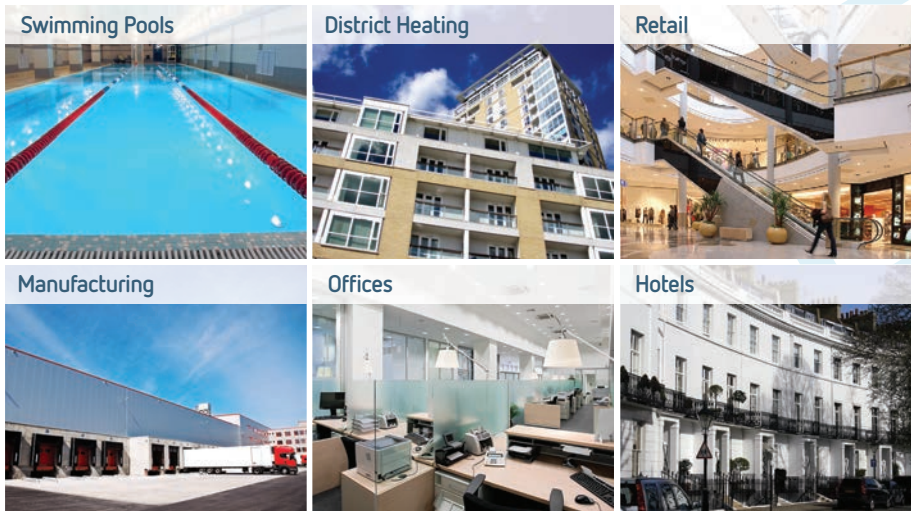

Heat Pump Range

- 9kW London
- 15kW Stirling
- 23kW Edinburgh
- 45kW York
- 140kW Cambridge

RENEWABLE
HEAT INCENTIVE
NOW AVAILABLE



2.5p/kWh for 20 years

LEISURE CENTRE WITH 2 X YORK 45kW

SAVE A HUGE 90% ON YOUR HEATING BILLS

FOR EACH £10,000 YOU SPEND WE WILL SAVE YOU

SAVE GAS
£8,700

SAVE LPG
£9,400

SAVE OIL
£9,200

SAVE ELECTRIC
£9,600



2 X YORK 45kW
IN MULTI-FUEL SYSTEM



WAREHOUSE HEAT DELIVERY

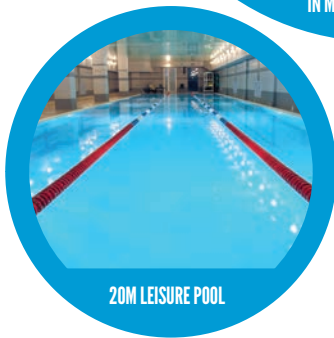

20M LEISURE POOL



NEW CAMBRIDGE 140kW



3500m² WAREHOUSE

For more information visit www.globalenergysystems.co.uk or call +44 (0) 3333 444 414



Certificate Number MCS 1453
Heat Pump Technology



All estimates and savings correct at time of calculation.



Agricultural

Revolutionary Heating & Hot Water Technology

Reliable Air Source Heat Pumps. Cut your bills and earn RHI

Heat pumps are used for heating and hot water which can be the heaviest uses of energy on a farm, especially where heat is needed all year round. Offering both substantial cost savings of up to 65% and demonstrating real carbon reduction, heat pumps have a key part to play in the food supply chain.

Global Energy Systems' heat pumps are well suited to all year round heating down to as low as -20° C . Thus they are ideal for farrowing, weaning, fish rearing, propagation and are very effective for heating water for hot washes in dairies. They have been used for many years in commercial and domestic properties for both heating and hot water.

All our heat pumps are supplied with easy to use control and information functions which are viewable on-line, allowing remote control and monitoring via computer or mobile phone.

Global Energy Systems' air source heat pumps have the capability to deliver domestic hot water up to 70° C at the same time as supplying the central heating.

Key Benefits

- ✓ Reduce your heating bills by up to 65% and earn Renewable Heat Incentive for 20 years
- ✓ Single unit solutions up to 140kW
- ✓ Built-in remote monitoring service
- ✓ Check your system, data costs, graphs and statistics online
- ✓ Colour touch-screen controller with time scheduler
- ✓ Zero emissions on site
- ✓ Very easy to retrofit to existing systems

Our Air Source Heat Pumps are perfect for...

Underfloor heating for broiler sheds	Heating for weaner sheds	Heating for farrowing crates
		
Warm water for fish farming	Horticultural farming	Hot water for milking parlours
		

Heat Pump Range

- 9kW London
- 15kW Stirling
- 23kW Edinburgh
- 45kW York
- 140kW Cambridge
- 8-18 kW Caernarfon

Weaning and Farrowing Sheds

Global Energy Systems have been working closely with agricultural farmers for a number of years, providing great savings with air source heat pumps and their built in control strategies.

Being required all year round, heating for hot water can be the heaviest use of energy on a farm. Cutting this cost is essential for famers.

We have seen great savings made by our customers along with significant RHI incentive payments, together providing huge financial benefits to our customers.

CASE STUDY 1

- ✓ 90 Crate Farrowing Building
- ✓ Heat pads with under-floor Heating
- ✓ 2x York Eco Air Boilers
- ✓ RHI Accredited Installation
- ✓ Current Annual Running Cost with ASHP £8,000
- ✓ SCOP 2.8
- ✓ £5,000 per year saving on Previous Heating System
- ✓ £5,000 RHI Payments
- ✓ Over £10,000 saving per year on Previous Heating Systems
- ✓ 4.3 year payback period with additional 15 years RHI payment incentive



CASE STUDY 2

- ✓ 64 Crate Farrowing and Weaning Building
- ✓ Heat pads with under-floor Heating
- ✓ 1x York Eco Air Boilers 1x Edinburgh
- ✓ RHI Accredited Installation
- ✓ Current Annual Running Cost with ASHP £6,000
- ✓ SCOP 3.1
- ✓ £2,000 per year saving on Previous Heating System
- ✓ £4,000 RHI Payments
- ✓ Over £6,000 saving per year on Previous Heating Systems
- ✓ 3.7 year payback period on installation with additional 16 years RHI payment incentive

These two installations were both built, installed and accredited between 2015 and 2016. With alternative options such as oil, LPG and direct electric heaters available, the customers decided to install Global Energy Systems air source heat pumps. Both installs are wet systems designed for under floor fed heat pads.

The ever growing relationship Global Energy Systems has with key building and heating suppliers for farrowing and weaning houses has led to a number of further installations of a similar nature. These too are providing customers with great savings and RHI incentive payments.

For more information visit www.globalenergysystems.co.uk or call +44 (0) 3333 444 414



MCS HP0010



Certificate Number NIC 5608
Heat Pump Technology





Datasheet London

Air Source Heat Pump		
Product Name		London Eco Air Boiler
Model Number		LNDSHR407CDHW70C
(Air 7°C/Water 35°C)*	Rated Output (kW)	6.9
	Power Consumption (kW)	2.1
	Rated COP	3.3
(Air 2deg.C/Water 35°C)**	Rated Output (kW)	5.9
	Power Consumption (kW)	2.0
	Rated COP	3.0
(Air -7°C/Water 35°C)**	Rated Output (kW)	4.9
	Power Consumption (kW)	1.8
	Rated COP	2.7
Domestic Hot Water Temperature (°C)		70
Weight (kg)		200
Heat Pump Voltage/frequency		220/240V 1~ 50Hz
Heat Pump Maximum Running Current (A)		15
Sound Power Level @ 1m (dB)**		65
Minimum Operating Temperature (°C)		-20
Maximum Operating Temperature (°C)		30
Booster Heater Running Current (A)		27

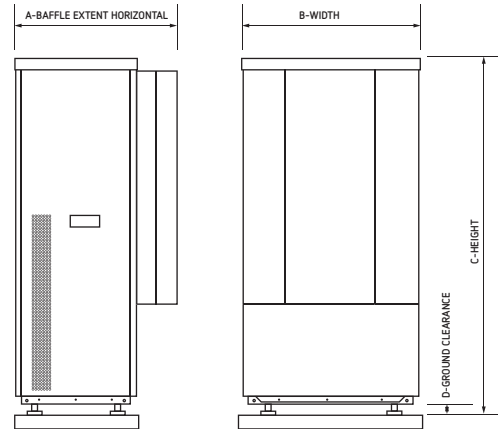

Model	A	B	C	D
London	800	800	1590	50-70

All sizes in mm

* Test results as per BS EN14511 ** Data supplied by BRE

Output

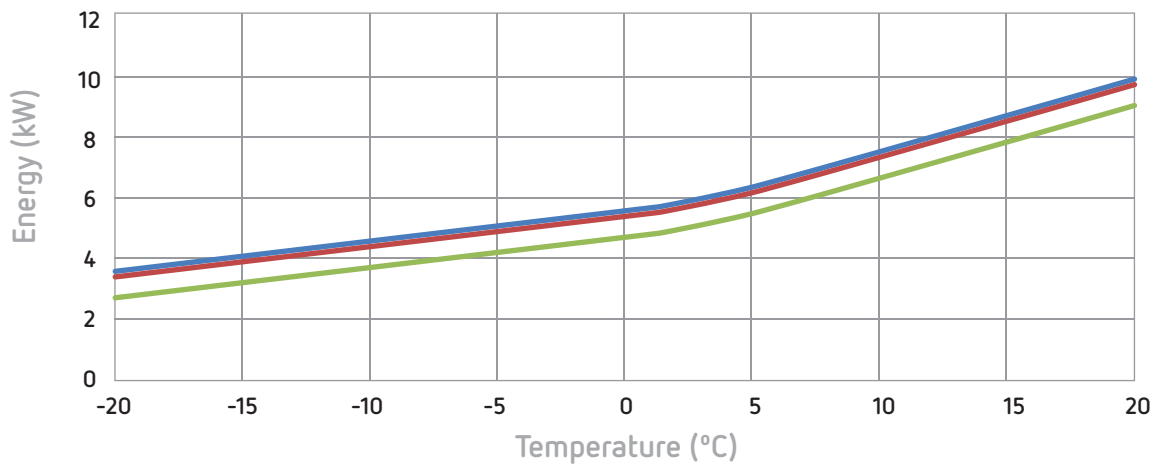

COP

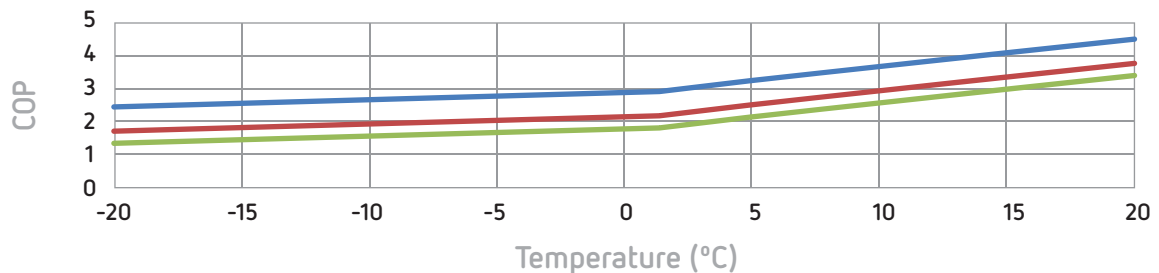

Case Study 1

- ✓ 185 m² new build
- ✓ UFH throughout
- ✓ 1 x 9 kW London Eco Air Boiler
- ✓ Running costs estimate 2014 £726
- ✓ Savings estimate with RHI £1,100
- ✓ RHI eligible

New Build with Underfloor Heating

This 185 m² new build does not have mains gas available and thus would have had to install an oil or LPG system. In choosing a heat pump they have removed their exposure to the rising price of oil and made their planning permission easier.

With a full under floor heating system both up and down stairs the property can run on low flow temperatures offering excellent savings. The heat pump is controlled by the UFH system and the Global Energy Systems software ensures the most efficient running. Even with temperatures as low as -13°C in 2013 the property was warm. In these extreme conditions the heat pump used its built in booster heater when needed.

The heat pump has been stood away from the house wall to allow access and low loss underground pipes were used to transfer the heat efficiently into the building.

Having moved from a house with oil as the main fuel the owners have been amazed at the running costs.



Case Study 2

- ✓ Indoor Swimming Pool
- ✓ Lancashire
- ✓ 10m x 4m indoor pool and hot tub
- ✓ 1 x 9kW London Eco Air Boiler
- ✓ Running cost estimate 2014: £1,200
- ✓ Savings estimate v's oil: £600

Indoor Swimming Pool

This new build project wanted to run their pool 12 months a year without the exposure to the cost of standard heating methods. The pool is used daily and is covered whenever not in use to ensure that energy is not lost unnecessarily.

The single London 9kW Eco Air Boiler is located in the plant room drawing the air from the pool room. This recycles lost heat from the pool, captures any solar gain and acts as a dehumidifier when the heat pump is running.

Heating costs have averaged £100 a month since the installation of the heat pump, this includes hot water for the house and heating for the pool room.

When asked to comment they said that they were "Delighted" with the system.

Case Study 3

- ✓ Rural Farmhouse
- ✓ Lancashire
- ✓ 3 bed, Victorian brick farmhouse
- ✓ 1 x 9kW London Eco Air Boiler
- ✓ Running costs estimate: 2014 £935
- ✓ Savings v's oil with RHI £1,400
- ✓ Cold air ducting for garage location

Rural Farmhouse

Set in rural Lancashire with no access to mains gas the owners of this farm house wanted to escape their dependence upon oil.

The installation of a London Eco Air Boiler has reduced their annual heating and hot water bill to £935 in 2014 from £1,938 in 2011.

The Eco Air Boiler has been installed at the rear of an open garage with the cold air being ducted out through the roof. This allowed the secluded rear garden and flower beds to remain undisturbed and offered a simple link into the existing heating system through the house wall. Several radiators in the house were upgraded to ensure all rooms were able to reach the desired temperature using a heat pump.

The owners have commented that they have been very happy with the savings.



For more information visit www.globalenergysystems.co.uk or call +44 (0) 3333 444 414



Certificate Number MCS 1453
Heat Pump Technology



ErP **A++**

DATASHEET CAERNARFON

Air Source Heat Pump

Product Name		Caernarfon
Model Number		CAER410AMOD1
ERP Rating		A++
(Air 7°C/Water 35°C)*	Rated Output (kW)	8.58
	Power Consumption (kW)	1.80
	Rated COP	4.76
(Air 2°C/Water 35°C)**	Rated Output (kW)	10.92
	Power Consumption (kW)	3.36
	Rated COP	3.25
(Air -7°C/Water 35°C)**	Rated Output (kW)	12.13
	Power Consumption (kW)	4.53
	Rated COP	2.68
Domestic Hot Water Temperature (°C)		65
Weight (kg)		230
Heat Pump Voltage / Frequency		230V AC 50Hz
Max Running Current (A) Compressor / Booster		34/27
Max Electrical Power (kW) Compressor / Booster		8.2/6.0
Sound Pressure Level @ 1m (dBA)***		54
Minimum/Maximum Operating Temperature (°C)		-20/30
Maximum Starting Current (A)		14.3

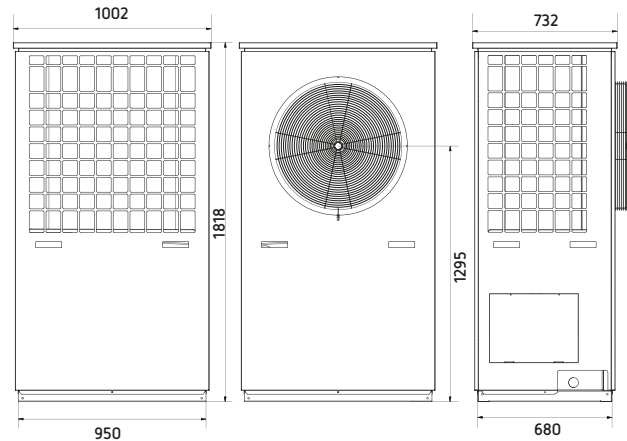

Model	H	W	D
Caernarfon	1818	1002	732

All sizes in mm

* Test results as per BS EN14511 ** Data supplied by BRE

*** Sound power level is 61.5 dBA as tested to BS EN12102

Caernarfon Performance at 55°C Outlet Temperature

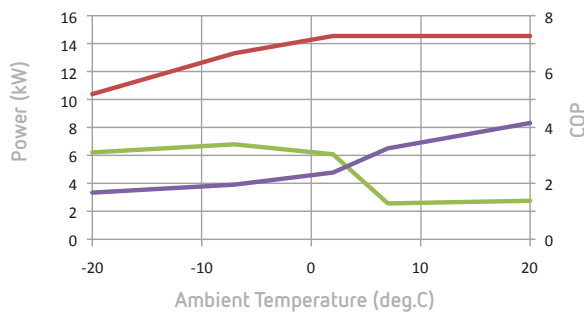

Caernarfon Performance at 35°C Outlet Temperature

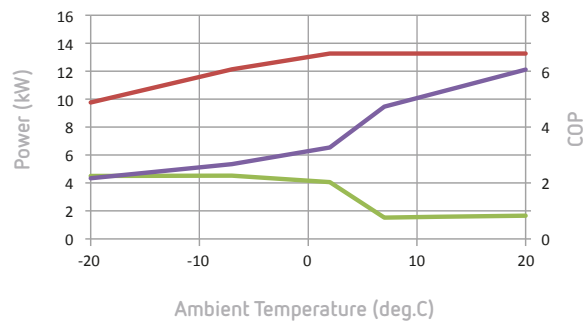

— Power Output (kW) — Power Input (kW) — COP

THE CAERNARFON IS IDEAL FOR...

DOMESTIC NEW BUILDS

The variable output of the Caernarfon 8-18kW air source heat pump offers complete heating and domestic hot water solutions for even the largest new build properties. With run costs savings of up to 70% and the Renewable Heat Incentive available to self-builders, the Caernarfon is an ideal solution for new builds.

Integrating a Caernarfon air source heat pump in a new build project could not be easier. Our specifiers and engineers will recommend suitable heat emitters for each room. The Caernarfon is designed to work equally effectively with under floor or radiator based systems with an A++ ERP rating. Requiring only an electric power supply, the use of a Caernarfon simplifies utility connections and future energy bills



DOMESTIC RETRO FITS

Offering our highest heat output from a single electricity supply, and inverter control to vary the heat pump output, the Caernarfon 8-18kW air source heat pump has been engineered with British houses in mind. Working equally well with under floor heating or radiators the Caernarfon offers the flexibility to work with existing systems.

Able to offer full heating and domestic hot water supply to large, retro fit properties, the Caernarfon is an ideal choice for renovation projects. Through bespoke software, written by Global Energy Systems, the Caernarfon can either work bivalently with an existing boiler or replace it completely in line with RHI guidelines.

POOLS

Swimming pools, with their potential need for year round, low grade heat are an ideal match for air source heat pumps. The Caernarfon 8-18kW air source heat pump, with its inverter technology and 55 °C output is a perfect match for pool water, space heating and domestic hot water combinations.

Able to work as a standalone unit, bivalently with boilers or in parallel with other units, the Caernarfon can be used for any scale of installation. Eligible for the Renewable Heat Incentive for Non-Domestic pools, the Caernarfon can offer excellent savings. The heat for domestic pools, when part of a wider heating system, can benefit from the savings of the Caernarfon but is not counted for the RHI.



SMALL COMMERCIAL

The Caernarfon 8-18kW air source heat pump offers the flexibility to deliver heat through existing radiators, under floor or fan convactor based heating systems. It has been specifically designed for the UK climate with a broad range of uses.

Able to deliver space heating to single, large spaces such as workshops or halls, heat to hotel or residential rooms and domestic hot water to legionella standards, the Caernarfon is an ideal choice. Able to work as a standalone unit, bivalently with boilers or in parallel with other units, the Caernarfon can be used for any scale of installation.

MULTIPLE UNITS

As heat loads increase, multiple Caernarfon air source heat pumps can be used together to offer solutions to very large heat loads. Suitable for large warehouses, workshops, hotels, pools or offices the Caernarfon is an ideal choice.

Software developed by Global Energy Systems to work with our own air source heat pumps will ensure that the load is managed across the season and across the multiple heat pumps, offering an optimal solution.



For more information visit www.globalenergysystems.co.uk or call +44 (0) 3333 444 414





Datasheet Stirling

Air Source Heat Pump		
Product Name		Stirling Eco Air Boiler
Model Number		STRSHR407CMOD1
(Air 7°C/Water 35°C)*	Rated Output (kW)	12.7
	Power Consumption (kW)	3.6
	Rated COP	3.6
(Air 2°C/Water 35°C)**	Rated Output (kW)	11.0
	Power Consumption (kW)	3.3
	Rated COP	3.4
(Air -7°C/Water 35°C)**	Rated Output (kW)	9.6
	Power Consumption (kW)	3.2
	Rated COP	3.0
Domestic Hot Water Temperature (°C)		70
Weight (kg)		330
Heat Pump Voltage/frequency		220/240V 1~ 50Hz
Heat Pump Maximum Running Current (A)		25
Sound Power Level @ 1m (dB)**		67
Minimum Operating Temperature (°C)		-20
Maximum Operating Temperature (°C)		30
Booster Heater Running Current (A)		27

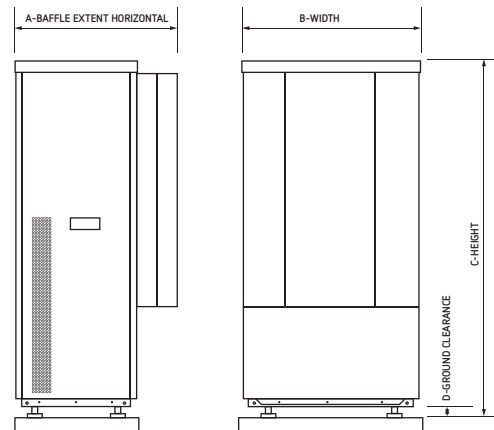

Model	A	B	C	D
Stirling	1120	980	1940	50-70

All sizes in mm

* Test results as per BS EN14511 ** Data supplied by BRE

Output

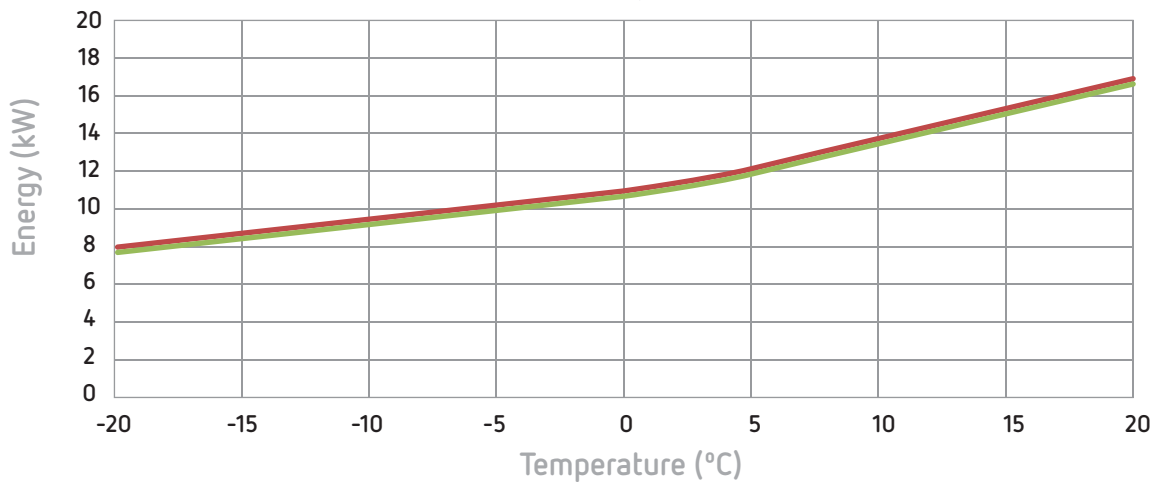

COP

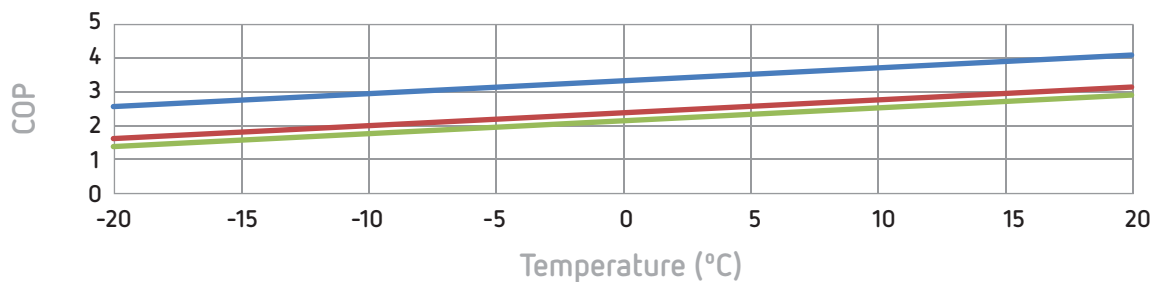

Case Study 1

- ✓ Renovated stone cottage
- ✓ 283m², 4 bed home
- ✓ 1 x 15kW Stirling Eco Air Boiler
- ✓ Running costs estimate 2014: £1,875
- ✓ Savings estimate v's oil with RHI £2,000

Renovated Stone Cottage

Renovated in 2012 this stone cottage in Scotland faced the prospect of installing an oil heating system unless an alternative could be found. After extensive research the owners settled on a Stirling 15kW Eco Air Boiler. This offered them a renewable, affordable system for the whole house.

The heat pump has been located in an out building. The Eco Air Boiler has been engineered to operate with ducted air flows, this allows both the intake and exhaust air to be drawn in from roof vents, allowing indoor installation.

The bills for the property in 2014 are estimated to be £1,875 a potential saving of up to £2,000 against oil if the RHI was claimed. The Eco Link energy portal has allowed the owners to monitor and understand their bills in the first year in their new home.



Case Study 2

- ✓ Barn Conversion - Carbon Neutral
- ✓ Trough of Bowland
- ✓ Barn conversion with PV installation
- ✓ 1 x 15kW Stirling Eco Air Boiler
- ✓ Annualised cost estimate: £0
- ✓ Savings estimate v's Oil: £2,500

Carbon Neutral Conversion

When converting this barn the owner wanted a carbon and cost neutral heating system. By combining a Stirling Eco Air Boiler with 20 solar PV panels the property is able to generate enough electricity to offset the heating on most days of the year. Our estimate of the savings compared to heating the property with oil is at least £2,500.

This combination, a heat and power system, offers the ultimate in cost and emissions savings. Global Energy Systems can work with you to design a balanced combination of heat pump and solar electric to give you the perfect outcome.

The owner commented that finding a combination of renewable sources to run his property in a sustainable and affordable manner has been a major benefit.

Case Study 3

- ✓ Victorian Semi Detached Home
- ✓ Fylde Coast
- ✓ 5 bed property with good insulation
- ✓ 1 x 15kW Stirling Eco Air Boiler
- ✓ Annualised cost Estimate: £2,100
- ✓ Savings estimate v's Oil: £2,250

Victorian Semi

Along with a large kitchen extension and eco upgrade the owners of this large semi-detached Victorian property on the Fylde Coast changed over to a 15kW Stirling Eco Air Boiler. The property used gas previously and had a bill of over £3,000 a year, showing an excellent saving even against mains gas.

The house has a mixture of recently upgraded radiators and under floor heating all controlled through the Eco Air Boiler. A single 15kW Stirling Eco Air Boiler has provided all the heating and hot water for the property at an average of under £100 a month.

"Our bills are far lower than expected and we were warm right through the winter" commented the owners.



For more information visit www.globalenergysystems.co.uk or call +44 (0) 3333 444 414



Certificate Number MCS 1453
Heat Pump Technology





Datasheet Edinburgh

Air Source Heat Pump		
Product Name		Edinburgh Eco Air Boiler
Model Number		EDSHR407CMOD1
(Air 7°C/Water 35°C)*	Rated Output (kW)	15.4
	Power Consumption (kW)	4.6
	Rated COP	3.4
(Air 2°C/Water 35°C)**	Rated Output (kW)	13.3
	Power Consumption (kW)	4.5
	Rated COP	3.0
(Air -7°C/Water 35°C)**	Rated Output (kW)	12.1
	Power Consumption (kW)	4.4
	Rated COP	2.8
Domestic Hot Water Temperature (°C)		70
Weight (kg)		330
Heat Pump Voltage/frequency		400/415V 3~ 50Hz
Heat Pump Maximum Running Current (A)		12
Sound Power Level @ 1m (dB)**		68
Minimum Operating Temperature (°C)		-20
Maximum Operating Temperature (°C)		30
Booster Heater Running Current (A)		27

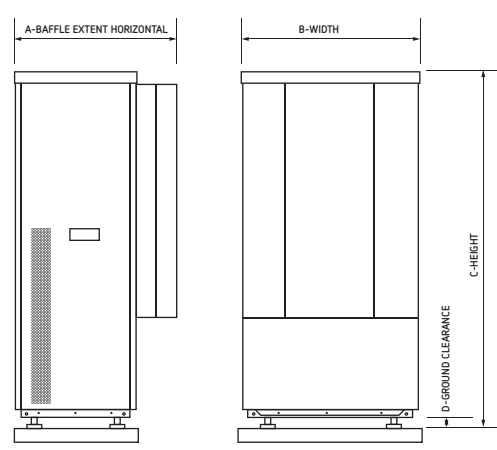

Model	A	B	C	D
Edinburgh	1120	980	1940	50-70

All sizes in mm

* Test results as per BS EN14511 ** Data supplied by BRE

Output

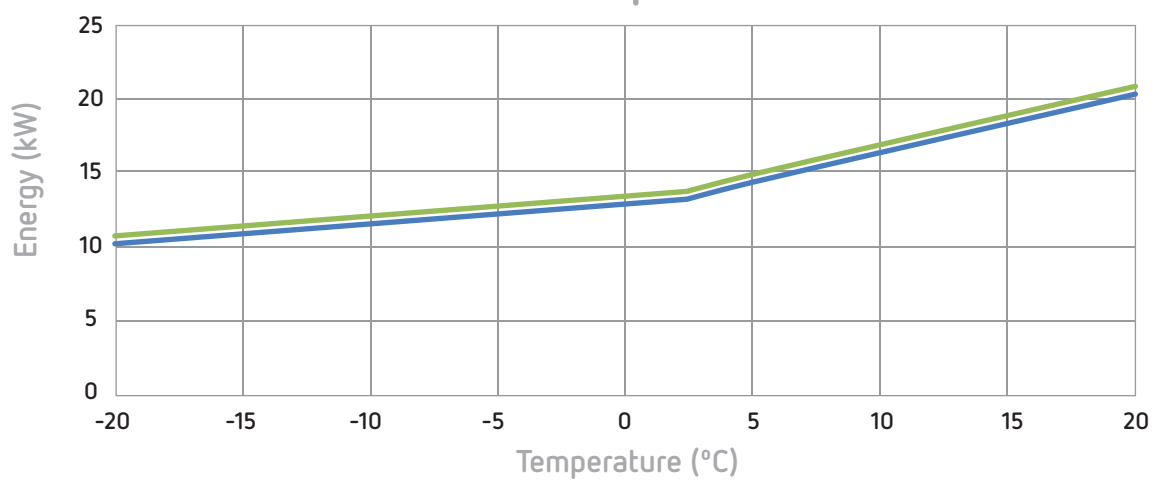

COP

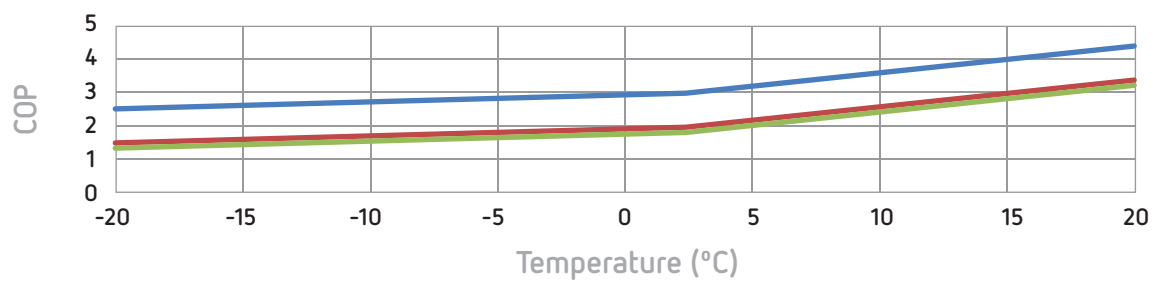

— 35°C — 55°C — 57°C



GREAT BRITISH ENERGY. NATURALLY

Case Study 1

- ✓ New Commercial Offices
- ✓ Lancashire
- ✓ Mixed use commercial building
- ✓ 1 x 23kW Edinburgh Eco Air Boiler
- ✓ Annualised cost estimate: £2057
- ✓ Savings estimate v's oil £1800 with RHI

Commercial Offices

At 4000sqft with a mixed use of manufacturing and offices this development wished to offer low cost and low emissions heating. In using a heat pump the emissions of the building will be capped, meaning that it is protected from future carbon levies.

A single 23kW Edinburgh Eco Air Boiler located in the plant room provides the heating and hot water for the building. Convecter heaters are used through out offering quick warm up times.

The building was commissioned with the Eco Air Boiler in place and has run happily through both recent winters offering a cost effective and low carbon solution.



Case Study 2

- ✓ Architectural New Build
- ✓ Lancashire
- ✓ 1 x 23kW Edinburgh Eco Air Boiler
- ✓ Annualised cost estimate: £2552
- ✓ Savings estimate v's oil with RHI £2300

Architectural New Build

Built to exacting architectural standards this large, stylish property's owners wanted to avoid exposure to the potential costs of oil fired central heating.

The house uses a combination of under floor heating and radiators and a 23kW Edinburgh Eco Air Boiler to provide central heating and hot water. Annual bills are predicted to be £2500 offering a saving of 55% against oil.

The new owners have commented that they are very happy with the system and are far more relaxed in their new home knowing that they are protected from potential rises in the costs of oil.

Case Study 3

- ✓ 400m² Sustainable Food Production
- ✓ Incredible Edible Project
- ✓ 2 x Edin 23kW units
- ✓ Annual running costs 2014 £3000
- ✓ Annual Carbon load 2014 12,000kg

Sustainable Food Project

The Incredible Aquagarden is part of the Incredible Edible Todmorden project, setting out to both grow sustainable food and teach sustainability to the local community.

The 400m² building houses aquaponic and hydroponic growing systems producing a range of fruit and veg. From the outset the project tried to minimise its carbon foot print.

2 Edinburgh heat pumps were chosen to offer low carbon heating and hot water for the project and zero emissions on site. In 2014 the site used £250 a month of electricity and generated approximately 1000kg of carbon per month. This 400m² building has added the carbon footprint of just one and a half average UK citizens.



For more information visit www.globalenergysystems.co.uk or call +44 (0) 3333 444 414



Certificate Number MCS 1453
Heat Pump Technology



ErP

A⁺

DATA SHEET YORK

Air Source Heat Pump

Product Name	York	
Model Number	YRKR407CM0D1	
ERP Rating	A+	
(Air 7°C/Water 35°C)*	Rated Output (kW)	33.6
	Power Consumption (kW)	10.4
	Rated COP	3.2
(Air 2°C/Water 35°C)*	Rated Output (kW)	29.4
	Power Consumption (kW)	10.2
	Rated COP	2.9
(Air -7°C/Water 35°C)*	Rated Output (kW)	25.2
	Power Consumption (kW)	10.3
	Rated COP	2.4
Domestic Hot Water Temperature (°C)	65	
Weight (kg)	500	
Heat Pump Voltage / Frequency	400/415V 3~ 50Hz	
Max Running Current (A) Compressor	30	
Max Electrical Power (kVA) Compressor	21.5	
Sound Power Level @ 1m (dB)*	84.3	
Minimum Operating Temperature (°C)	-20	
Maximum Operating Temperature (°C)	30	



Model	H	W	D
York	1944	2026	1006

All sizes in mm

* Test results as per BS EN14511

York Performance at 55°C Outlet Temperature

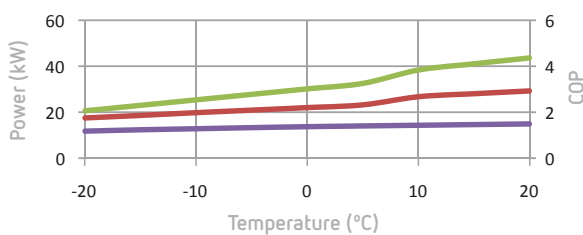

York Performance at 35°C Outlet Temperature

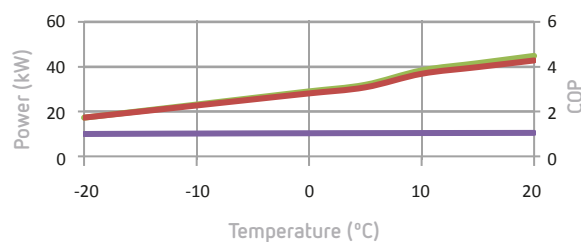

— COP — Power Output (kW) — Power Input (kW)

CASE STUDY 1

- ✔ 20m pool and facilities
- ✔ 2 x York 45kW
- ✔ 2015 estimated costs of heat pump £4000
- ✔ RHI eligible

LEISURE CENTRE DEVELOPMENT

In building this leisure centre the owners were keen to have as sustainable an energy requirement as possible. To this end, air source heat pumps have been installed in tandem with gas boilers and roof mounted PV panels. This allows the mixed demands of pool and space heating, along with shower water, to be managed across the year.

The PV panels offer a distinct income and offer large savings when they generate in tandem with the running of the heat pump. The gas boilers allow high temperature water on short notice and resilience in extreme weather.

2 York heat pumps are used, with the gas plumbed in after their flows and controlled by the heat pumps' performance.

In 2015 the heat pumps consumed 35,000kWh of electricity produced and just 16t of carbon emissions. The PV panel have the potential to fully offset this in an average year.



CASE STUDY 2

- ✔ 1 x York 45kW
- ✔ Oil annualised running cost £8,000
- ✔ Estimated savings £4,160



SCOTTISH COUNTRY HOUSE

This large, Scottish country house was spending £8,000 a year on oil. The owner wanted to both reduce the bill and remove their exposure to the price of oil rising in the future, a particular risk in rural areas where winter prices often spike.

The heating system has been designed to use a single York 45kW Eco Air Boiler. The oil boiler has also been retained and integrated into the system to offer additional output in extreme weather. This has created a bivalent heating system managed by Global Energy Systems' own software.

This balance of heat provision has almost cut the running bill in half. There were upgrades to the radiator system to ensure efficient running with a heat pump, but this was done with minimal disruption. The heat pump provides the full heating requirement of the property for the vast proportion of the year with the oil boiler, being used on extremely cold winter days.

CASE STUDY 3

- ✔ 700m² mixed use
- ✔ 2 x York 45kW
- ✔ Annualised run cost estimate £10,000
- ✔ Estimated Savings £7,000

LIGHT INDUSTRIAL UNIT

The recent redevelopment of this light industrial site has included the installation of 2 York 45kW Eco Air Boilers to supply the heating needs. The site has a mixture of offices, warehousing and production areas with varied heat demands. The flexibility of the two heat pump system is ideal for this diversity. Heat delivery is through a combination of radiators and ceiling fans with a low hot water use.

Full year running costs are not yet available but the annualised costs on LPG were over £17,000, offering potential savings in excess of £7,000 and emissions savings of 15,000kg of carbon.



For more information visit www.globalenergysystems.co.uk or call +44 (0) 3333 444 414

All estimates and savings correct at time of calculation.



DATA SHEET CAMBRIDGE

Air Source Heat Pump		
Product Name	Cambridge	
Model Number	CAM407CMOD1	
SSHEE (Ave conditions)	108%	
(Air 7°C/Water 35°C)*	Rated Output (kW)	82.5
	Power Consumption (kW)	25.1
	Rated COP	3.3
(Air 2°C/Water 35°C)*	Rated Output (kW)	79.3
	Power Consumption (kW)	27.6
	Rated COP	2.9
(Air -7°C/Water 35°C)*	Rated Output (kW)	67.3
	Power Consumption (kW)	26.0
	Rated COP	2.6
Domestic Hot Water Temperature (°C)	65	
Weight (kg)	1000	
Heat Pump Voltage / Frequency	400/415V 3~ 50Hz	
Max Running Current (A) Compressor	60	
Max Electrical Power (kVA) Compressor	54	
Sound Power Level @ 1m (dB)*	75	
Minimum Operating Temperature (°C)	-20	
Maximum Operating Temperature (°C)	30	

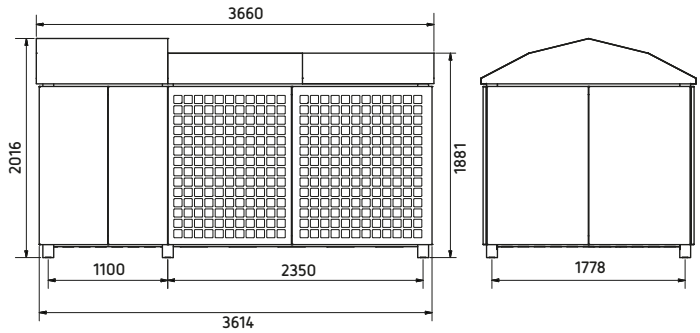

Model	H	W	D
Cambridge	1881	3660	1778

All sizes in mm

* Test results as per BS EN14511

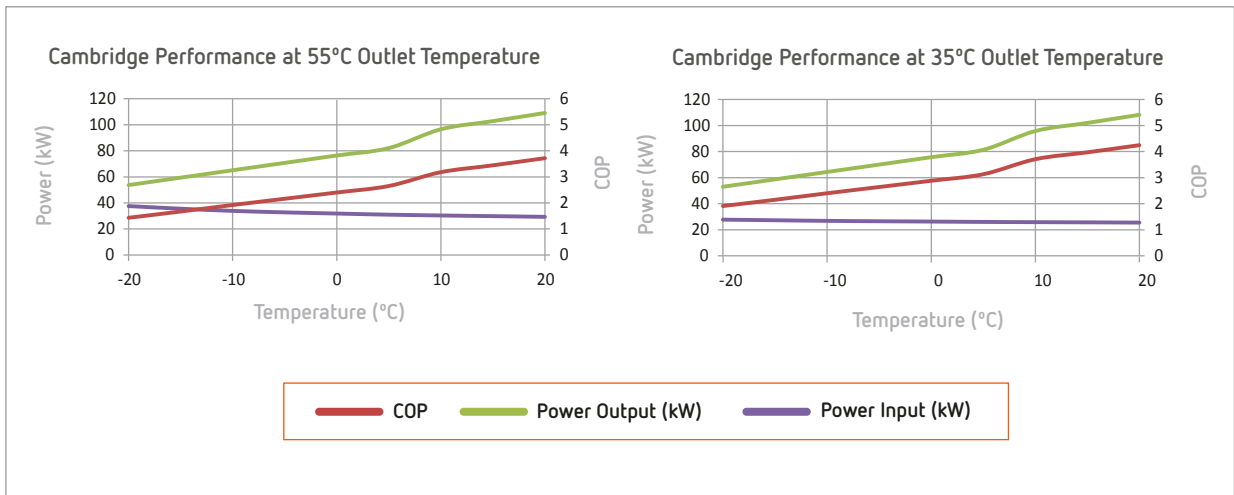

CASE STUDY 1

- ✔ Large commercial space
- ✔ 2015 running costs £8000
- ✔ 40% emissions reduction
- ✔ RHI eligible

3500M² WAREHOUSE

The owners of this 3500m² warehouse and production hall were looking to hold the space at a working temperature of 19°C and remove the existing gas system. Based on a heat loss survey, and the client's expected pattern of air change through the large doors, a single Cambridge 100kW unit was specified. The air source heat pump was coupled with easy to install and commission ceiling mounted fan convectors, allowing both heat delivery and an element of destratification. The fan convectors were specified to allow low flow temperatures maximising the system efficiency.

In 2015 running costs were estimated at under £8,000. With anticipated payments from the RHI, total savings are estimated at £9,750 at 2015 prices.

Carbon emissions are expected to fall by up to 40%.

The Client commented: "After a full year of running, including a spell of cold weather last winter, we have been impressed with the new system. Maintenance is low and running costs have been better than last year, even before taking into account the subsidies."



CASE STUDY 2

- ✔ Retro-fit school scheme
- ✔ Existing radiator system
- ✔ Gas boilers integrated
- ✔ RHI potential £8000 pa



VICTORIAN SCHOOL

Clarence High School have a large, Victorian building with an equally large, radiator based system. Seeking to both control costs and reduce emissions whilst benefiting from the RHI, they looked to an air source heat pump. Given the scale of the existing radiator system and the costs of a full overhaul, a Cambridge 100kW heat pump was specified in tandem with gas boilers. This bivalent system uses the heat pump for the full heating season, with the gas boilers controlled by the heat pump, boosting the system flow temperatures. The gas boilers are only used when the output of the heat pump is insufficient to meet the target temperatures.

With potential RHI payments of up to £8000 a year, the project was justified without the need to demonstrate large savings on running costs.

Carbon emissions are expected to fall by up to 25% on the heat generated by the heat pump.

For more information visit www.globalenergysystems.co.uk or call +44 (0) 3333 444 414

All estimates and savings correct at time of calculation.