

FlowPod Installation and Operating Instructions



INTRODUCTION

These instructions cover the installation and basic operation of the LM FlowPod series display instruments. All configuration and set-up is detailed in a separate manual, ref: LM0663.

Installation and operating instructions for the flowmeter will be separate from these instructions and should be consulted in addition to these instructions, along with relevant drawings where supplied.

Table of Contents

INTRODUCTION	1
CERTIFICATION STANDARDS	2
Conditions of Acceptability	2
Certificates	2
ENCLOSURE LABELS	16
LM CIFM-series Sensor (VFF) & Stand-alone Display	16
FlowPod Enclosure	16
Remote Enclosure (Remote Junction Box).....	16
KEM SV-series Sensor.....	17
FlowPod Enclosure:.....	17
Remote Junction Box	17
GENERAL INSTRUCTIONS	18
Cables and Glands	18
Grounding and Bonding Terminals	18
SAFETY PARAMETERS.....	19
Temperature	19
Power	19
Sensor	19
Electrical Connections:.....	19
Miscellaneous	19
INSTALLATION	20
Assembly & Disassembly.....	20
Direct-mount unit	20
Remote-mount unit	20
Field Connections.....	20
Terminal Board Layout Diagrams & Terminal Assignment	22

Litre Meter Ltd - Hart Hill Barn - Granborough Road - North Marston - Buckingham - MK18 3RZ
tel: +44(0)1296 670200 - fax: +44(0)1296 670999 - email: sales@litremeter.com - web: www.litremeter.com

Terminal Board (Rev. B)	22
Terminal Board (Rev. C)	22
Terminal Board (Rev. E)	23
Junction Box / Remote Terminal Boards (Rev. A)	23
Sensor connections	24
Display Orientation	24
Direct Mount.....	24
Remote Mount.....	24
MAINTENANCE & REPAIR.....	25
APPENDIX	26
Sensor Type Selection Links	26
Sensor Terminal Function (Rev.B).....	26
Operating Functions in the menu in a Hazardous Area	27

CERTIFICATION STANDARDS

IEC 60079-0:2011 Ed6, IEC 60079-1:2014 Ed7, IEC 60079-31:2013 Ed2, EN 60079-0:2012, EN 60079-1:2014, EN 60079-31:2009

Conditions of Acceptability

- (1) *(cCSAus only)* The FlowPod is Externally Powered by a Class 2, min. 12-30Vdc, 0.09A, 5W max. CSA or other NRTL certified main supply and must be an approved type acceptable to the authorities in the country where the equipment is sold.
- (2) The FlowPod shall be installed and used within the ambient temperature range that is marked on the product, however, when the products are being stored, the lower temperature remains the same, but the maximum temperature may be raised to 80°C.
- (3) Equipment has only been tested for electrical safety. No evaluation of functional safety and performance characteristics has been conducted

Certificates

Sira 15ATEX1190X
 IECEX SIR 15.0066X
 CSA Certificate 15.70006281



1 **EU-TYPE EXAMINATION CERTIFICATE**

2 Equipment intended for use in Potentially Explosive Atmospheres Directive 2014/34/EU

3 Certificate Number: **Sira 15ATEX1190X** Issue: **2**

4 Equipment: **FlowPod**

5 Applicant: **Litre Meter Limited**

6 Address: Hart Hill Barn
Granborough Rd
North Marston
Buckinghamshire
MK18 3RZ
United Kingdom

7 This equipment and any acceptable variation thereto is specified in the schedule to this certificate and the documents therein referred to.

8 Sira Certification Service, notified body number 0518 in accordance with Articles 17 and 21 of Directive 2014/34/EU of the European Parliament and of the Council, dated 26 February 2014, certifies that this equipment has been found to comply with the Essential Health and Safety Requirements relating to the design and construction of equipment intended for use in potentially explosive atmospheres given in Annex II to the Directive.

The examination and test results are recorded in the confidential reports listed in Section 14.2.

9 Compliance with the Essential Health and Safety Requirements, with the exception of those listed in the schedule to this certificate, has been assured by compliance with the following documents:

EN 60079-0:2012/A11:2013 EN 60079-1:2014 EN 60079-31:2014

The above list of documents may detail standards that do not appear on the UKAS Scope of Accreditation, but have been added through Sira's flexible scope of accreditation, which is available on request.

10 If the sign 'X' is placed after the certificate number, it indicates that the equipment is subject to Specific Conditions of Use identified in the schedule to this certificate.

11 This EU-Type Examination Certificate relates only to the design and construction of the specified equipment. If applicable, further requirements of this Directive apply to the manufacture and supply of this equipment.

12 The marking of the equipment shall include the following:

 II 2 G D
Ex db IIC T5
Ex tb IIIC 80 °C
Refer to Description of Equipment for ambient temperature.

Project Number 70182181

This certificate and its schedules may only be reproduced in its entirety and without change.

Form 9400 Issue 4

Page 1 of 4

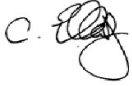
C Ellaby
Deputy Certification Manager

Sira Certification Service

Unit 6 Hawarden Industrial Park,
Hawarden, CH5 3US, United Kingdom

Tel: +44 (0) 1244 670900
Fax: +44 (0) 1244 681330
Email: ukinfo@csagroup.org
Web: www.csagroupuk.org



SCHEDULE

EU-TYPE EXAMINATION CERTIFICATE

**Sira 15ATEX1190X
Issue 2**

13 DESCRIPTION OF EQUIPMENT

Direct Mount FlowPod

The FlowPod is used to measure the flow of process liquids with the measurement electronics and display housed in the stainless steel enclosure body. The sensor assembly is contained in the meter cap which is connected to the enclosure body with a stainless steel union. The enclosure body is an Ex d certified IME Type 8080SM flameproof enclosure with certification Sira 07ATEX1331U which has two cable entries for the connection of suitably certified cable entry devices, adaptors or blank plugs. The FlowPod meets the ingress protection requirements of IP66/IP68 (2m) and is rated, 12 – 30 V, 2 W maximum.

Direct Mount FlowPod as option with KEM sensor

For use in gas atmospheres, the sensor assembly and the stainless steel union can be replaced by an Ex d certified "FLOWPOD SENSOR ADAPTOR" by KEM Küppers Elektromechanik GmbH with certification Sira 16ATEX1261U.

Remote Mounting Option

The FlowPod enclosure body can be mounted remotely from the sensor with a junction box fitted in place of the FlowPod enclosure body on the meter cap. The stainless steel junction box is an Ex d certified IME Type 1080SM flameproof enclosure with certification Sira 09ATEX1023U.

Remote Mounting Option with KEM sensor

The remote mounting option is also possible with the "FLOWPOD SENSOR ADAPTOR" by KEM Küppers Elektromechanik GmbH.

Stand-alone FlowPod Option

The FlowPod enclosure body can also be mounted remotely from the sensor with a cable gland fitted in place of the sensor.

Ambient Temperature

Ambient temperature range for equipment marked with Ex tb:	Ta = -20 °C to +75 °C
Extended ambient temperature range for stainless steel FlowPod and junction box marked with Ex db:	Ta = -40 °C to +75 °C
Ambient temperature range for aluminium FlowPod marked with Ex db (not subjected to a routine overpressure test):	Ta = -20 °C to +75 °C
Extended ambient temperature range for aluminium Flowpod marked with Ex db (subjected to a routine overpressure test):	Ta = -40 °C to +75 °C

Variation 1 - This variation introduced the following changes:

- i. The introduction of alternative stainless steel grades for the meter cap.
- ii. The addition of a lock nut to the sensor assembly.
- iii. The recognition of minor, editorial amendments to Drawing K0013-CERT-003-F.

Variation 2 - This variation introduced the following changes:

- i. Change the lower ambient temperature limit from -20 °C to -40 °C for the stainless steel FlowPod, the junction box and the aluminium FlowPod, subjected to a routine overpressure test, marked with Ex db.

This certificate and its schedules may only be reproduced in its entirety and without change.

Form 9400 Issue 4

Page 2 of 4

Sira Certification Service

Unit 6 Hawarden Industrial Park,
Hawarden, CH5 3US, United Kingdom

Tel: +44 (0) 1244 670900
Fax: +44 (0) 1244 681330
Email: ukinfo@csagroup.org
Web: www.csagroupuk.org



SCHEDULE

EU-TYPE EXAMINATION CERTIFICATE

Sira 15ATEX1190X Issue 2

- ii. Optional combination of the component certified 'KEM Sensor' certified under Sira 16ATEX1261U for the Ex db versions of the equipment, with the subsequent addition of the suffix 'X' to the certificate number.
iii. Introduce an alternate pcb design for the FlowPod and the junction box.
iv. The introduction of the direct mount option and junction box made of aluminium as alternative to the stainless steel options.
v. Introduce a stand-alone Flowpod option.

14 DESCRIPTIVE DOCUMENTS

14.1 Drawings

Refer to Certificate Annexe.

14.2 Associated Sira Reports and Certificate History

Table with 4 columns: Issue, Date, Report number, Comment. It lists three issues: Issue 0 (24 July 2015), Issue 1 (23 September 2015), and Issue 2 (18 February 2019) which details changes to the certificate in accordance with Directive 2014/34/EU.

15 SPECIFIC CONDITIONS OF USE (denoted by X after the certificate number)

- 15.1 The flamepaths of the KEM "FLOWPOD SENSOR ADAPTOR", certified under Sira 16ATEX1261U, shall not be repaired.
15.2 CAUTION - USE FASTENERS WITH YIELD STRESS ≥ 450 MPa for models with KEM "FLOWPOD SENSOR ADAPTOR". - This condition shall be considered for the combinations of the FlowPod or junction box with the Flowpod Sensor Adaptor, certified under Sira 16ATEX1261U.
15.3 For the Stand-alone FlowPod Option the end-user shall use suitably certified Ex d cable glands, suitable for the operating temperature range of -40 °C to +85 °C to which they may be subjected in service.

16 ESSENTIAL HEALTH AND SAFETY REQUIREMENTS OF ANNEX II (EHSRs)

The relevant EHSRs that are not addressed by the standards listed in this certificate have been identified and individually assessed in the reports listed in Section 14.2.

This certificate and its schedules may only be reproduced in its entirety and without change.

Form 9400 Issue 4

Sira Certification Service

Unit 6 Hawarden Industrial Park, Hawarden, CH5 3US, United Kingdom

Tel: +44 (0) 1244 670900
Fax: +44 (0) 1244 681330
Email: ukinfo@csagroup.org
Web: www.csagroupuk.org



SCHEDULE

EU-TYPE EXAMINATION CERTIFICATE

**Sira 15ATEX1190X
Issue 2**

17 CONDITIONS OF MANUFACTURE

- 17.1 The use of this certificate is subject to the Regulations Applicable to Holders of Sira Certificates.
- 17.2 Holders of EU-Type Examination Certificates are required to comply with the conformity to type requirements defined in Article 13 of Directive 2014/34/EU.
- 17.3 The equipment covered by this certificate incorporates previously certified devices; it is therefore the responsibility of the manufacturer to continually monitor the status of the certification associated with these devices, and the manufacturer shall inform Sira of any modifications of the devices that may impinge upon the explosion safety design of the equipment.
- 17.4 The manufacturer shall conduct a routine overpressure test for the FlowPod enclosure manufactured from aluminum together with the sensor cap at a minimum of 32.1 bar according to clause 16 of EN 60079-1, if marked with a minimum ambient temperature of -40 °C.

This certificate and its schedules may only be reproduced in its entirety and without change.

Form 9400 Issue 4

Page 4 of 4

Sira Certification Service

Unit 6 Hawarden Industrial Park,
Hawarden, CH5 3US, United Kingdom

Tel: +44 (0) 1244 670900
Fax: +44 (0) 1244 681330
Email: ukinfo@csagroup.org
Web: www.csagroupuk.org

Certificate Annexe

Certificate Number: Sira 15ATEX1190X

Equipment: FlowPod

Applicant: Litre Meter Limited



Issue 0

Drawing	Sheets	Rev.	Date (Sira Stamp)	Title
K0013-CERT-001	1 of 1	F	8 Jul 15	FlowPod General Arrangement
K0013-CERT-002	1 of 1	C	8 Jul 15	FlowPod Arrangement
K0013-CERT-003	1 of 1	E	8 Jul 15	FlowPod Union Arrangement
K0013-CERT-004	1 of 1	B	8 Jul 15	FlowPod Arrangement
K0013-CERT-005	1 of 1	C	8 Jul 15	Junction Box Mount
K0013-CERT-006	1 of 1	A	8 Jul 15	Junction Box Mount

Issue 1

Drawing	Sheets	Rev.	Date (Sira stamp)	Description
K0013-CERT-003-F	1 of 1	F	26 Aug 15	FlowPod Union Arrangement

Issue 2

Drawing	Sheets	Rev.	Date (Sira stamp)	Title
K0013-CERT-001	1 of 1	G	23 Jan 19	FlowPod General Arrangement
K0013-CERT-002	1 of 1	D	23 Jan 19	FlowPod Arrangement
K0013-CERT-005	1 of 1	D	23 Jan 19	Junction Box Mount
K0013-CERT-009	1 of 1	A	23 Jan 19	KEM Junction Box Mount
K0013-CERT-010	1 of 1	A	23 Jan 19	KEM Non EXi FlowPod Arrangement
K0013-CERT-011	1 of 1	A	23 Jan 19	FlowPod Arrangement
K0013-CERT-012	1 of 1	A	23 Jan 19	FlowPod Arrangement
K0013-CERT-015	1 of 1	A	23 Jan 19	PCB Junction Box Mount
K0013-MA-016	1 of 1	A	23 Jan 19	KEM PCB Junction Box
K0013-CERT-017	1 of 1	A	23 Jan 19	KEM EXi FlowPod Arrangement
K0013-CERT-018	1 of 1	A	23 Jan 19	KEM Int Non EXi FlowPod Arrangement
K0013-CERT-019	1 of 1	A	23 Jan 19	Junction Box Mount
K0013-CERT-020	1 to 3	A	23 Jan 19	KEM Sensor Thread Arrangement
K0013-CERT-021	1 of 1	B	23 Jan 19	KEM FlowPod And Junction Box Label
K0013-CERT-022	1 of 1	A	23 Jan 19	FlowPod Stand Alone

This certificate and its schedules may only be reproduced in its entirety and without change.

Form 9400 Issue 4

Page 1 of 1

Sira Certification Service

Unit 6 Hawarden Industrial Park,
Hawarden, CH5 3US, United Kingdom

Tel: +44 (0) 1244 670900
Fax: +44 (0) 1244 681330
Email: ukinfo@csagroup.org
Web: www.csagroupuk.org



IECEX Certificate of Conformity

INTERNATIONAL ELECTROTECHNICAL COMMISSION IEC Certification Scheme for Explosive Atmospheres

for rules and details of the IECEx Scheme visit www.iecex.com

Certificate No.: IECEx SIR 15.0066X

Issue No: 2

Certificate history:

Status: **Current**

Issue No. 2 (2019-02-18)

Issue No. 1 (2015-09-23)

Date of Issue: **2019-02-18**

Page 1 of 4

Issue No. 0 (2015-07-24)

Applicant: **Litre Meter Limited**
Hart Hill Barn
Granborough Rd
North Marston
Buckinghamshire
MK18 3RZ
United Kingdom

Equipment: **FlowPod**

Optional accessory:

Type of Protection: **Flameproof and Dust Protection by Enclosure**

Marking: Ex db IIC T5

Ex tb IIIC 80°C

Refer to Annexe for ambient temperature

Approved for issue on behalf of the IECEx
Certification Body:

C Ellaby

Position:

Deputy Certification Manager

Signature:
(for printed version)

2019-02-18

Date:

1. This certificate and schedule may only be reproduced in full.
2. This certificate is not transferable and remains the property of the issuing body.
3. The Status and authenticity of this certificate may be verified by visiting the [Official IECEx Website](http://www.iecex.com).

Certificate issued by:

SIRA Certification Service
CSA Group
Unit 6, Hawarden Industrial Park
Hawarden, Deeside, CH5 3US
United Kingdom





IECEX Certificate of Conformity

Certificate No: IECEX SIR 15.0066X Issue No: 2
Date of Issue: 2019-02-18 Page 2 of 4
Manufacturer: **Lite Meter Limited**
Hart Hill Barn
Granborough Rd
North Marston
Buckinghamshire
MK18 3RZ
United Kingdom

Additional Manufacturing location(s):

This certificate is issued as verification that a sample(s), representative of production, was assessed and tested and found to comply with the IEC Standard list below and that the manufacturer's quality system, relating to the Ex products covered by this certificate, was assessed and found to comply with the IECEx Quality system requirements. This certificate is granted subject to the conditions as set out in IECEx Scheme Rules, IECEx 02 and Operational Documents as amended.

STANDARDS:

The apparatus and any acceptable variations to it specified in the schedule of this certificate and the identified documents, was found to comply with the following standards:

IEC 60079-0 : 2011 Edition:6.0	Explosive atmospheres - Part 0: General requirements
IEC 60079-1 : 2014-06 Edition:7.0	Explosive atmospheres - Part 1: Equipment protection by flameproof enclosures "d"
IEC 60079-31 : 2013 Edition:2	Explosive atmospheres - Part 31: Equipment dust ignition protection by enclosure "t"

This Certificate does not indicate compliance with electrical safety and performance requirements other than those expressly included in the Standards listed above.

TEST & ASSESSMENT REPORTS:

A sample(s) of the equipment listed has successfully met the examination and test requirements as recorded in

Test Report:

GB/SIR/ExTR15.0203/00 GB/SIR/ExTR15.0245/00 GB/SIR/ExTR19.0031/00

Quality Assessment Report:

GB/SIR/QAR15.0004/03



IECEX Certificate of Conformity

Certificate No: IECEX SIR 15.0066X

Issue No: 2

Date of Issue: 2019-02-18

Page 3 of 4

Schedule

EQUIPMENT:

Equipment and systems covered by this certificate are as follows:

Direct Mount FlowPod

The FlowPod is used to measure the flow of process liquids with the measurement electronics and display housed in the stainless steel enclosure body. The sensor assembly is contained in the meter cap which is connected to the enclosure body with a stainless steel union. The enclosure body is an Ex d certified IME Type 8080SM flameproof enclosure with certification IECEX SIR 07.0111U which has two cable entries for the connection of suitably certified cable entry devices, adaptors or blank plugs. The FlowPod meets the ingress protection requirements of IP66/IP68 (2m) and is rated, 12 – 30 V, 2 W maximum.

Refer to Annexe for additional EQUIPMENT information and CONDITIONS OF MANUFACTURE.

SPECIFIC CONDITIONS OF USE: YES as shown below:

1. The flamepaths of the KEM "FLOWPOD SENSOR ADAPTOR", certified under IECEX SIR 16.0089U, shall not be repaired.
2. CAUTION – USE FASTENERS WITH YIELD STRESS ≥ 450 MPa for models with KEM "FLOWPOD SENSOR ADAPTOR". - This condition shall be considered for the combinations of the FlowPod or junction box with the Flowpod Sensor Adaptor, certified under IECEX SIR 16.0089U.
3. For the Stand-alone FlowPod Option the end-user shall use suitably certified Ex d cable glands, suitable for the operating temperature range of -40 °C to $+85$ °C to which they may be subjected in service.



IECEX Certificate of Conformity

Certificate No: IECEx SIR 15.0066X

Issue No: 2

Date of Issue: 2019-02-18

Page 4 of 4

DETAILS OF CERTIFICATE CHANGES (for issues 1 and above):

Issue 1 - this issue introduced the following changes:

1. The introduction of alternative stainless steel grades for the meter cap.
2. The addition of a lock nut to the sensor assembly.
3. The recognition of minor, editorial amendments to Drawing K0013-CERT-003-F.

Issue 2 - this issue introduced the following changes:

1. Change the lower ambient temperature limit from -20 °C to -40 °C for the stainless steel FlowPod, the junction box and the aluminium FlowPod, subjected to a routine overpressure test, marked with Ex db.
2. Optional combination of the component certified 'KEM Sensor' certified under IECEx SIR 16.0089U for the Ex db versions of the equipment, with the subsequent addition of the suffix 'X' to the certificate number.
3. Introduce an alternate pcb design for the FlowPod and the junction box.
4. The introduction of the direct mount option and junction box made of aluminium as alternative to the stainless steel options.
5. Introduce a stand-alone Flowpod option.

Annex:

[IECEX SIR 15.0066X Annexe_Issue 2.pdf](#)

Annexe to: IECEx SIR 15.0066X Issue 2
Applicant: Litre Meter Limited
Apparatus: FlowPod



EQUIPMENT (continued)

The full equipment description is shown as follows:

Direct Mount FlowPod

The FlowPod is used to measure the flow of process liquids with the measurement electronics and display housed in the stainless steel enclosure body. The sensor assembly is contained in the meter cap which is connected to the enclosure body with a stainless steel union. The enclosure body is an Ex d certified IME Type 8080SM flameproof enclosure with certification IECEx SIR 07.0111U which has two cable entries for the connection of suitably certified cable entry devices, adaptors or blank plugs. The FlowPod meets the ingress protection requirements of IP66/IP68 (2m) and is rated, 12 – 30 V, 2 W maximum.

Direct Mount FlowPod as option with KEM sensor

For use in gas atmospheres, the sensor assembly and the stainless steel union can be replaced by an Ex d certified "FLOWPOD SENSOR ADAPTOR" by KEM Küppers Elektromechanik GmbH with certification IECEx SIR 16.0089U.

Remote Mounting Option

The FlowPod enclosure body can be mounted remotely from the sensor with a junction box fitted in place of the FlowPod enclosure body on the meter cap. The stainless steel junction box is an Ex d certified IME Type 1080SM flameproof enclosure with certification IECEx SIR 09.0006U.

Remote Mounting Option with KEM sensor

The remote mounting option is also possible with the "FLOWPOD SENSOR ADAPTOR" by KEM Küppers Elektromechanik GmbH.

Stand-alone FlowPod Option

The FlowPod enclosure body can also be mounted remotely from the sensor with a cable gland fitted in place of the sensor.

Ambient Temperature

Ambient temperature range for equipment marked with Ex tb:	Ta = -20 °C to +75 °C
Extended ambient temperature range for stainless steel FlowPod and junction box marked with Ex db:	Ta = -40 °C to +75 °C
Ambient temperature range for aluminium FlowPod marked with Ex db (not subjected to an routine overpressure test):	Ta = -20 °C to +75 °C
Extended ambient temperature range for aluminium Flowpod marked with Ex db (subjected to an routine overpressure test):	Ta = -40 °C to +75 °C

Conditions of Manufacture

The Manufacturer shall comply with the following:

1. The equipment covered by this certificate incorporates previously certified devices; it is therefore the responsibility of the manufacturer to continually monitor the status of the certification associated with these devices, and the manufacturer shall inform Sira of any modifications of the devices that may impinge upon the explosion safety design of the equipment.
2. The manufacturer shall conduct a routine overpressure test for the FlowPod enclosure manufactured from aluminum together with the sensor cap at a minimum of 32.1 bar according to clause 16 of IEC 60079-1, if marked with a minimum ambient temperature of -40 °C.

Date: 18 February 2019

Page 1 of 1

Form 9530 Issue 1

Sira Certification Service

Unit 6 Hawarden Industrial Park,
Hawarden, CH5 3US, United Kingdom

Tel: +44 (0) 1244 670900
Fax: +44 (0) 1244 681330
Email: ukinfo@csagroup.org
Web: www.csagroupuk.org



Certificate of Compliance

Certificate: 70006281

Master Contract: 261530

Project: 70006281

Date Issued: August 24, 2015

Issued to: **Litre Meter Limited**
Hart Hill Barn
Granborough Road
North Marston
Buckinghamshire
MK18 3RZ, UK

Attention: Chris Iacofano

The products listed below are eligible to bear the CSA Mark shown with adjacent indicators 'C' and 'US' for Canada and US or with adjacent indicator 'US' for US only or without either indicator for Canada only



Issued by: *B. Spencer*
B. Spencer

PRODUCTS

CLASS 2258 02 - PROCESS CONTROL EQUIPMENT - For Hazardous Locations

Class I, Div 1, Groups B, C, D;
Class II, Div 1, Groups E, F, G; Class III, Div 1
Ex d IIC T5 Gb
Ex tb IIIC T80°C Db
 $T_{amb} = -20^{\circ}\text{C}$ to $+75^{\circ}\text{C}$
IP66/IP68 (2m)

CLASS 2258 82 - PROCESS CONTROL EQUIPMENT - For Hazardous Locations - Certified to US Standards

Class I, Div 1, Groups B, C, D;
Class II, Div 1, Groups E, F, G; Class III, Div 1
Class I, Zone 1, AEx d IIC T5 Gb
Zone 21 AEx t IIIC T5 Db
 $T_{amb} = -20^{\circ}\text{C}$ to $+75^{\circ}\text{C}$
IP66/IP68 (2m)



Certificate: 70006281
Project: 70006281

Master Contract: 261530
Date Issued: August 24, 2015

Models

FlowPod, standard mounting
FlowPod, remote mounting

Electrical Rating: 12 - 30 VDC; 2 W

Notes:

1. The above models are cord connected, Equipment Class 1, Pollution Degree 2 and Overvoltage Category II.
2. Mode of operation: Continuous
3. Environmental Conditions: 2000m max, Maximum ambient temperature for all models: -20 to +75 ° C
4. Weight of Equipment: FlowPod without cap 1.6kg.

APPLICABLE REQUIREMENTS

- | | |
|-------------------------------|--|
| C22.2 No. 25-1966 | - Enclosures for Use in Class II, Groups E, F and G Hazardous Locations |
| C22.2 No. 30-M1986 | - Explosion-Proof Enclosures for Use in Class I Hazardous Locations |
| CAN/CSA-C22.2 No. 60079-0:11 | - Electrical apparatus for explosive gas atmospheres - Part 0: General requirements |
| CAN/CSA-C22.2 No. 60079-1:11 | - Electrical apparatus for explosive gas atmospheres - Part 1: Flameproof enclosures "d" |
| CAN/CSA-C22.2 No. 60079-31:12 | - Electrical apparatus for explosive gas atmospheres - Part 31: Equipment dust ignition protection by enclosure "t" |
| CAN/CSA-C22.2 No. 60529:05 | - Degrees of protection provided by enclosures (IP Code) |
| FM Class 3600:2011 | - Electrical equipment for use in hazardous (classified) locations, general requirements |
| FM Class 3615:2006 | - Explosion proof equipment, general requirements |
| FM Class 3636:2011 | - Dust-ignitionproof electrical equipment, general requirements |
| ANSI/ISA 60079-0:2013 | - Explosive atmospheres - Part 0: Equipment - General requirements |
| ANSI/ISA 60079-1:2013 | - Explosive atmospheres - Part 1: Equipment protection by flameproof enclosures "d" |
| ANSI/ISA 60079-31:2013 | - Explosive atmospheres - Part 31: Equipment protection by enclosure "t" |
| ANSI/IEC 60529:2004 | - Degrees of Protection Provided by Enclosures (IP Code) |
| CAN/CSA C22.2 No. 61010-1-12 | - Safety Requirements for Electrical Equipment for Measurement, Control, and Laboratory Use - Part 1: General Requirements - Third Edition |
| ANSI/ISA-61010-1 3rd Edition | - Safety Requirements for Electrical Equipment for Measurement, Control, and Laboratory Use - Part 1: General Requirements - Third Edition |



Certificate: 70006281
Project: 70006281

Master Contract: 261530
Date Issued: August 24, 2015

MARKINGS

The manufacturer is required to apply the following markings:

- Products shall be marked with the markings specified by the particular product standard.
- Products certified for Canada shall have all Caution and Warning markings in both English and French.

Additional bilingual markings not covered by the product standard(s) may be required by the Authorities Having Jurisdiction. It is the responsibility of the manufacturer to provide and apply these additional markings, where applicable, in accordance with the requirements of those authorities.

The products listed are eligible to bear the CSA Mark shown with adjacent indicators 'C' and 'US' for Canada and US (indicating that products have been manufactured to the requirements of both Canadian and U.S. Standards) or with adjacent indicator 'US' for US only or without either indicator for Canada only.

The following marking details appear:

- CSA Mark with adjacent indicators 'C' and 'US' for Canada and US.
- Company Name.
- Model designation, as specified in the PRODUCTS section.
- Electrical rating, as specified in the PRODUCTS section.
- Maximum ambient temperature rating, as specified in the PRODUCTS section.
- Date code / Serial number traceable to month and year of manufacture.
- Hazardous Location designation, as specified in the PRODUCTS section.
- Temperature code, as specified in the PRODUCTS section.
- Ingress Protection Rating "IP 66/IP68 (2m)".
- The warning: "OPEN CIRCUIT BEFORE REMOVING COVER."
- The warning: "SEE INSTALLATION INSTRUCTION DOCUMENT"
- Statement: "A SEAL SHALL BE INSTALLED WITHIN 50 MM OF THE ENCLOSURE".
- CSA Certificate Number CSA 15-70006281

The marking label is 0.5 mm thick stainless steel and secured to the equipment with rivets

CONDITIONS OF ACCEPTABILITY

- (1) The Flow Pod is externally powered by a NEC Class 2, min. 12-30Vdc, 0.09 A, 5W max min. CSA or other NRTL certified main supply and must be an approved type acceptable to the authorities in the country where the equipment is sold.
- (2) The Flow Pod shall be installed and used within the ambient temperature range that is marked on the product, however, when the products are being stored, the lower temperature remains the same, but the maximum temperature may be raised to 75°C.
- (3) Equipment has only been tested for electrical safety. No evaluation of functional safety and performance characteristics has been conducted.

ENCLOSURE LABELS

LM CIM-series Sensor (VFF) & Stand-alone Display

FlowPod Enclosure

MODEL: FLOWPOD SERIAL No.: XXXXXXXX YEAR OF MANU.: XXXX
STOCK CODE: FLOWPOD-X-XX-XX-XXXX CONNECTIONS: XXXXXX
VOLTAGE: 12V TO 30V / 2W Max. AMBIENT RANGE: -20°C TO +75°C
IP66 IP68 (2m) ATEX/IECEX Ex d RANGE: -40°C TO +75°C

Class I Div1, Groups B,C,D - Class II Div1, Groups E,F,G - Class III Div1
IECEX - Ex tb IIIC 80 °C - Ex db IIC T5 - IECEX SIR 15.0066
ATEX - Ex tb IIIC 80 °C - Ex db IIC T5 - SIRA 15 ATEX1190



CSA CERTIFICATE 15.70006281

CSA CAN CERTIFICATION ONLY Ex d IIC T5 Gb - Ex tb IIIC T80°C Db
CSA - CLASS I ZONE I AEx d IIC T5 Gb - Zone 21 AEx † IIIC T5 Db

OPEN CIRCUIT BEFORE REMOVING COVER
OUVRIRE LE CIRCUIT AVANT D'ENLEVER LE COUVERCLE
A SEAL SHALL BE INSTALLED WITHIN 50mm OF THE ENCLOSURE
UN SCÉLLEMENT DOIT ÊTRE INSTALLÉ MOINS DE 50mm DU BOÎTIER
SEE INSTALLATION INSTRUCTION DOCUMENT
VOIR LES INSTRUCTIONS D'INSTALLATION LE DOCUMENT
LITRE METER, NORTH MARSTON, BUCKS, MK18 3RZ, UK

 0518

 II 2 G D

  Specialist flow measurement engineering

Remote Enclosure (Remote Junction Box)

MODEL: FLOWPOD SERIAL No.: XXXXXXXX YEAR OF MANU.: XXXX CONNECTIONS: XXXXXX
AMBIENT RANGE: -20°C TO +75°C STOCK CODE: FLOWPOD-X-XX-XX-XXXX
ATEX/IECEX Ex d RANGE: -40°C TO +75°C IP66 IP68 (2m) VOLTAGE: 12V TO 30V / 2W Max.

Class I Div1, Groups B,C,D - Class II Div1, Groups E,F,G - Class III Div1
IECEX - Ex tb IIIC 80 °C - Ex db IIC T5 - IECEX SIR 15.0066
ATEX - Ex tb IIIC 80 °C - Ex db IIC T5 - SIRA 15 ATEX1190



CSA CERTIFICATE 15.70006281

CSA CAN CERTIFICATION ONLY Ex d IIC T5 Gb - Ex tb IIIC T5 Db
CSA - CLASS I ZONE I AEx d IIC T5 Gb - Zone 21 AEx † IIIC T5 Db

OPEN CIRCUIT BEFORE REMOVING COVER
OUVRIRE LE CIRCUIT AVANT D'ENLEVER LE COUVERCLE
A SEAL SHALL BE INSTALLED WITHIN 50mm OF THE ENCLOSURE
UN SCÉLLEMENT DOIT ÊTRE INSTALLÉ MOINS DE 50mm DU BOÎTIER
SEE INSTALLATION INSTRUCTION DOCUMENT
VOIR LES INSTRUCTIONS D'INSTALLATION LE DOCUMENT
LITRE METER, NORTH MARSTON, BUCKS, MK18 3RZ, UK

 0518

 II 2 G D

  Specialist flow measurement engineering

KEM SV-series Sensor

FlowPod Enclosure:





MODEL: FLOWPOD SERIAL No.: XXXXXXX YEAR OF MANU.: XXXX
STOCK CODE: FLOWPOD-X-XX-XX-XXXX CONNECTIONS: XXXXXX
VOLTAGE: 12V TO 30V / 2W Max. AMBIENT RANGE: -40°C TO +75°C
IP66 IP68 (2m) ATEX/IECEX EXd RANGE: -40°C TO +75°C

Class I Div1, Groups B,C,D - Class II Div1, Groups E,F,G - Class III Div1
IECEX - Ex db IIC T5 - IECEX SIR 15.0066
ATEX - Ex db IIC T5 - SIRA 15 ATEX1190

CSA CERTIFICATE 15.70006281



CSA CAN CERTIFICATION ONLY Ex d IIC T5 Gb - Ex tb IIIC T80°C Db
CSA - CLASS I ZONE I AEx d IIC T5 Gb - Zone 21 AEx † IIIC T5 Db

OPEN CIRCUIT BEFORE REMOVING COVER
OUVRIR LE CIRCUIT AVANT D'ENLEVER LE COUVERCLE
A SEAL SHALL BE INSTALLED WITHIN 50mm OF THE ENCLOSURE
UN SCÉLÈMENT DOIT ÊTRE INSTALLÉ MOINS DE 50mm DU BOITIER
SEE INSTALLATION INSTRUCTION DOCUMENT
VOIR LES INSTRUCTIONS D'INSTALLATION LE DOCUMENT
LITRE METER, NORTH MARSTON, BUCKS, MK18 3RZ, UK

 0518
 II 2 G
  Specialist flow measurement engineering

Remote Junction Box

MODEL: FLOWPOD SERIAL No.: XXXXXXX YEAR OF MANU.: XXXX CONNECTIONS: XXXXXX
AMBIENT RANGE: -40°C TO +75°C STOCK CODE: FLOWPOD-X-XX-XX-XXXX
ATEX/IECEX EXd RANGE: -40°C TO +75°C IP66 IP68 (2m) VOLTAGE: 12V TO 30V / 2W Max.

 0518
Class I Div1, Groups B,C,D - Class II Div1, Groups E,F,G - Class III Div1
IECEX - Ex db IIC T5 - IECEX SIR 15.0066
ATEX - Ex db IIC T5 - SIRA 15 ATEX1190
 II 2 G

CSA CERTIFICATE 15.70006281
CSA CAN CERTIFICATION ONLY Ex d IIC T5 Gb - Ex tb IIIC T5 Db
CSA - CLASS I ZONE I AEx d IIC T5 Gb - Zone 21 AEx † IIIC T5 Db

OPEN CIRCUIT BEFORE REMOVING COVER
OUVRIR LE CIRCUIT AVANT D'ENLEVER LE COUVERCLE
A SEAL SHALL BE INSTALLED WITHIN 50mm OF THE ENCLOSURE
UN SCÉLÈMENT DOIT ÊTRE INSTALLÉ MOINS DE 50mm DU BOITIER
SEE INSTALLATION INSTRUCTION DOCUMENT
VOIR LES INSTRUCTIONS D'INSTALLATION LE DOCUMENT
LITRE METER, NORTH MARSTON, BUCKS, MK18 3RZ, UK

 Specialist flow measurement engineering

GENERAL INSTRUCTIONS

The FlowPod display is housed in either a Stainless Steel or Epoxy-Painted Aluminium enclosure that can be supplied mounted directly on to the flowmeter, with integral connections; or remotely via suitable cable and glanded cable entries; or as a separate display with empty cable entries for installation by the customer.

Cables and Glands

All cables, glands and cable in conduit should be suitable for the following conditions:

	ATEX/IEC-Ex	cCSAus
Operating Temperature Range	-40°C to +85°C	-40°C to +85°C
Ingress Protection	IP66/IP68 (2m)	NEMA 4X
Certification	Ex db Ex tb	Ex db Ex tb
Thread Size	¾" NPT or M20	¾" NPT or M20 (M20 not Canada)

All cable entries will be either ¾" NPT or M20 thread sizes. These can be identified by the relevant code in the instrument part code on the instrument or the remote junction box:

	Code	Field Entry	Sensor Entry
FlowPod	E*1	2x ¾" NPT	1x ¾" NPT
	E*2	2x M20	1x ¾" NPT
	E*3	2x M20	1x M20
Junction Box	J*1	1x ¾" NPT	1x ¾" NPT
	J*2	1x M20	1x ¾" NPT
Material (*)	Blank = 316L Stainless Steel	S = 316L Stainless Steel	A = Epoxy Painted Aluminium

A seal shall be installed within 50mm of the enclosure, if not incorporated in to suitable barrier glands.

Grounding and Bonding Terminals

The Enclosure and remote Junction Box include a supplementary external grounding or bonding terminal that is identified by being either coloured green and/or by being marked "≡".

The internal grounding terminal shall be used for the equipment grounding connection and the external terminal is for a supplementary bonding connection where local codes or authorities permit or require such connection.

The Enclosure will require external bonding to the flowmeter body. Wire used for this purpose must be a minimum of 4mm² (or equivalent).

SAFETY PARAMETERS

Temperature

	Gas (Ex db)	Dust (Ex tb)	Comments
Ambient – Stainless Steel	-40°C to +75°C	-20°C to +75°C	
Ambient – Aluminium	-20°C to +75°C	-20°C to +75°C	(-40° available to special order for Gas (Ex db).
Storage Temperature Range	-40°C to +80°C	-40°C to +80°C	
Max. Surface Temp. (T5):	+100°C	+80°C	

Power

Power Supply (Loop & External Power)	Voltage range	12-30 Vdc	
	Current	90 mA max.	Max. Total current all in/out combined
	Power	2.0 W max.	Max. Total Power all in/out combined
Loop Current	Normal range	4.0 – 20.0 mA	
	Overrange	< 21mA (Overrange)	
	Fault	>21mA <= 24mA	
Sensor Excitation		3.3 / 5 / 8 / 12 / 15 / Ext.V	Rev.B = Factory select, Ext.V all others
Ext. Power mA (dependant on sensor / options.)		65mA max.	Total available current for all options.
OC1 & OC2 outputs		30Vdc max./ 50mA max.	Absolute max. for each output.

Total current/power of all inputs & outputs combined MUST not exceed 90mA/2.0W

Sensor

Signal Type	Frequency Input	
Frequency Range	0.001 Hz to 10.0 kHz	Low Pass filter limits at approx. 50 Hz
Sensor Types	Reed Switch / Open Transistor / NPN / PNP / Inductive Coil / Carrier Freq. Coil / Variable Resistor/ NAMUR / Sine Wave.	'Debounce' Low Pass filter on some inputs. In-built amplifier available for coil inputs.
Sensor Excitation Supply	3.3 / 5 / 8 / 12 / 15 / Ext.V	Rev.B = Factory selected, Ext.V all others
Internal Reference Voltage	3.3 Vdc	
Max. Signal Voltage	24 Vdc	Dependant on signal type.

Electrical Connections:

- Externally Powered 4-20mA loop, with HART communications
- External DC Power supply (version dependant)
- RS485 interface (version dependant)
- 2x Transistor outputs (external power required)
- Sensor signal(s) and internal DC Excitation Supply (version dependant)
- Control Signal input (version dependant)

All electrical connections will require external fuses or protection circuits, as required. No internal fuses are fitted. This equipment does not contain any batteries.

Miscellaneous

- Flamepaths shall not be repaired.



CAUTION – use fasteners with yield stress ≥ 450 mPa for models with KEM SV-series FlowPod sensor adaptor.

INSTALLATION

Assembly & Disassembly

The unit will typically be supplied assembled onto a flowmeter, for Direct-mount versions. Remote-mount versions may be supplied with a sensor cable, or with empty entries for customer-supplied cables/glands.

For most installations, it is advised to disconnect the sensor cabling at the meter or junction box, in preference to the instrument connections. However, where conditions require it may be beneficial to disconnect the wiring at the instrument.

The M4x10 stainless steel set screw needs to be screwed in once lid is fully screwed down/secured.

Direct-mount unit

CIFM Sensor Union

The direct-mount stem includes a union that can be split to separate the instrument from the flowmeter. This is achieved by loosening the union nut and carefully lifting the display a short distance. **NOTE: care must be exercised to avoid damage to the flame-path surfaces and also the sensor wiring.** Once separated slightly it will be possible to access the sensor connector inside the mounting stem. Undo the locknut of the connector and remove from the sensor assembly. The instrument can now be removed from the flowmeter.

Assembly is the reverse of this procedure.

KEM Sensor Adaptor - SV-series

The SV adaptor must be removed from the meter body first. This may require field wiring to be removed to allow the FlowPod/Sensor assembly to be rotated.

Loosen sensor lock-nut at meter body then unscrew sensor from meter body, by rotating complete display & sensor assembly.

Assembly is reverse of this procedure. However, do not overtighten sensor into meter body to position display alignment. If display alignment needs adjusting, loosen grub screws on side of SV-sensor adaptor to allow rotation of display to desired position. Do not rotate display >180°. Re-tighten grub screws.

Remote-mount unit

Disconnecting the sensor wiring of the Remote-mounted unit will require access to the field connections inside the main enclosure. See below for details.

Field Connections

All sensor and Field connections are made to a terminal board mounted in the base of the enclosure. Terminals are two-part and can be removed for ease of assembly.

NOTE: max. wire capacity for each terminal is 1.5mm².

Where supplied as a system with a flowmeter, or where a specific sensor type has been specified, the device will be configured for the appropriate sensor. In all other cases, please consult the supplier for details and advice BEFORE connections are made.

Field connections can be accessed by removing the front cover of the enclosure and removing the LCD module. (Note orientation of module when removing, to ensure correct re-fitting later.) The module is connected to the terminal board with a ribbon cable. If necessary, this may be disconnected from the LCD module to aid access to the terminals.



CAUTION: *the LCD module is mounted on pillars with retaining springs. Care must be taken not to lose the springs when removing the LCD module. Ensure springs are re-fitted onto pillars prior to re-fitting LCD module. When refitting the LCD module, ensure it is correctly orientated and that the mounting pillars locate in the moulded holes in the plastic bezel.*



Advise Factory of any changes made to the display – including, but not limited to, display board change, sensor change, housing change.

Terminal Board Layout Diagrams & Terminal Assignment

Terminal Board (Rev. B)

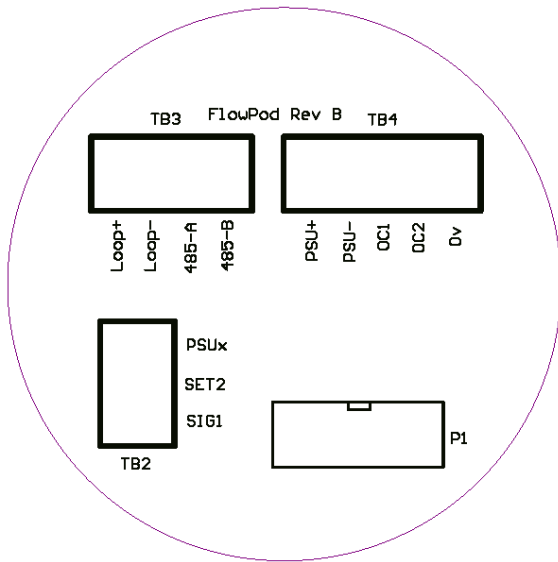

Block		Use (* = refer to appendix for details)
TB2	Sig1	Primary Sensor + (*)
	Set2	Primary Sensor - or Secondary Sensor + for Dual Reed Sensor (*)
	PSUx	Sensor Excitation + or 0V Return for Reed Sensors (*)
TB3	Loop+	4-20mA Loop Input / Supply Voltage + (loop-powered version)
	Loop-	4-20mA Loop Return / Supply Voltage - (loop-powered version)
	485-A	Optional RS485 Comms.
	485-B	Optional RS485 Comms.
TB4	PSU+	External Power + (12-24Vdc) ('4-wire' version only)
	PSU-	External Power - (0Vdc) ('4-wire' version only)
	OC1	Switch output 1
	OC2	Switch output 2
	0V	Optional 0Vdc connection for sensors

Terminal Board (Rev. C)

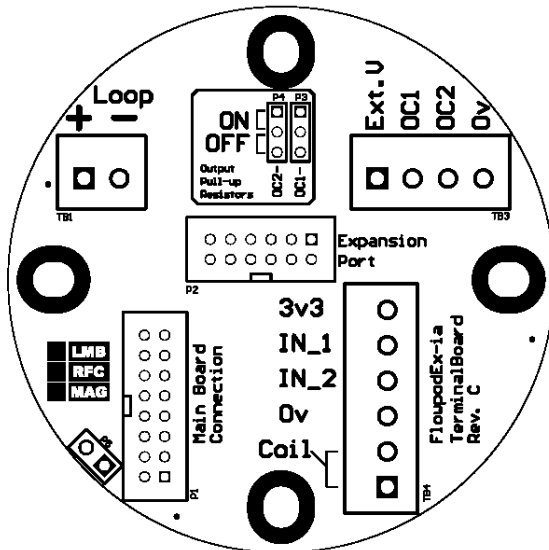

Block		Use
TB1	Loop+	4-20mA Loop Input / Supply Voltage + (loop-powered version)
	Loop-	4-20mA Loop Return / Supply Voltage - (loop-powered version)
TB3	Ext.V	External Power +V
	OC1	Switch output 1
	OC2	Switch output 2
	0V	0V common for outputs & Ext.V
TB4	3V3	3v3 Reference voltage/sensor supply
	IN_1	Pulse Input Ch.1 (NPN/PNP/Reed, etc.)
	IN_2	Pulse Input Ch.2 (NPN/PNP/Reed, etc.)
	0V	0V common for sensor inputs
	Coil	RF/Inductive (Mag) Coil sensor inputs
P2		Expansion port connector
P3		OC1 pull-up selector
P4		OC2 pull-up selector

Terminal Board (Rev. E)

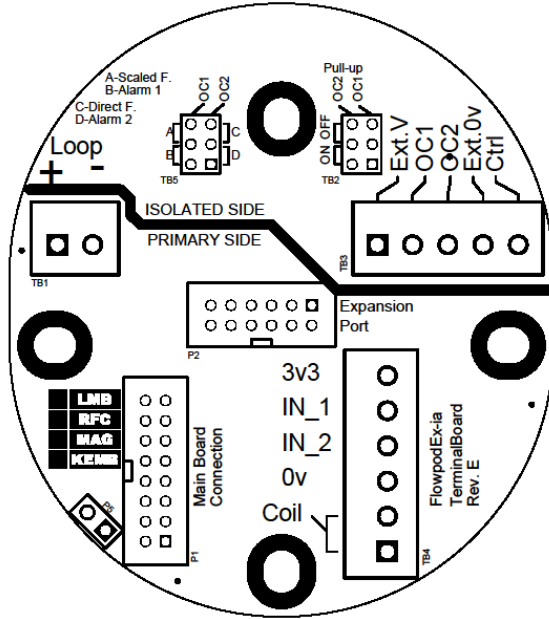

Block		Use
TB1	Loop+	4-20mA Loop Input / Supply Voltage + (loop-powered version)
	Loop-	4-20mA Loop Return / Supply Voltage - (loop-powered version)
TB3	Ext. V	External Power +V
	OC1	Switch output 1
	OC2	Switch output 2
	Ext. 0V	0V common for outputs & Ext.V
TB4	Ctrl	Control Signal Input
	3V3	3v3 Reference voltage/sensor supply
	IN_1	Pulse Input Ch.1 (NPN/PNP/Reed, etc.)
	IN_2	Pulse Input Ch.2 (NPN/PNP/Reed, etc.)
	0V	0V common for sensor inputs
	Coil	RF/Inductive (Mag) Coil sensor inputs
	Coil	RF/Inductive (Mag) Coil sensor inputs
P2		Expansion port connector
TB2		OC1/OC2 pull-up selector
TB5		OC1/OC2 function selector

Junction Box / Remote Terminal Boards (Rev. A)

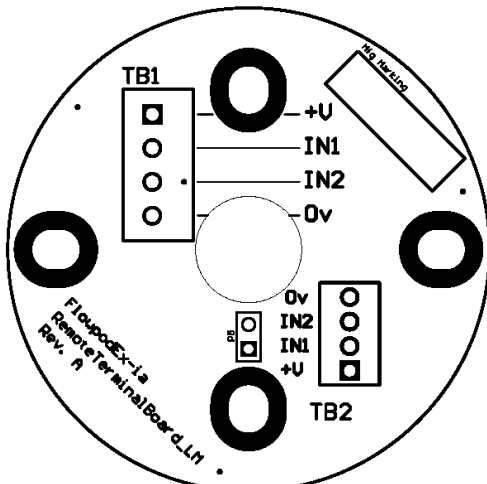

Remote terminals LM (Pulse signals) Rev.A

Block			Use
TB1	+V		Ref.V/sensor supply from Display
	IN_1		Ch.1 signal to Display
	IN_2		Ch.2 signal to Display
	0V		0V common to Display
TB2	+V		Ref.V/sensor supply to Sensor
	IN_1		Ch.1 signal from Sensor
	IN_2		Ch.2 signal from Sensor
	0V		0V common from Sensor

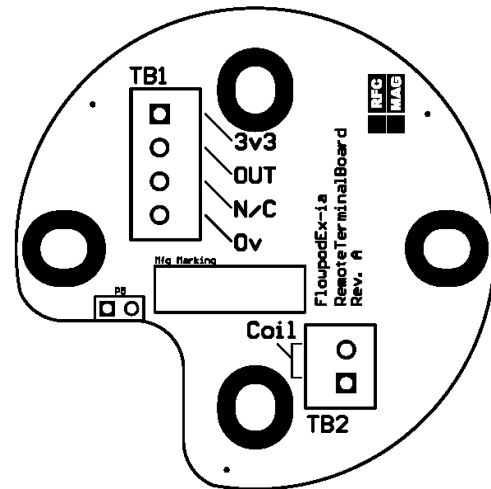

Remote terminals (RF/Mag Coils) Rev.A

Block		Use
TB1	3v3	Ref.V/sensor supply from Display
	Out	Ch.1 signal to Display
	N/C	No Connection
	0V	0V common to Display
TB2	Coil	RF/Inductive (Mag) Coil sensor inputs
	Coil	RF/Inductive (Mag) Coil sensor inputs

Sensor connections

Direct-mounted displays will include sensor wiring, which will normally be connected.

Remote mounted display will require sensor connections via cable entry.

A terminal block is provided for sensor connections. These terminals have different functions depending on the sensor type. Details of connections will be found in the Configuration and operating instructions. Typical and project-specific wiring diagrams should also be consulted.

Display Orientation

The display can be mounted in many orientations, depending on the position of the flowmeter:

Direct Mount

HORIZONTAL: Assuming the meter is installed horizontally, with the display perpendicular, the horizontal orientation of the display can be changed simply by loosening the union in the mounting stem and rotating the display to the required position. Re-tighten the union nut. (NB: SV-type union is secured by 2x hex grub screws.)



CAUTION: Care must be exercised to ensure that the head is not rotated to far so as to twist the sensor wires unnecessarily.

VERTICAL: the LCD module within the enclosure may be rotated in 90° steps:

- Remove front cover of enclosure.
- Carefully remove LCD/display module from enclosure. (**CAUTION:** ensure retaining springs on mounting pillars are not lost.)
- Rotate display in required direction and refit module onto mounting pillars, ensuring that the springs are fitted and that the pillars locate into the moulded holes in the plastic bezel.
- Refit enclosure cover.

Remote Mount

HORIZONTAL: The horizontal orientation will be determined by the mounting bracket and location.

VERTICAL: Adjustment of the Vertical orientation will be the same as for Direct-mount.

MAINTENANCE & REPAIR

There are no user-serviceable parts inside this unit. Repairs should only be undertaken at the factory or by an approved distributor.

It may be possible to replace the LCD module, however, the calibration data will need to be transferred to the new module. Refer to the factory for assistance.



Caution: *it is possible to damage the internal components if the unit is disassembled or assembled without the correct training.*

Most configuration and calibration functions can be undertaken via HART or via a PC using the LM-MC memory card programming adaptor (LMMC-USB). Some configuration settings can only be performed via a PC using HART and are not available via a Hand-Held Communicator or standard HART control system. Refer to the FlowPod Utility User Manual [LM0663] for details.

Some configuration can be achieved by using an external magnet. Please see section: Operating Functions in the menu in a Hazardous Area.

APPENDIX

Sensor Type Selection Links

Code	Sensor Type	Signal Input	Links Fitted (Rev.B only)
.LM	LM NPN Type	Pull-up	S7, S11
.LM+	LM+ NPN Type	Pull-up	S7, S11
.MAG	Mag. Coil (Inductive) *	Pull-down	S7, S11
.NMR	Namur Pulse	Namur	S7, S11
.NMR-LP	Namur Pulse	Namur + Debounce	S7, S11
.NPN	NPN Pulse	Pull-up	S7, S11
.NPN-LP	NPN Pulse	Pull-up + Debounce	S7, S11
.OT	Open Collector (NPN)	Pull-up	S7, S11
.PNP	PNP Voltage	Pull-down	S7, S11
.PNP-LP	PNP Voltage	Pull-down + Debounce	S7, S11
.RF	RF Coil (Carrier Freq.) *	Pull-down	S7, S11
.RS	Reed Switch	Pull-up + Debounce	S9, S10
.RSX	LM Field Sensor	Pull-up + Debounce	S9, S11
.SIN	Coil / Inductive	Sine Wave	S8
.VR	Variable Resistor	Pull-up + Debounce	TBC
.X	Other Sensor	Pull-up	S7, S11

* On-board RF/MAG amplifier circuit required. Use SIN for MAG if no amplifier.

Sensor Terminal Function (Rev.B)

Terminal	TB2-1	TB2-2	TB2-3	TB4-5
None	Sensor			Optional
S7	Sensor	Sig 1		Optional
S8	Sensor	Sig.1		Optional
S9	Sensor	Sig. 2		Optional
S10	Sensor		Sig.1 & 2	Optional
S11	Sensor		Sensor 1	Optional

Sensor Excitation Voltage Selection Links (Rev. B Only)

Excitation	Links
12v	S4
15v *	S5
3v3	S1
5v	S2
8v2	S3
Int. 3v3	S6
None	None

Notes:

Excitation Supply only available on '4-wire' version, except "Int. 3v3", which can provide limited power for sensor.

Some sensor types not compatible with 2-wire loop-powered version, unless externally powered.

*15V option may be factory modified for alternative voltages.

Rev.C & later: Sensors requiring power >3.3Vdc must be powered from External power source.

Operating Functions in the menu in a Hazardous Area

Various functions can be accessed using a magnet external to the housing and while the unit is still powered up. This enables the total to be reset (for example) without undoing the front cover.

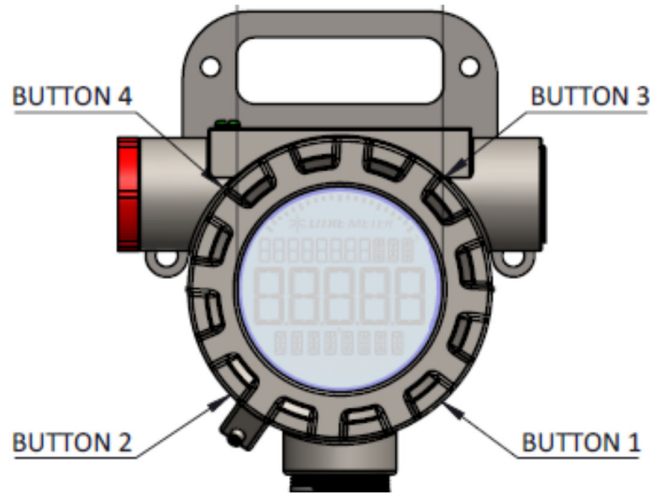

Totalisers Cycle through **Accumulated Total** (non-resettable), **Reverse Total**, and **Total** (default) using **Button 4**. Hold **Button 3** for 5 seconds to reset selected totaliser (display counts down during 5 secs). Reverts to default display after approx. 5 seconds.

Alarms **Button 2** will display active alarms in order of priority, with 5 second delay between. Returns to default display after last alarm display.

Memory Hold **Button 1** for 5 seconds to access Memory Card menu. Display shows "NO CARD" and reverts to default display if LM-MC memory card is not installed. Use **Button 3** to cycle through options. Use **Button 4** to select displayed option:

- Save Log Saves logged data to memory card.
- Load Sys Load calibration data to device from memory card.
- Save Sys Save calibration data from device to memory card.
- Restore Restores all configuration data from memory card to device.

Internal Memory In the event of corrupted memory that cannot be recovered by HART or External memory card, please contact factory for advice.