



## VFF SERIES ROTARY FLOWMETERS

### DESIGN & PRINCIPLE OF OPERATION:

These VFF series flowmeters are defined as rotary piston meters of a type as detailed in British Standard BS.7405:1991 which is a guide to flowmeters. They offer a wide metering range and can measure low and high viscosity fluids. For most of the flow range the viscosity may be varied with minor effect on the output characteristic.

Litre Meter provides a standard factory calibration representative of the application in terms of viscosity and flow rate range. A calibration certificate is provided which details the calibration fluid and viscosity, together with pulses per litre at a range of flow rates specifically for the application or the total meter range.

The only moving part of the flowmeter is the rotor which is equipped with a top mounted central magnet. The rotor oscillation is detected by a sensor or pair of sensors. The interaction between the magnet and a sensor does not impose drag on the rotor which could otherwise affect the low flow rate measurement capability. The certificate shows the number of active sensors. The reed-switch sensors are inherently intrinsically safe.

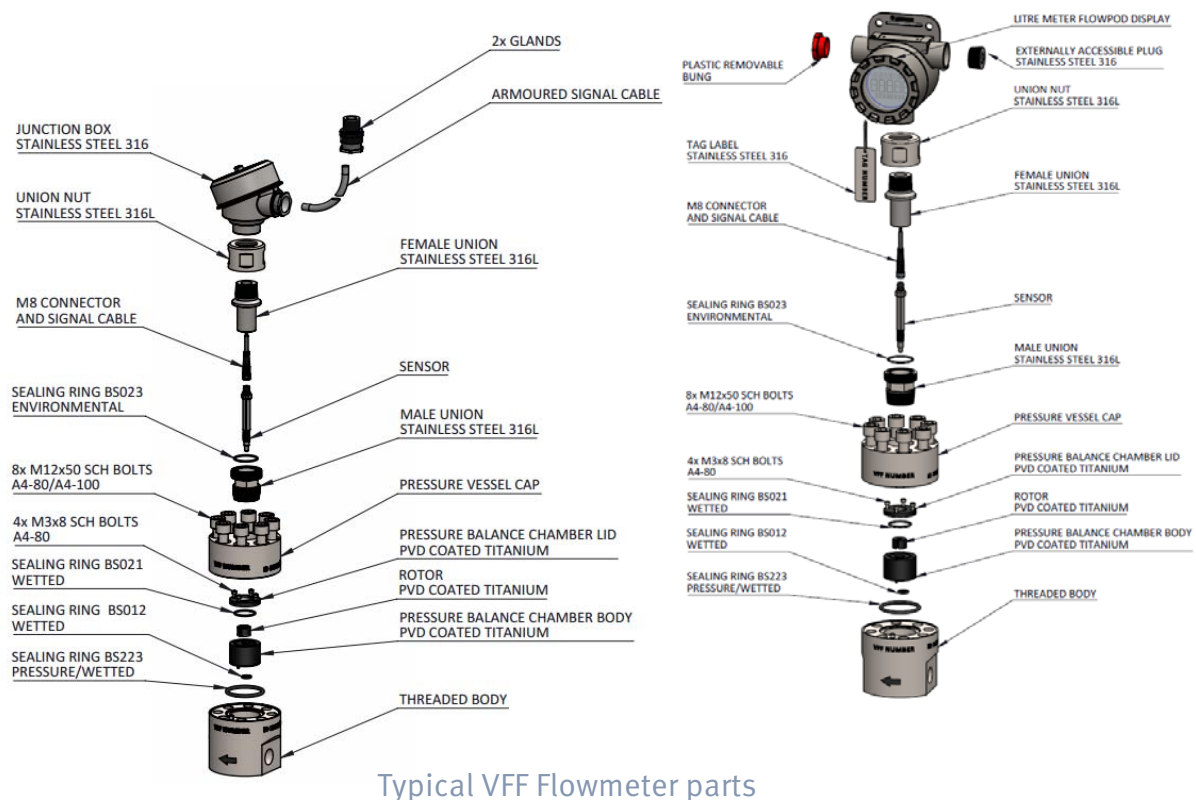

Typical VFF Flowmeter parts

THE METER MAY NOT BE DESIGNED FOR USE ON WATER – PLEASE CONSULT THE FACTORY. See *FAT Issues* on page 12.

tel: +44(0)1296 670200 - fax: +44(0)1296 670999 - email: sales@litremeter.com - web: www.litremeter.com

## Contents

DESIGN & PRINCIPLE OF OPERATION:.....	1
SPECIFICATION: .....	3
METER CONTENTS DESCRIPTION all as stated on the calibration certificate .....	3
MATERIALS:.....	3
FILTRATION:.....	3
Meter Size.....	3
FLOW PULSATION: .....	4
COMMISSIONING and START-UP: .....	4
MECHANICAL INSTALLATION: .....	5
Application Warnings: .....	6
INTRINSIC SAFETY Exi – Installation notes .....	7
FLAMEPROOF EExd – Installation notes.....	7
PRESERVATION .....	7
RECALIBRATION PERIOD .....	7
HANDLING AND SHIPPING PROCEDURES .....	8
HAZARDOUS AREA CERTIFICATION.....	8
FIELD WIRING CONNECTION & OUTPUT .....	8
METER MAINTENANCE – GENERAL.....	9
METER MAINTENANCE - TROUBLE SHOOTING.....	9
WEEE - Waste Electrical and Electronic Equipment .....	10
Measurement Principle: .....	11
What’s a pressure balanced chamber? .....	11
Key Benefits: .....	11
FAT Issues .....	12
On-Site Flowmeter Calibration.....	12
On-Site calibration.....	12
Precautions: .....	12
Flying start and finish.....	13
Standing start and finish .....	13
Installation .....	13
Commence the test.....	13
Calculations.....	13
<b>Appendix</b> .....	15

## SPECIFICATION:

**ACCURACY:** The accuracy of the flowmeter can be determined by the change in the pulses per litre value over a flow rate range selected from the calibration certificate. It should be noted that linearising electronics can follow the characteristic of the flowmeter thereby improving the overall system accuracy output of flow rate and totalisation. For severe pulsing flow, linearisation of the flowmeter signal may be impractical and two data points only should be used for minimum and maximum flow rate of the application.

**PRESSURE RATING:** The maximum service pressure is shown on the flowmeter calibration certificate. This meter conforms to all aspects of the Pressure Equipment Directive.

**TEMPERATURE RATING:** The minimum and maximum service temperature is shown on the flowmeter calibration certificate. If the minimum fluid operating temperature is to be below 0°C discuss this with the manufacturer. The ambient temperature can range from -40°C/-40°F to +75°C/+167°F (dependent on instrumentation).

**LIFE RATING – Sensor:** Litre Meter have carried out life testing on the latest reed sensor. At the current and voltage of a Fluidwell display they have successfully lasted over 15 billion operations representing 30 years continuous running at over maximum flow rate.

## METER CONTENTS DESCRIPTION all as stated on the calibration certificate

1. Flowmeter body or module with rotor chamber is as per the stock code.
2. The rotor.
3. O seals are provided to seal the pressure parts.
4. The top cap together with a number of bolts.
5. A single sensor is held in place using a simple M8 nut.
6. A male union protects the sensor assembly and is sealed with an O-ring for environmental protection to IP68. A cable with M8 electrical sensor connection connects to the display.
7. Optionally: A display integrally mounted on the union or separate through a junction box.

## MATERIALS:

In most applications Litre Meter use PVD coatings. These give stainless steel and titanium parts a distinctive anthracite grey colour. They provide excellent mechanical properties giving each flowmeter the capability of lower flow measurement, extended maximum flow and increased life. The actual coating material is not disclosed but is applied to a chromium nitride base layer. Extensive testing with an LF15 running at 90 l/hour for over two years show no signs of wear and achieved lower flow measurement. The PVD coating will improve the life expectancy of the meter for normal operation and will improve the flowmeters ability to withstand overrunning for short periods. Please note, that even with the PVD coating, long periods of overrunning will accelerate the wear process and result in poor performance or in some extreme cases may lead to meter failure.

## FILTRATION:

Positive displacement flowmeters do contain close tolerance moving parts and this applies to the VFF series flowmeters. However, Litre Meter has performed extensive independent and customer tests that show the VFF series is relatively immune from particles. Together with over 30 years of operating data Litre Meter recommends the following:

Meter Size	Filtration recommendation
VFF.LF03 and LF.05	40 microns
VFF.LF15 etc and larger	100 microns

### FLOW PULSATION:

The VFF series meters can be affected by pulsing flow rate particularly if there are severe flow rate variations in terms of the nominal flow. Sometimes a damping value can be utilized in the electronics to provide a smoother displayed value of flow rate.

Positive displacement meters 'follow' the flow rate changes and therefore may appear to give an unstable reading. A correctly chosen filter value in the instrumentation may be used to stabilise the meter reading and/or output.

### COMMISSIONING and START-UP:

Before commissioning and start up Litre Meter recommend that this entire manual is read. Pay attention to these sections:

[Mechanical Installation](#) and  
[FAT Issues](#).

Understanding the VFF flowmeter, previous customer experience and its operating parameters will greatly improve any Factory Acceptance Test but also ease commissioning and initial start-up.

## MECHANICAL INSTALLATION:

The end user of the equipment shall be responsible for the following actions during the installation of the equipment to ensure compliance with the Essential Safety Requirements (ESR) of the PED Directive 97/23/EC and 2014/68/EU. The relevant requirements of the PED are listed below:

PED ESR Ref	ESR Requirement	Compliance Requirement
2.3	<p><b>Provision to ensure safe handling and operation.</b> The method of operation specified for pressure equipment must be such as to preclude any reasonably foreseen risk in operation of the equipment. Attention must be paid, where appropriate, to the following:</p> <p>Devices to prevent physical access while pressure or vacuum exists.</p> <p>Surface temperature</p> <p>Decomposition of unstable fluids.</p>	<p>It is the end user's responsibility to ensure that the equipment is sufficiently protected from additional stress due to traffic, wind, earthquake loading, corrosion, erosion, fatigue, decomposition of unstable fluids, reaction forces and moments which result from the supports, attachment, piping etc. Pressures that exceed the meters maximum rating shown on the calibration certificates, Temperatures that exceed those shown on the calibration cert.</p> <p>The end user shall ensure that the flowmeter is installed in a properly designed system with access limitation in place if required.</p> <p>It is the responsibility of the end user to assess the expected surface temperature of the meter once in service, and if necessary, take the necessary precautions to avoid personnel coming into contact with the equipment.</p> <p>The end user should assess the risk and take any steps necessary to avoid the meter coming into contact with unstable fluids.</p>
2.4	<p><b>Means of Examination.</b> Pressure equipment must be designed and constructed so that all necessary examinations to ensure safety can be carried out.</p>	<p>Litre Meter VFF Flowmeters are designed so that all critical parts are contained within the meter body and cannot be examined while in service. The end user should refer to the operations and maintenance instructions supplied with each meter.</p>
2.5	<p><b>Means of draining and venting.</b> Adequate means must be provided to avoid harmful effects such as water hammer, vacuum collapse, corrosion and uncontrolled chemical reactions.</p>	<p>It is the responsibility of the end user to ensure that the meter is installed in a well-designed piping system to avoid such hazards.</p>
2.6	<p><b>Corrosion or other chemical attack.</b></p>	<p>The meter has been designed using materials that should not result in severe corrosion problems. It is the end user's responsibility to monitor any change in the process medium that may cause concern.</p>
2.7	<p><b>Wear.</b></p>	<p>It is not expected that the use of the meter for flow measurement will give rise to any abnormal wear problems. It is the responsibility of the end user to maintain the condition of the process medium.</p>
2.9	<p><b>Provisions for filling and discharge.</b></p>	<p>It is the responsibility of the end user to avoid hazards during filling and discharge.</p>
2.10	<p><b>Protection against exceeding the allowable limits of the pressure equipment.</b></p>	<p>The meter must be installed in a well-designed piping system with adequate protection against excessive pressure. – see also 7.3</p>
2.12	<p><b>External fire.</b></p>	<p>The meter has no special accessories for fire damage limitation. It is the responsibility of the end user to provide adequate fire-fighting facilities on site.</p>
7.3	<p><b>Pressure limiting devices, particularly for pressure vessels.</b></p>	<p>The VFF meter has no integral pressure limiting devices. It is the responsibility of the end user to ensure that it is installed in a well-designed system so that momentary pressure surges are limited to under 10% of the meter's maximum allowable pressure.</p>

All positive displacement meters are independent of pipe-work effects, and therefore valves, bends, tees, etc may be mounted directly onto the flowmeter process connections and the pipe size varied also. However, to provide optimum performance the meter body should be installed vertically with the process connections to a horizontal flow line. Screwed anchorages are provided on the underside of the flowmeter to support the meter and avoid pipe strains, etc. Signal connection is made via a junction box on top of the flowmeter or via the display. Vertical access should be provided for the field cabling connection and for maintenance purposes. Litre Meter do not recommend the meter is installed for vertically downward flow. The calibration certificate will confirm calibration orientation, if non-standard.

Care should be observed on start up to avoid high pressure drops across the flowmeter. The flowmeter can be specified with several rotor materials including carbon, titanium and stainless steel. There is a risk of the rotor or chamber damage if a high pressure drop or a high acceleration across the flowmeter is experienced. Typically, this may be caused by:

- \* Air in the line
- \* Opening a valve too quickly
- \* Purging with compressed air (or steam)
- \* A sudden introduction of fluid into an empty pipe

To prove the flowmeter is functioning without being installed in the line, it is possible to blow gently through the meter depending on meter size. You may be able to hear the rotor rotate and see the flow display. *Ensure that any dangerous fluids that may be in the meter are removed before this test.* Please do not use an airline as the rotor may be unknowingly damaged.

Blocking and Bypass valves should be installed if it is necessary to do preventative maintenance on the flowmeter without shutting down the flow system. The Bypass valve can be opened before the Blocking valves allowing the flow to continue while removing the flowmeter for service.

Important: All flow lines should be purged prior to installing the meter. To prevent possible damage to the meter, install the meter ONLY in flow lines that are clean and free of debris.

Upon initial start-up of the system a spool piece should be installed in place of the flowmeter so that purging of the system can be performed to remove all particle debris which could cause damage to the meter internals. In applications where meter flushing is required after meter service, care should be taken as to not over-speed the meter, as severe meter damage may occur.

Gas bubbles in the system will create measurement errors. These are purely volumetric meters.

#### Application Warnings:

Do not exceed the maximum temperature stated in the client data sheet

Do not exceed the minimum temperature stated in the client data sheet

Do not exceed the maximum pressure stated in the client data sheet. End user must ensure that a suitable device is fitted to prevent it from being exceeded.

No pressure surges to be allowed exceeding the maximum pressure stated in the client data sheet.

Only when correctly installed should the system be started. Operability must not be compromised during installation.

Misuse can be avoided. Please see the Essential Safety Requirements above.

Identified Hazards: Valves and pumps that induce shocks into the system etc.

Ensure glands are sealed and tightened, ensure Exd window is fully screwed down particularly in high humidity areas

The customer should not change the fluid without notification as this may damage the meter or invalidate PED certification (Pressure Equipment Directive).

## INTRINSIC SAFETY Exi – Installation notes

The reed-switch sensors do not require individual certification as they are classed as "simple apparatus". No marking of the meter regarding intrinsic safety is required under the relevant code. Reed-switches are covered under the Harmonised European Standards Clause 1.3 of EN50.014 and BS.5501 Part 1. These refer to devices that do not generate or store more than 1.2V, 0.1Amp, 20 microJoule and 25 milliWatt. They may be installed in a hazardous area relating to a classification EEx ia IIc T4. The reed-switch contact rating is 1VA with a switching voltage of 24V ac/dc with contact arrangement normally open form A. For the display please see the separate display instructions.

There is a technical construction file TCfoo4 containing an assessment against ATEX Directive 94/9/EC Annex 2 for installation as equipment Group II Category 1G EEx ia IIC T5 T<sub>amb</sub> = -40°C/+60°C. Suitability is confirmed by ignition hazardous assessments for both electrical and non-electrical equipment.

## FLAMEPROOF EExd – Installation notes

Mounted directly on the meter or indirectly is the IP66/IP68 enclosure providing rate and total display. Please see separate instructions.

Pulse Output: Without a display the raw output may be utilised externally via the junction box.

## PRESERVATION

Please note these flowmeters are generally constructed externally in stainless steel with stainless steel instrument housings. They are designed to be at least IP67 and are, therefore, suitable for mounting outside to that limit. We would normally recommend that the lowest temperature be -20°C. Please contact factory if this is likely to be lower. We would also recommend that no fluid be left in the flowmeter if there is a likelihood of the fluid freezing or setting. If some fluids leave residue, we recommend that these are thoroughly cleaned out before the units are stored. They will be shipped drained of calibration and test fluids. If they are to be left for extended periods of time without fluids, then the humidity should be controlled and either a preservative used inside the meter to prevent any corrosion effect or fully dried. Please ask the factory for advice. If the display cover is removed, we recommend maintaining the humidity at less than 40% RH to prevent component corrosion. We do not recommend that demineralised or de-ionised water is left in the meter for more than a few days. In some rare cases, there has been some attack on close-fitting surfaces. Either ensure the line is empty of fluid or use a preservation fluid.

## RECALIBRATION PERIOD

Recalibration periods of flowmeters are based on industry standards. In industrial applications, depending on the industry, periods of 6 to 12 months are recommended. Litre Meter advise the user to seek out data relating to the process, other components within the process and the usage of the meter. If the measurement is critical then the recalibration should be more frequent than a non-critical rarely used device. In the absence of any other data Litre Meter advise an annual check and to vary the future calibration periods depending on results.

If it has remained unused, then no recalibration will usually be necessary. It is wise to check that no fluid has settled in the measurement chamber that might alter the way the rotor rotates or even cause slight corrosion where two metal surfaces have been in close contact. Once cleaned the performance should remain unchanged.

## HANDLING AND SHIPPING PROCEDURES

The systems are packed entirely within wooden or cardboard boxes suitable for protecting the units during normal handling. We would recommend that they are kept in these boxes for as long as is practicable until they are finally required. One note of caution: please do not lift or handle the meters by solely lifting the display, glands or cables. If the display cover is removed, we recommend maintaining the humidity at less than 40% RH to prevent component corrosion.

## HAZARDOUS AREA CERTIFICATION

Please consult the instrument manual for details.

## FIELD WIRING CONNECTION & OUTPUT

Please see separate FlowPod Installation and Operating Manual LMo662 (or another instrument manual)

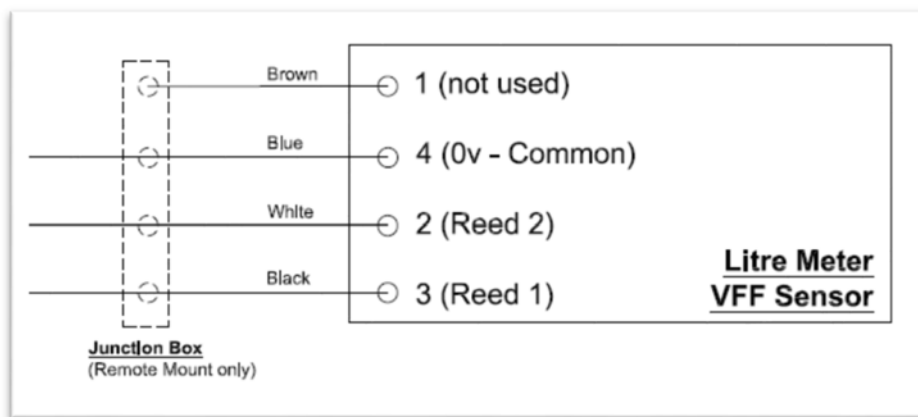

Refer to drawing depending on what has been supplied. The correct drawing is supplied with each order and can be accessed via the website url. The url is given on the quick start instructions and the outside of the flowmeter and instrument.

FlowPod drawing:

C7310 2 wire or C7311 for 4 wire

VRGS drawing

Refer to drawing depending on what has been supplied. The correct drawing is supplied with each order and can be accessed via the website url. The url is given on the quick start instructions and the outside of the flowmeter and instrument.

Fluidwell drawing – see Appendix

### Caution:

**Meter disassembly, assembly, modification etc should only be carried out by qualified personnel.**

## METER MAINTENANCE – GENERAL

This unit should not require regular maintenance providing the installation precautions above are taken into consideration. The warranty will not be invalidated if the cap is removed to inspect the rotor and its chamber. Document LMO638 lists all the possible failure scenarios and resolutions and to some extent, probabilities – see also the FAT Issue section in this manual, p12.

## METER MAINTENANCE - TROUBLE SHOOTING

1. If the display or receiving equipment fails to register pulses, first check the display and/or the receiving equipment by shorting out a pair of input terminals to check for function. (This duplicates the action of the reed switch). Access is gained to the sensor through the process described below: **If the reed sensor is tested for continuity please ensure a maximum of 10mA (0.01A) is applied.**

1.1.1. Undo the display cover.

1.1.2. The display disc assembly will then be loose enough to remove, just held by a ribbon cable. The sensor will still be attached and connected to one of the terminal blocks (TB2).

1.1.3. Remove the wires from TB2. Connect two new wires to TB2 using Sig1 and Set2. Short these two wires together a number of times – this duplicates the action of the reed switch. Help is available at the factory. If the shorting makes the display count, then it is likely there is either a problem inside the chamber or with the sensor itself.

1.1.3.1 To replace the sensor undo the nut to loosen the existing sensor.

1.1.3.2 Gently undo the sensor body to remove the sensor.

1.1.3.3 Replace with the new sensor ensuring that **a) the sensor is located at the bottom of its hole and b) the nut locks the sensor in place**

1.1.4. Reassemble ensuring that the sealing O-rings are kept in place and wiring is re-connected.

1.2 If the instrumentation responds then the next step is to check the wiring between the reeds and the display (which may also contain a pulse repeater such as a galvanic isolator used for intrinsically safe systems). (*Integral display– ignore this step*)

1.3 If shorting the field wire connections sequentially produces a result at the display, then it is likely there is either a problem inside the chamber or with the sensor itself (less likely). (See para 1.1.3 above for assistance on this)

1.4. The first check avoids breaking down the liquid seal of the flowmeter.

1.4.1 Undo the M8 nut and undo the reed sensor. Moving a magnet in front of this will duplicate the action of the flowmeter. Replace if necessary. Tighten the nut ensuring the reed

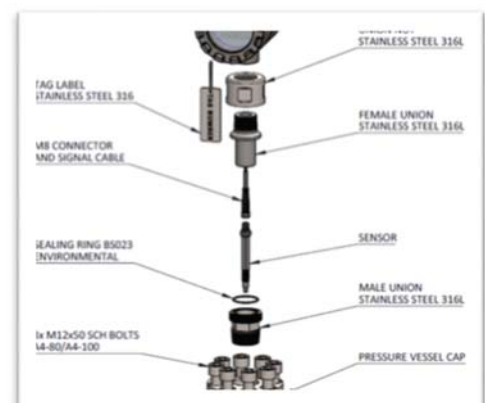
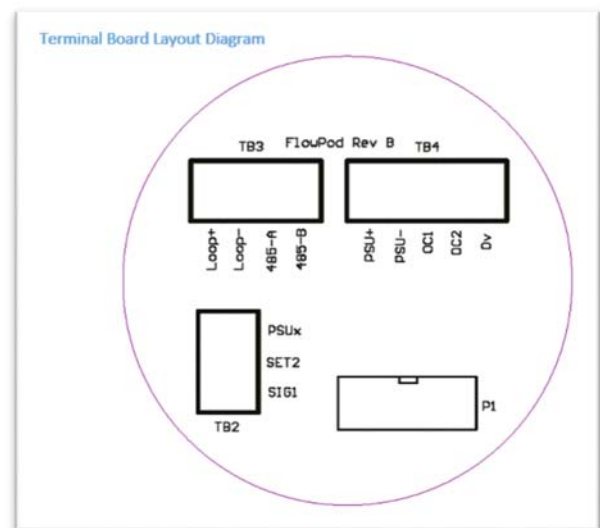

sensor is held at the end of the sensor hole.

2. If it is seen that there is no sensor output by the above procedures and it is certain that flow is taking place, then it is possible that the rotor has become jammed due to the presence of a foreign body/particle. The sensor output may be a continuous 'low' state or a 'high' closed contact state of signal if the magnet is stationary under a reed switch. The meter may be disassembled in the following manner.

Ensuring that the line pressure is off, and the line is drained as necessary, remove the socket cap screws of the flowmeter cap (the sensor may be left in place during this procedure). The top cap can now be removed from the flowmeter body. [In some instances, the rotor is exposed. If not, the rotor can be accessed by undoing the socket cap screws presented.] It is likely that the rotor is stuck. Extract the rotor vertically (taking care that the operator is not contaminated with the process fluid). Observe both the rotor and the rotor chamber for debris or particles. Clean both the rotor and the rotor chamber. With the rotor free from the flowmeter, the rotor can be placed against the top cap. Run the rotor in a circular motion to check the output from the sensor system. Ideally this should duplicate the action of the rotor in its chamber. Having verified that an output is taking place, the rotor can be replaced in the rotor chamber. Replace the rotor and check that it oscillates freely. Ensure that the O-ring is undamaged and place it in its groove in the top cap. Reassemble the top cap taking care to tighten the socket cap screws. If applicable, re-assemble the top cover, bracket and enclosure.

3. Check that suitable filtration is present in the upstream pipe work to the flowmeter. Employ a smaller micron mesh filter if necessary.

If appropriate see the separate instruction for the display unit.

## WEEE - Waste Electrical and Electronic Equipment

Litre Meter Ltd has a formal product disposal Take-Back and Recycle Program in Europe that complies with the European Union Directive 2012/19/EU on waste electrical and electronic equipment, also known as the "WEEE Directive".

This program provides self-service instructions for ease of use product take-back and recycling. Equipment that is returned through this program will be handled in an environmentally safe manner using processes that meet or exceed the WEEE Directive requirements. This program is for Litre Meter customers who have Litre Meter and other manufacturer's flowmeters that have been supplied by Litre Meter that have reached the end of life.



WEEE - Please contact us to initiate a return request. See our policy on the website.

## Measurement Principle:

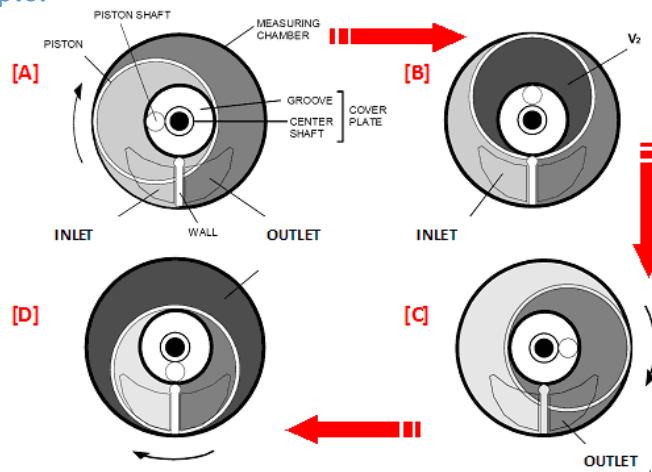

Figure 1 Measurement Principle

The flow causes the rotor to move within the measuring chamber. This movement is sensed, giving an output representing an increment of volume flow. The rotor is basically a disc shape with an annular groove on its underside capable of holding and transporting flow from the chamber inlet to the outlet. Some fluid is also transported in a cavity formed between the rotor outside wall and the chamber wall. A centre 'peg' under the rotor is constrained to run in a circular groove in the body. A web (or plate) in the body is engaged with a slot in the rotor and this modifies the rotation to that of an oscillation as flow passes. It is this oscillation that produces the compartmentation of the fluid into 'positively displaced pockets'. The top of the rotor is equipped with a powerful magnet directly above the 'peg' that is on the underside and so this also has a circular path which allows it to engage and disengage a reed switch sensor located in the top cap above. A volt-free contact closure output signal is given for each oscillation which represents a volume increment. The fluid is transported in a 'positive' manner always. The typical metering repeatability is better than 0.2% and a meter accuracy of 1% actual reading is usually obtained over a substantial flow range. For lowest flows the meter will under-read the actual flow in a consistent manner. This allows an improved wide-range system accuracy to be gained using a linearising electronics instrument such as the Litre Meter FlowPod.

## What's a pressure balanced chamber?

Extensive testing by Litre Meter in 2005 proved that leaks occur over the top of the rotor at higher pressures. This is due to minute distortions of the cap. For example, at 700bar the cap moves by just 0.02mm in the centre. Increasing the bulk of the cap still produces this movement. The effect on meter performance was the creation of a leak path for fluid that avoided the positive displacement of the rotor. This was equivalent to about a 3% inaccuracy at 700bar. Because of this Litre Meter designed a special pressure balance chamber for its VFF flowmeter so it could operate at extreme pressure and at low-flow rates. The pressure balance chamber acts as a barrier, protecting the internal measurement components of the instrument from the high pressure conditions, preventing them from expanding and contracting under the immense pressure. All VFFs over 414bar are fitted with this technology. It is identified by the letters PBC in the calibration certificate.

### Key Benefits:

- \* No distortion of the chamber at higher pressures.
- \* No measurement inaccuracy due to pressure.
- \* Enables selection of optimal materials for the chamber to match the rotor i.e. PVD coated stainless steel.
- \* Enables selection of optimal materials for the pressure vessel. i.e. super duplex stainless steel
- \* Enables construction of a duplex bodied flowmeter – duplex material does not lend itself to the tolerances required in machining the chamber.

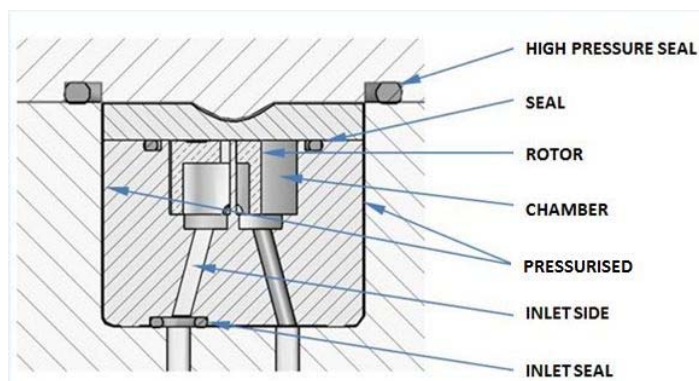

## FAT Issues

The Factory Acceptance Test can be the first time the meter is run after being despatched from the factory. Here are some common problems encountered and their resolution:

- 1 The most frequently used FAT fluid is water. This won't damage the meters at all, but it does have a very low viscosity. There are two significant effects. Firstly, the meter will probably not measure as low as the flow rates achieved at time of factory calibration. The calibration viscosity is taken to be the viscosity of normal operation. Secondly, if it does operate at the lowest flows, then the accuracy may be greatly reduced. It is likely to under-read by up to 30%. The solution is to change the FAT fluid. The addition of glycol or replacement by glycol for the FAT is quite common.
- 2 Dirt in the system is hard to avoid. Even with filtration at 40 or 100 microns it is still quite easy for potentially blocking particles to be held in the piping, even after flushing. We would recommend the meter is taken out of line before pipe flushing. Items like PTFE tape and the remnants of thread locking compounds will prevent the rotor from turning. However, the rotor and chamber can be simply cleaned by disassembly and washing.
- 3 Installation attitude can be different from original calibration. The meters are normally calibrated in a horizontal line with the meter installed upright. If a different orientation is advised or used it will be noted on the calibration certificate. There will be some small functional differences if the meter is installed on vertically upward flow or upside down. Litre Meter do not recommend the meter is installed for vertically downward flow. Performance at the very lowest flows may be compromised unless calibrated in the correct orientation.

An error analysis system is described in document LM0638, *VFF Fault Finding*.

## On-Site Flowmeter Calibration

This procedure must be integrated with the approved Health and Safety policy at site.

The purpose of this section is to outline a general calibration procedure for various flowmeters. It will make specific reference to volumetric flowmeters but most of the principles are equally applicable to other flow measurement technologies. The important consideration is that there is access to the reading of the Meter Under Test (MUT) and a sufficiently accurate understanding of the actual flow rate.

### *On-Site calibration*

The aim of this calibration technique is to provide data to the user such that the instrumentation can be adjusted to show the correct flow rate and/or total

This will be done by

- maintaining a known flow rate and
- monitoring the output of the MUT

### *Precautions:*

- Flush/Clean piping prior to installing the meter or any pipework changes
- Ensure that a liquid system has no air or vapour entrained
- Ensure that the flow variations during testing are at a minimum, usually better than  $\pm 1\%$  variation
- Ensure there are no protruding gaskets upstream of the meter (for turbine meters etc.)
- Measure the piping to ensure that dimensions and finish are within standard limits
- Ensure that the measurement equipment is installed in accordance with standards or to the manufacturer's recommendations

This is how Litre Meter calibrate flowmeters in the factory:

#### CALIBRATION

Most Litre Meter flowmeters are calibrated using a gravimetric method. A flow rate is established through the flowmeter with the output flow returning to the main reservoir. At the commencement of test, the output flow is diverted into a weigh tank. When sufficient volume of fluid has been collected in respect of that flow rate, the output flow is diverted to the main reservoir once more. The time for the volume of fluid to be collected is recorded, together with the number of pulses produced by the transmitter. The density of the fluid is determined at time of calibration. Volume divided by time equals flow rate. The number of pulses divided by volume equals the pulses per litre Meter Factor. The calibration certificate is prepared from a table of these values. If on-site calibration is required and a known volume of fluid flow can be established, then the same calculations apply to reproduce the calibration certificate.

- Avoid pulsating flow and cavitation to have meaningful results

**Prepare a weigh tank.** The tank should be of sufficient size to contain a volume of fluid running at the required range of flows for a minute or so. For example, if the meter has a flow range from 1 to 30 litres per minute then a 30 litre tank would be appropriate. As the tank may be difficult to empty completely having it a little larger is advisable; care should be taken that it is deep enough or so shaped that splashing outside of the tank doesn't occur. The tank needs to be weighed before and after the test to sufficient accuracy. For lower flow rates there is not necessarily a requirement to measure 30 litres each time. This will depend on other factors such as weigh scale resolution, accuracy of weigh scale, accuracy of flowmeter and accuracy of density determination. This method is normally used for water where the density is well known as it measures mass but will be applied to volumetric flow meters. As guidance Litre Meter recommends a weigh scale with a resolution 10,000 times smaller than the maximum weight and a densitometer accurate to the  $\pm 0.001 \text{ g/cm}^3$  (if water isn't used). In some instances, a volumetric tank could be used where the volume is accurately known.

**Prepare start and end of test.** There are two options:

#### *Flying start and finish*

This method is very widely used when flow rate meters must be calibrated with water. It is perhaps less appropriate for the calibration of volumetric meters, or for meters which are being calibrated with oils or fuels. The mass flow rate is calculated by dividing the mass collected in the tank by the diversion time, and this can be converted to a volumetric flow rate by dividing it by the density at the appropriate temperature. A diversion is caused by switching the stream of fluid into a weigh tank at the start of the test and reversing the switch at the end of the test. Accuracy of calibration is obtained by ensuring the timing error at the start and end is minimised by both good technique and by relatively long test periods (at least 60 seconds, for example) and repeatable, quick diversion.

#### *Standing start and finish*

Is simpler than flying start but the following errors can occur:

- Ensure that the MUT is full prior to testing; a rush of air can lead to large errors.
- If the start system is relatively slow there may be a significant part of the test which is at a varying flow rate – the same applies for the end portion. Timing may be hard to calculate.

If it is intended to use a standing-start-and-finish method of calibration, it is probably better to use a weigh scale if the test fluid is water or a viscous oil (above, say, 5 cSt), and to use a volumetric tank with low viscosity hydrocarbons (below, say, 5 cSt).

#### *Installation*

- If not already installed; install MUT into piping. Tighten all pipes/flanges to avoid leaks. Select appropriate pipe work for each meter style; use markings on meter for flow direction and orientation. Ensure meter is centred within pipework.
- If not already connected electronically; connect display to meter. Ensure display is set to show either
  - total or
  - flow rate
  - Alternatively pulses or an analogue signal can be measured
- Before commencing test make sure weigh tank is empty or nearly empty. Close valve and tare scales to show zero.
- Switch on pump and control flow
- Reset total on display (if only flow rate display is available, note the value for the duration of the test and calculate the average at the end of the test)

#### *Commence the test*

- Either divert the flow or commence the flow.
- When the tank has reached the specified weight (or time) then divert the flow back or stop the flow. Record the weight/volume, empty tank as necessary, rest the weigh scale.
- Repeat for each flow rate as required – factory calibration normally covers from minimum flow rate to maximum flow rate in 8 steps but if the usage is over a different or reduced range than that should be reflected in the calibration flow rates. Additional confidence can be gained by repeating the tests at each flow rate.
- Finish calibration
- Assess MUT performance

#### *Calculations*

- Compare either: the actual flow rate i.e. the mass or volume divided by the length of the test against the displayed flow rate
- Or: the total collected against the displayed total or calculated total.
- Create a table of results over the range of flow rates used.
- Using the manufacturers original calibration certificate recalculate any data into new 'points'. This assumes that a set of linearization data has been entered originally into the instrumentation. (In some cases, a single meter factor is used. The table of results can be used to provide an average meter factor over the range of flow rates tested which will provide a better series of readings once modified.)
- Enter the new data into the instrumentation
- Ideally, run the tests again to check the results over a few of the flow rates and confirm the calculations.

Calculation examples can be found on the next page:

Data Collection

	A	B	C	D	E	F	G	H
1	Test #	Approx flow rate	Weight collected	Time for test	Density	Calculated Volume	Displayed Flow rate	Actual flow rate
2		Litres/hour	Kg	Seconds	gm/cm <sup>3</sup>	Litres		Litres/hour
3						<u>Col C</u>		<u>Col F*3600</u>
4						Col E		Col D
5								
6	1	1500	25.106	60.015	1.0015	25.068	1500	1503.73
7	2	1500	24.976	59.866	1.0015	24.939	1495	1499.66
8	3	1500	24.807	59.432	1.0015	24.770	1492	1500.39
9								
10	4	1200	15.887	44.215	1.0015	15.863	1245	1291.59
11	5	1200	16.015	43.965	1.0015	15.991	1240	1309.40
12	6	1200	15.757	44.023	1.0015	15.733	1233	1286.61
13								
14	7	Etc.						
15	8	Etc.						

Data Analysis

	A	B	C	D	E	F	G	H	I
16	Data Sets						Displayed Flow rate	Actual flow rate	Difference
17									(Col G/Col H)-1
18	Average of tests 1, 2 and 3						1495.667	1501.262	-0.37%
19	Average of tests 4, 5 and 6						1239.333	1295.863	-4.36%
20	Average of tests 7, 8 and 9								
21	Etc.								Etc.

Original Data

Revised Data, after calibration

	A	B	C	D	E	F	G	H	I
22		Flow Rate	Meter Factor			<b>New Flow Rate</b>	<i>Old</i>	Difference	<b>New</b>
23	Run	Litres per hour	Pulses per litre		Run	<b>Litres per hour</b>	<i>Pulses per litre</i>	was	<b>Pulses per litre</b>
24	#	l/hr	ppl		#	<b>l/hr</b>	<i>ppl</i>		<b>ppl</b>
25									Col G x(1+Col H)
26	1	1686.06	851.815		1	<b>1501.262</b>	851.815	-0.37%	<b>848.640</b>
27	2	1237.26	850.707		2	<b>1295.863</b>	850.707	-4.36%	<b>813.596</b>
28	3	918.06	851.688		3			Etc.	
29	4	603.90	857.140						
30	5	484.314	868.801						
31	6	363.030	879.710						
32	7	244.398	890.983						
33	8	127.716	918.669						
34	9	53.412	941.109						

## Appendix

### *Fluidwell wiring – please also see separate wiring diagram*

Refer to drawing depending on what has been supplied. The correct drawing is supplied with each order and can be accessed via the website url. The url is given on the quick start instructions and the outside of the flowmeter and instrument.

#### **Integral Fluidwell Exi (F112, F118, Fo18 etc) display:**

Connection of field wiring is simple.

1 – If the M20 gland thread is provided in the cover.

Remove the front of the display and feed the cable through the gland, up the stem and connect to the terminals as shown in the other instructions.

2 – If the M20 thread is not provided, remove the front of the display and undo the nut holding the instrument back box to the cover. Drill a 20mm clear hole in the desired position on the back box - depending on field orientation. Feed the cable through the gland, up the stem and connect to the terminals as shown in the display instructions.

#### **Remote Fluidwell Exi (F112, F118, Fo18 etc) display:**

Connection of field wiring is simple. Remove the quantity 4 M4 socket cap head screws retaining the top cover to the cap. Remove the cover and pass through 2-wire customer field cabling. Use a connector and attach it to the 2-wires of the field cabling. Ensure that the O-ring is in place on the top cap surface. Lower the top cover onto the flowmeter top cap carefully over the O-ring and reassemble using the M4 socket cap bolts. Draw down the gland provided by others and fit to the thread provided in the top housing. Ensure field cabling is not straining the connector within the cover; clamp the gland to the field cabling. The installation is now complete.

**Exi display 4-20mA output option** enables the unit to transmit a flow rate signal. This is optionally available through the M20 gland on the side. It may be necessary to make the gland hole in the instrument housing. This should be wired up as follows (Fluidwell display):

1. Remove the four counter-sunk screws on the display front.
2. Pull out the green 7-way adaptor plug.
3. Undo the M14 nut inside the display box and remove box.
4. There are four wires from the display. The two blue wires are the flowmeter signal. The red and green wires (if fitted) are for the 4-20mA output. The terminals are also marked (+) and (-). From the flowmeter body there are four wires. One pair is the active reed switch, other pair not utilized (see Field Wiring section above). (See page 38 of the display instructions for a wiring diagram of the display; Section 5 Configuration Example 3).
5. Reassemble the cover with the four cap bolts ensuring that the sealing O-rings are kept in place.
6. Reassemble the display box onto the cover using the M14 nut.
7. Re-engage the 7-way adaptor plug and re-secure the instrument front with the four counter-sunk screws. The flowmeter is now ready for operation.

**To prove the flowmeter is functioning without being installed in the line, it is possible to blow gently through the meter. You should be able to hear the rotor rotate and see the flow display. *Ensure that any dangerous fluids that may be on the rotor assembly are removed before this test.* Please do not use an airline as the rotor will be unknowingly damaged.**