

FM4100



USER MANUAL V1.5

Table of Contents

ATTENTION!.....	2
INSTRUCTIONS OF SAFETY	3
LEGAL NOTICE.....	4
Short description	5
1.1 About the document.....	5
1.2 Acronyms.....	5
1.3 Mounting guidelines	5
2 Package contents.....	6
3 Main Features.....	7
4 Mechanical features	8
4.1 Navigation LED.....	10
4.2 Modem LED	11
4.3 Status LED.....	11
5 Connection & pinout.....	12
5.1 Socket 2×10	12
5.2 PORT 1/NMEA	13
5.3 Audio port.....	13
5.4 1-Wire® devices	14
6 ACCESSORIES.....	15
6.1 Temperature sensor TTJ-101	15
Technical support.....	17
7 Changes Log Sheet	18

ATTENTION!



Do not disassemble the device. Do not touch before unplugging the power supply if the device is damaged, the power supply cables are not isolated or the isolation is damaged.



All wireless data transferring devices produce interference that may affect other devices which are placed nearby.



The device may be connected only by qualified individuals.



The device must be firmly fastened in the predefined location.



The programming must be performed using a second class PC (with autonomic power supply).



The device is susceptible to water and humidity.



Warning!! May explode, if a wrong accumulator is used.

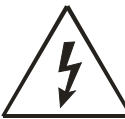

Any installation and/or handling during a lightning storm is prohibited.



INSTRUCTIONS OF SAFETY

This chapter contains information on how to operate “FM4100” safely. BY following these requirements and recommendations you will avoid dangerous situations. You must read these instructions carefully and follow the strictly before operating the device!

The device uses a 10V...30V DC power supply. The nominal voltage is 24V DC. The allowed range of voltage is 10V...30V DC, power – not more than 12 W.

To avoid mechanical damage, it is advised to transport the FM4100 device in an impact-proof package. Before usage, the device should be placed so that its LED indicators are visible, which show what status of operation the device is in.

When connecting the connection (2x10) cables to the vehicle, the appropriate jumpers of the power supply of the vehicle should be disconnected.

Before dismounting the device from the vehicle, the (2x10) connection must be disconnected.

The device is designed to mount in a zone of limited access, which is inaccessible for the operator. All related devices must meet the requirements of standard EN 60950-1.

The device FM4100 is not designed as a navigational device for boats.



LEGAL NOTICE

Copyright © 2007 Teltonika

All rights reserved. Reproduction, transfer, distribution or storage of part or all of the contents in this document in any form without the prior written permission of Teltonika is prohibited.

1-Wire is a registered trademark of Dallas Semiconductor.

Other products and company names mentioned herein may be trademarks or trade names of their respective owners.

SHORT DESCRIPTION

FM4100 is a terminal with GPS and GSM connectivity, which is able to determine the object's coordinates and transfer them via the GSM network. This device is perfectly suitable for applications where location acquisition of remote objects is needed. It is important to mention that FM4100 has additional inputs and outputs, which let you control and monitor other devices on remote objects. 1-Wire® interface (for Dallas digital thermometer or I-Button reader) and CAN interface integrated (for trucks FMS interface data acquisition). It also has a RS232 port for NMEA output and configuration (also it could be used for peripheral devices communication with special firmware).

1.1 About the document

This document contains information about the architecture, possibilities, mechanical characteristics of the FM4100 device.

1.2 Acronyms

PC – Personal Computer.

GPRS – General Packet Radio Service.

GPS – Global Positioning System.

GSM – Global System for Mobile Communications.

SMS – Short Message Service.

AC/DC – Alternating Current/Direct Current.

1.3 Mounting guidelines

The device is mounted in the predefined location in the object by attaching it using a two-sided tape and additionally securing using three plastic 300x4 mm straps. If there is no possibility of mounting the device in the predefined location as written above, alternative mounting methods may be applied, securing the stable position of the device.



2 PACKAGE CONTENTS

The FM4100 device is supplied to the customer in a cardboard box containing all the equipment that is necessary for operation. The package contains:

1. The FM4100 device.
2. Input and output power supply cable with a 2x10 connection.
3. GPS and GSM antennas.
4. Port 1/2 and Port 3 cables

Supplements:

1. Temperature sensor TTJ-101 (by order).

Note: the manufacturer does not supply a SIM card in the package, which is necessary for connection to the GSM network! SIM card can be obtained from Your local GSM service provider!

If any of the components is not in the package, please contact the manufacturer's representative or the vendor. (www.teltonika.lt)

3 MAIN FEATURES

- ✓ Track your remote objects (trucks, cars) quickly and easily.
- ✓ The device supports the following GSM bearers:
 - GPRS class 10 (up to 44,8 kbps).
 - SMS (text/data).
- ✓ Quad-band:
 - European (and Asian) - 900 MHz / 1800 MHz and American - 850 MHz / 1900 MHz.
- ✓ The aluminum case of the device is very robust and perfectly suitable for installation into harsh environment such as cars, trucks or other moving objects.
- ✓ On demand internal rechargeable battery with charge controller.
- ✓ FM4100 has 4 digital inputs, 4 digital outputs and 4 analogue inputs, which could be used for performing of various tasks on remote objects, such as monitoring fuel tank level, engine status, or controlling truck door etc.
- ✓ FM4100 has 1-Wire® I/O protocol integrated for temperature measuring or key identification.
- ✓ FM4100 has CAN bus interface that could be used for data acquisition from truck's FMS interface.
- ✓ FM4100 has NMEA output via RS232 that could be used for navigation purposes.
- ✓ 3 LED indicators: "Modem", "Status" and "Navigate".
- ✓ An advanced solution for a very reasonable price.

4 MECHANICAL FEATURES

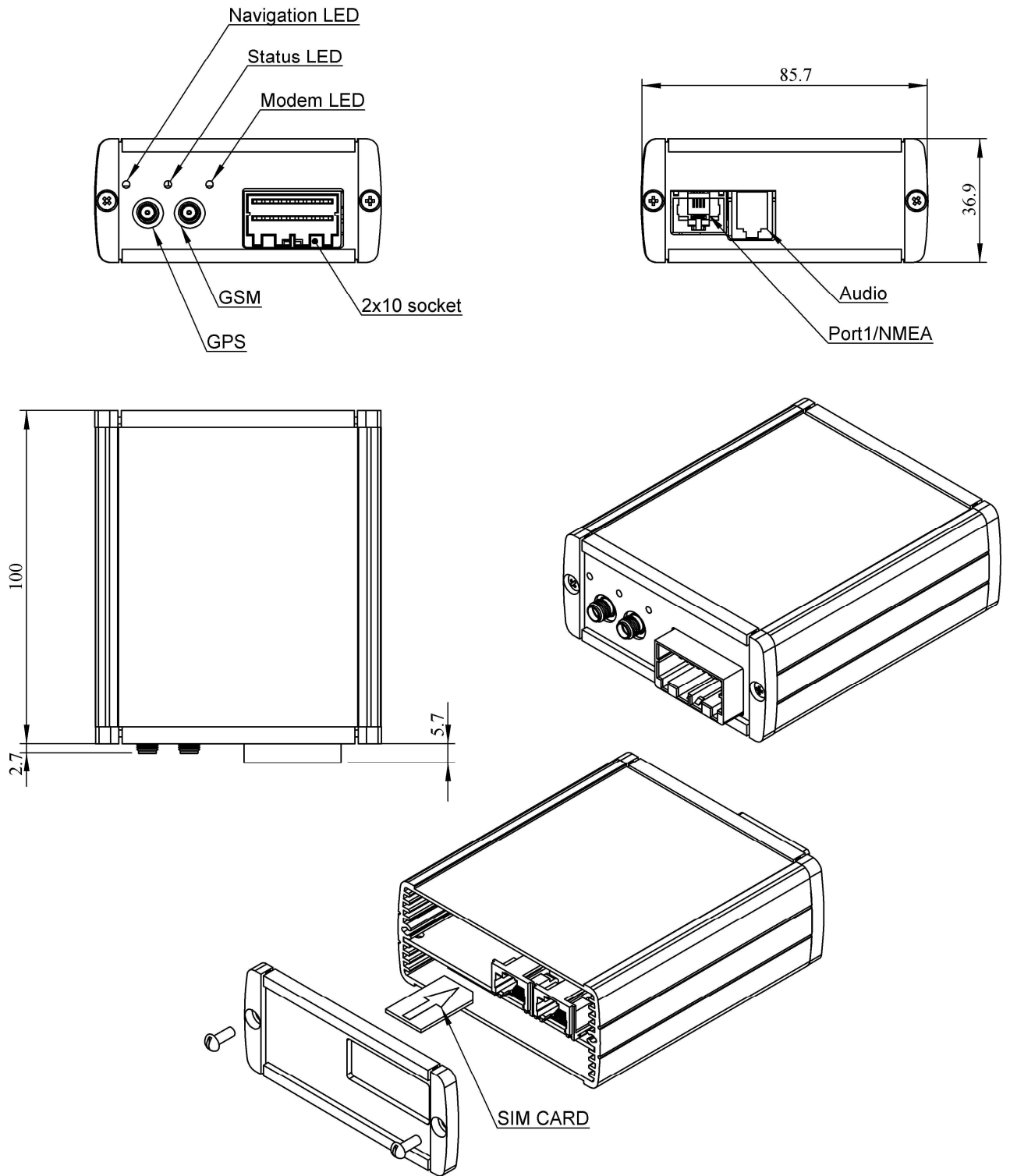

All the dimensions in millimeters, tolerance ± 0.5 mm

OR

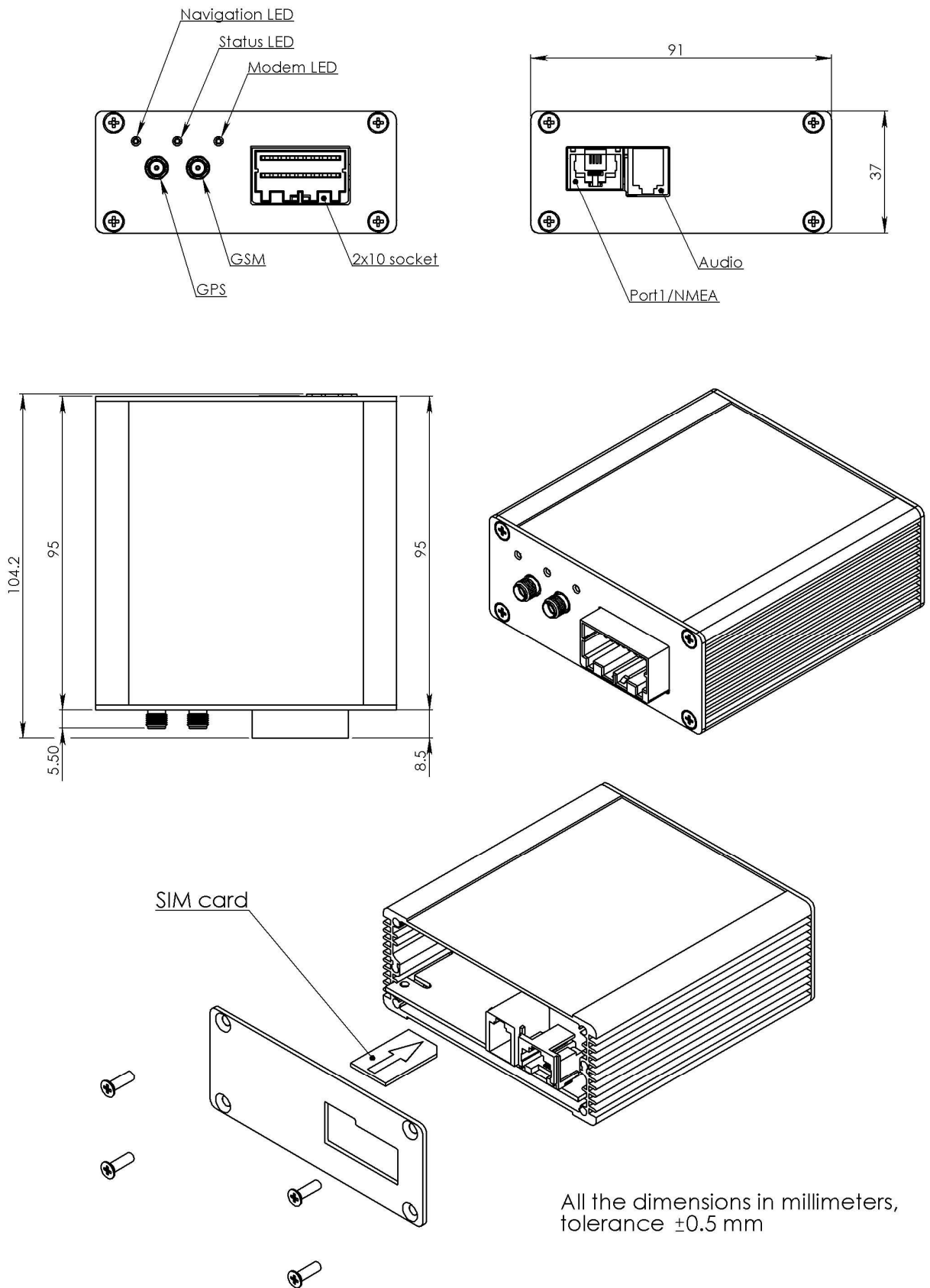

Figure 1. FM4100 drawing & spec , two enclosures

Part name	Physical specification
Navigation LED	LED
STATUS LED	LED
MODEM LED	LED
GSM	GSM antenna connector SMA
GPS	GPS antenna connector SMA
Socket 2×10	Tyco Multi-Lock I/O MK-II C-175975
SIM	GSM SIM card socket
PORT 1/NMEA	RJ45 8 pin socket
AUDIO	RJ11 4 pin socket

Technical details
Power supply 10...30 V DC 12W Max
Energy consumption: GPRS: --- 250 mA r.m.s Max., Nominal: --- 110 mA r.m.s..
Operation temperature: -25°C ... +55°C
Storage temperature: -40°C ... +70°C
Relative humidity 5 ... 95%

4.1 Navigation LED

When GPS signal is not received, the **Navigation LED** is blinking as follows:

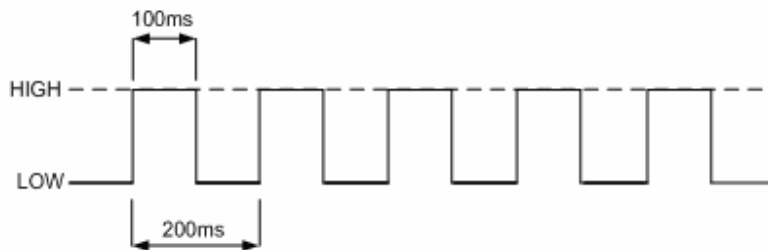

When GPS signal is received, the **Navigation LED** is blinking as follows:

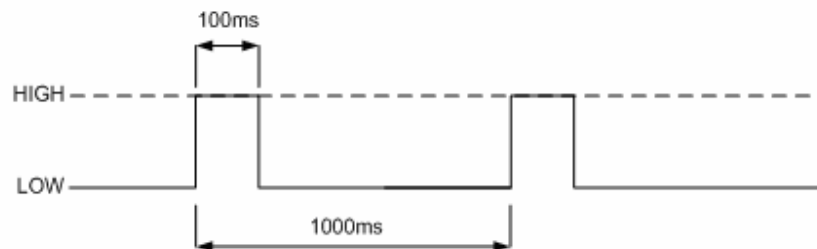

When **Navigation LED** is off, that means a short circuit is GPS antenna or connector.

4.2 Modem LED

When device is connected to the GPRS – Modem LED is blinking every second:

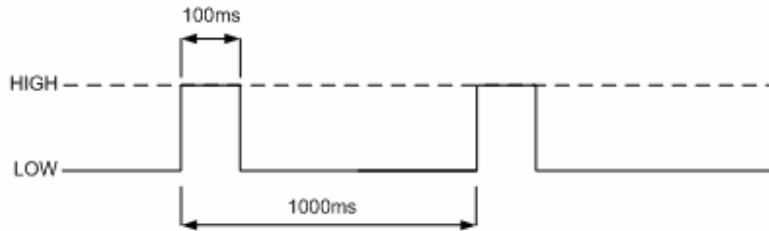

When device is not connected to GPRS – Modem LED is blinking every 5 seconds.

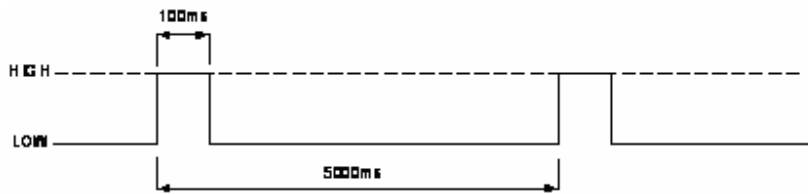

4.3 Status LED

When device has uploaded firmware – Status LED should blink. If LED does not blink – it means that device does not function.

5 CONNECTION & PINOUT

5.1 Socket 2x10

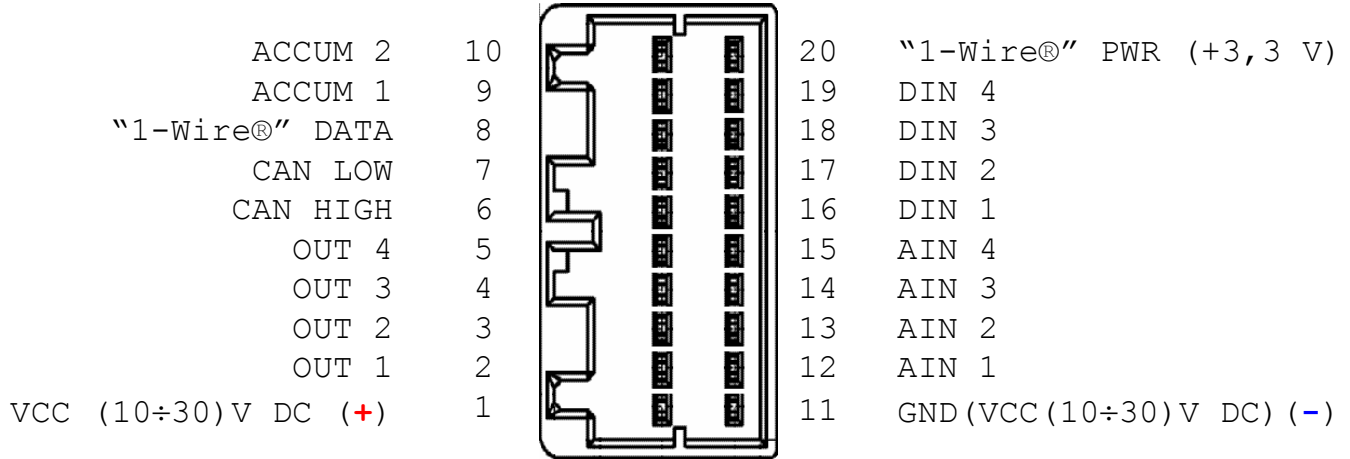
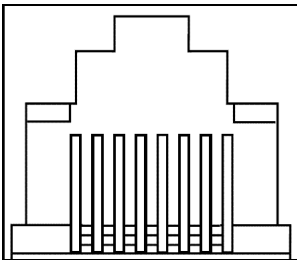

Figure 2. 2x10 socket pinout

Pin Nr.	Pin Name	Description
1	VCC (10÷30)V DC (+)	Power supply for module. Power supply range (10...30) V DC Energy consumption: GPRS: --- 400 mA r.m.s Max., Nominal: --- 100 mA r.m.s..
2	OUT 1	Digital output. Channel 1. Open collector output. Max. --- 500mA.
3	OUT 2	Digital output. Channel 2. Open collector output. Max. --- 500mA.
4	OUT 3	Digital output. Channel 3. Open collector output. Max. --- 500mA.
5	OUT 4	Digital output. Channel 4. Open collector output. Max. --- 500mA.
6	CAN HIGH	SAE J1939 CAN interface High channel
7	CAN LOW	SAE J1939 CAN interface Low channel
8	"1-Wire®" DATA	Data channel for Dallas 1-Wire® devices
9	ACCUM 1	This pin is used connected with pin ACUM 2. Function of those pins is to disconnect the internal accumulator during shipment or storage. When ACUM 1 and ACUM 2 are connected, the internal accumulator is on, while disconnected - the internal accumulator is off.
10	ACCUM 2	This pin is used connected with pin ACUM 1. Function of those pins is to disconnect the internal accumulator during shipment or storage. When ACUM 1 and ACUM 2 are connected, the internal accumulator is on, while disconnected - the internal accumulator is off.
11	GND (VCC (10÷30)V)	Ground pin. (10÷30)V DC (-)

	DC) (-)	
12	AIN 1	Analog input, channel 1. Input range: 0-10V DC
13	AIN 2	Analog input, channel 2. Input range: 0-10V DC
14	AIN 3	Analog input, channel 3. Input range: 0-10V DC.
15	AIN 4	Analog input, channel 4. Input range: 0-10V DC
16	DIN 1	Digital input, channel 1
17	DIN 2	Digital input, channel 2
18	DIN 3	Digital input, channel 3
19	DIN 4	Digital input, channel 4
20	"1-Wire®" PWR (+3,3 V)	+ 3,3 V output for Dallas 1-Wire® devices. (max 20mA)

5.2 PORT 1/NMEA

RJ-45 socket		PORT 1	
		Pin Nr.	Description
		1	GPS_IN (Sirf In)
		2	TX_GPS (NMEA)
		3	-
		4	GND
		5	RX
		6	TX
		7	CTS
		8	RTS

This port can be used as system port (to flash firmware and configuration to device) with cable "Port1/2" and as GPS NMEA 0183 output with cable "Port 3".

5.3 Audio port

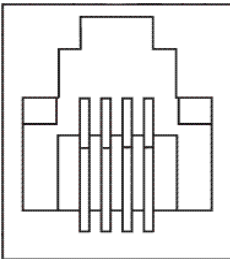
RJ-11 socket		AUDIO PORT	
		Pin Nr.	Description
		1	Mic_Signal
		2	Speaker_Out_2
		3	Speaker_Out_1
4	Mic_GND		

5.4 1-Wire® devices

One of the FM4100 features is realized 1-Wire data protocol, which enables connection of thermometer (DS1820, DS18S20 and DS18B20) and I-Buttons DS1990A reading.

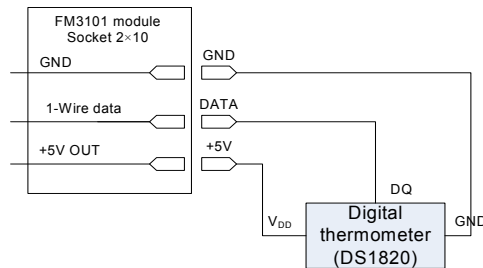

Figure 5. Digital thermometer DS1820 connection scheme

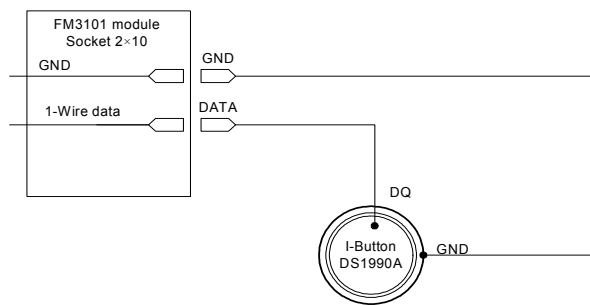

Figure 6. Digital key “I-Button” DS1990A connection scheme

6 ACCESSORIES

JSC Teltonika offers accessories.

6.1 Temperature sensor TTJ-101

To simplify the mounting of the thermometer in the object, it is placed on PCB and inserted into the box. Integrator of the system should solder the FM4100 wires to PCB and place the sensor wherever he wants to measure the temperature.

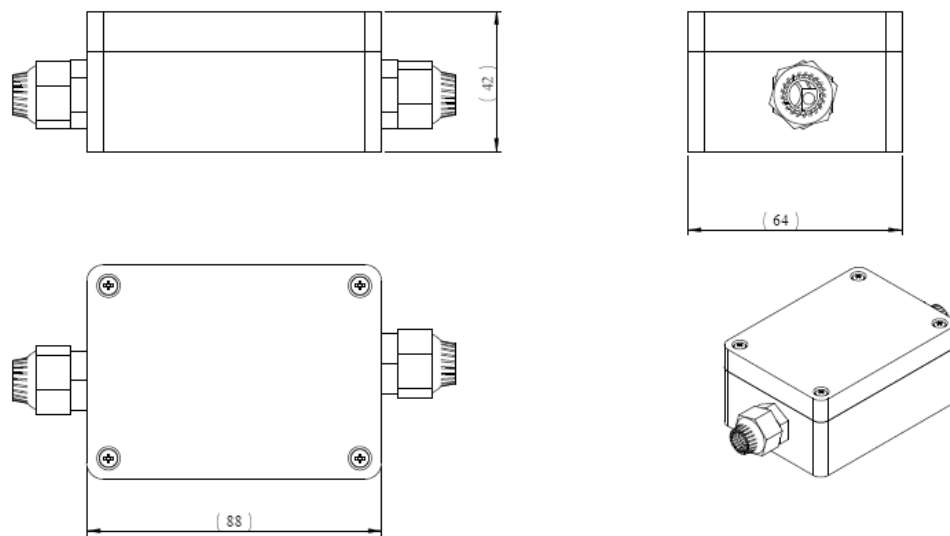

Dimensions in millimeters, tolerance $\pm 1\text{mm}$

Figure 11. TTJ-101 dimensions & spec.

In TTJ-100, Dallas digital thermometer DS1820 is used. It is possible to connect up to five thermometers parallel and measure the temperature in 5 places in the object (see chapter 6.1.1). The picture below describes pinout of the TTJ-100.



Left row of pins

Connected through 100 Ohm to 1 on right row (FM4100 - 20 pin)	1
Data (to 1-Wire® Dallas) (FM4100 - 8 pin)	2
GND (FM4100 - 11 pin)	3
Digital Input	4

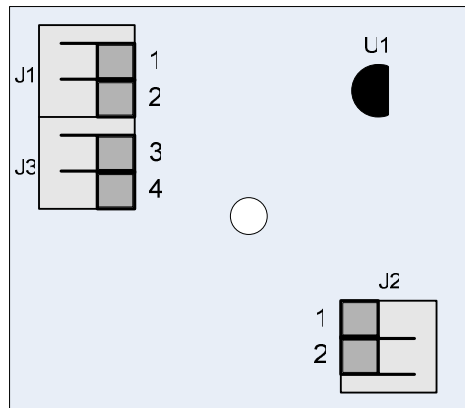

Right row of pins

1	Vpp (+5 Volts DC) – power source for external digital sensor
2	Output from external digital sensor





TECHNICAL SUPPORT

If you encounter any problems when using our products, please contact our technical support by writing an e-mail to support@teltonika.lt . We will be pleased to help you.

If you are interested in other products from Teltonika, please visit our website www.teltonika.com, where you will find our newest products.

If you are interested in product pricing or want to order our products with different antennas, connectors or built-in programs, please contact our sales department by writing an e-mail to sales@teltonika.lt

The supervision of the device is undemanding.

7 CHANGES LOG SHEET

Nr.	Date	New version number	Comments
1	2007 JULY 17	1.1	Chapter 4 updated (LED blinking).
2	2007 OCTOBER 03	1.2	Fixed pinout in chapter 5.1
3	2007 NOVEMBER 05	1.3	Changed 20 th Pin description in chapter 5.1; Fixed pinout in chapter 5.3.
4	2007 DECEMBER 13	1.4	Updated chapter 4, second enclosure drawing added.
5	2008 JANUARY 04	1.5	TTJ pinout table updated