

Marine Grade

Features

- Saltwater tested
- Un-clutched keypad (5200) for heavy duty applications
- Holdback / Free passage option
- 5 Layer marine grade Polish Chrome coating
- 2 Year guarantee
- 316 Stainless steel internal components
- Easily reversible
- 10 Large (10 x 11mm) indented buttons
- Tested to 100,000 cycles
- ISPS approved



5200MG Marine Grade Front



2600 Marine Grade Front



2700 Marine Grade Front



2 Handle Designs Available (5000MG)



Marine Grade Polished Chrome

Borglocks

controlling access

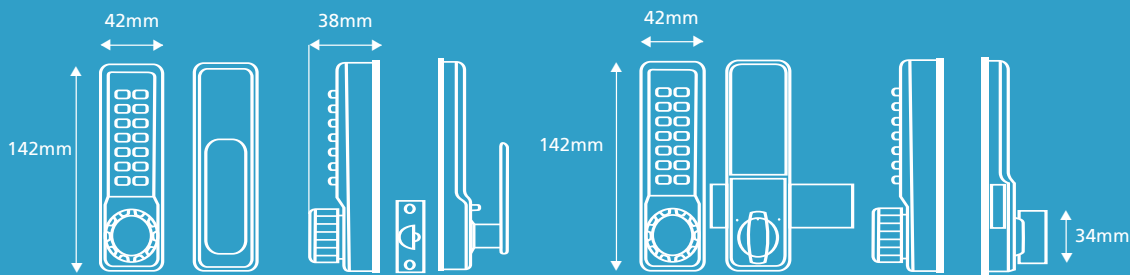

2600 Marine Grade with Holdback

2650 Marine Grade Security Deadbolt

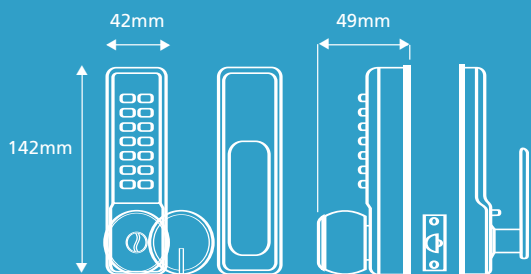

2700 Marine Grade

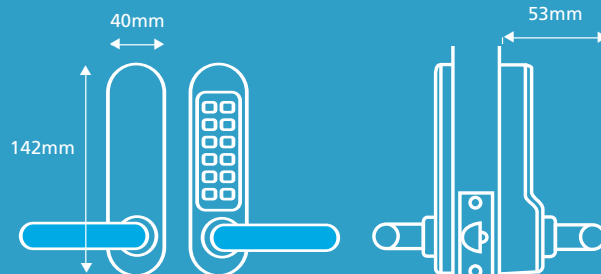

5201MG with 60mm latch



2600MG Marine Grade Back



2650 Marine Grade Back



Waterproof Front Cover



5210 Marine Grade Back

The Marine Series range of products has been developed specifically for marine grade applications and in particular to comply with the requirements of the ISPS code.

Manufactured using marine grade stainless steel all the internal parts have undergone extensive salt water testing and are therefore guaranteed to resist corrosion.

A special 5 layer marine grade polished chrome finish is applied to the outer housing and knob which are guaranteed to resist corrosion for at least 2 years.



+44 (0)1277 210 644

Fax: +44 (0)1277 210 643

www.borglocks.com

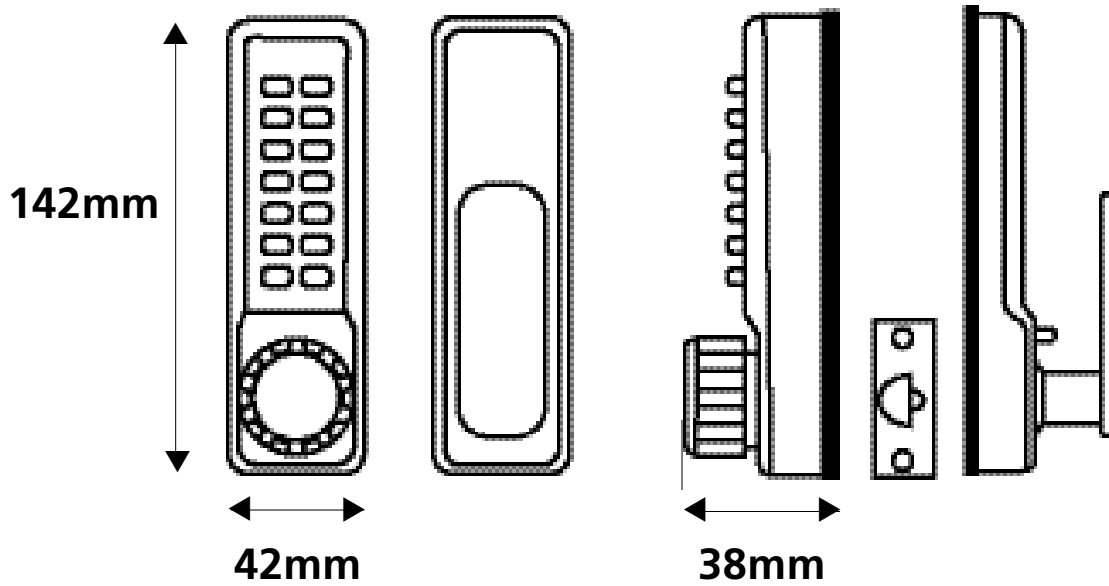

2600 Marine Grade with Holdback

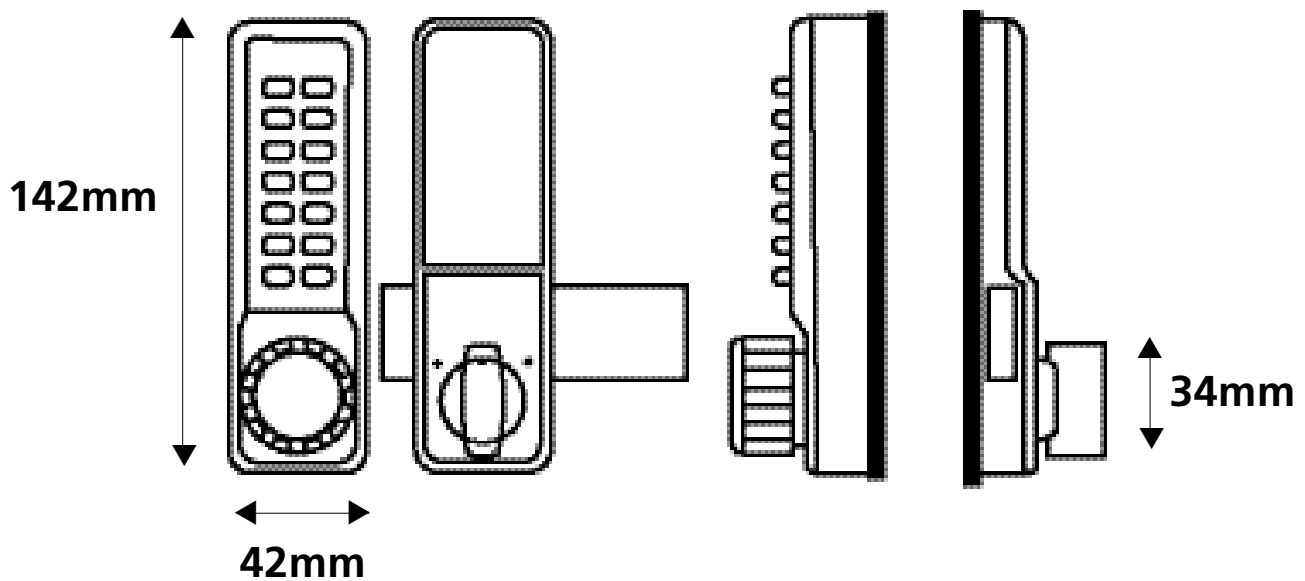

2650 Marine Grade Security Deadbolt

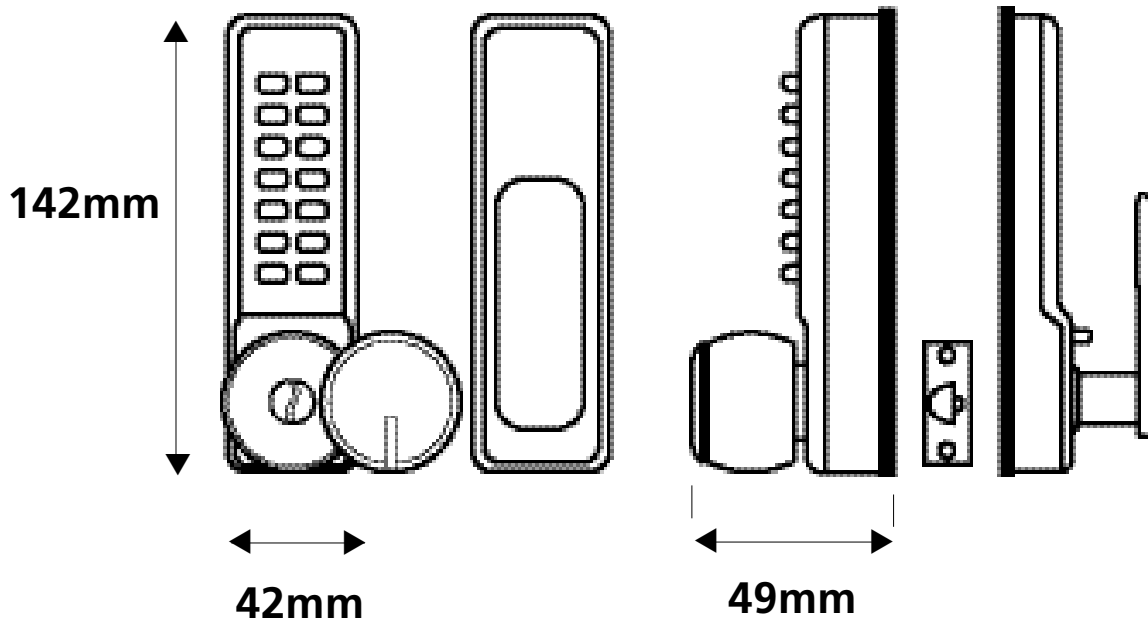

2700 Marine Grade

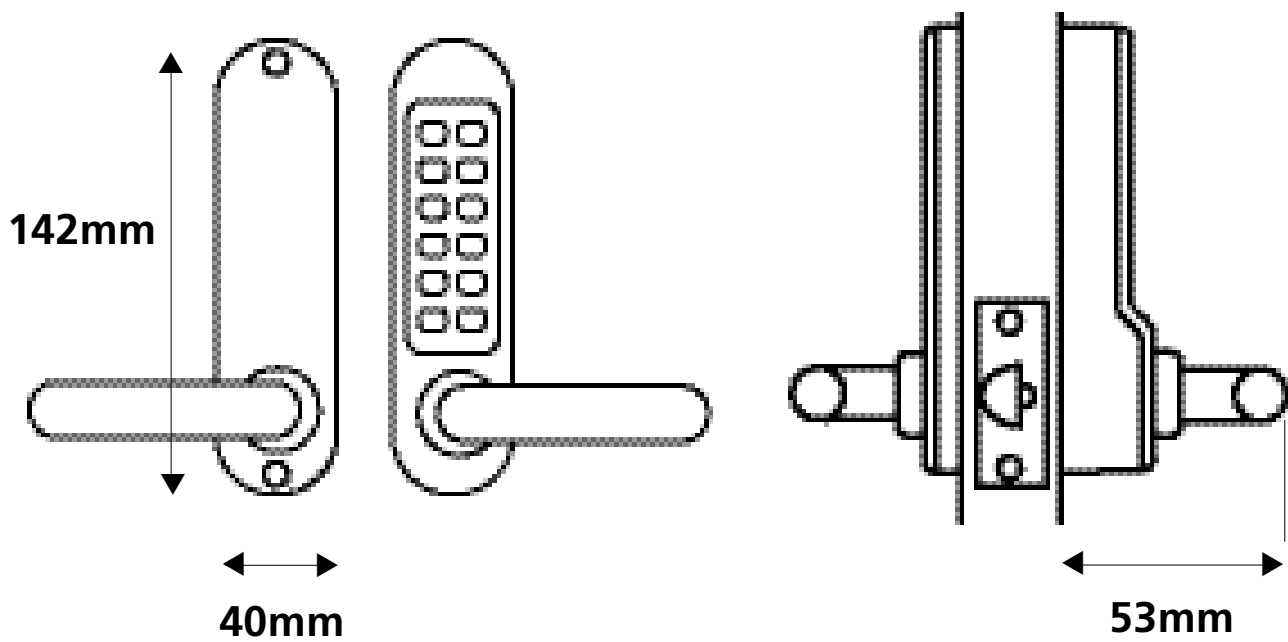

5201MG with 60mm latch