

Dedicated to People Flow™



SMOOTH PEOPLE FLOW® FOR COMMERCIAL ENVIRONMENTS

KONE TravelMaster™ 110

Your trusted escalator partner

With over 100 years of experience and a strong track record in safety, KONE is your trusted partner, dedicated to ensuring smooth and safe People Flow™ in today's commercial environments. KONE escalators and autowalks use our proven, reliable technology designed to meet the wide-ranging needs of commercial buildings worldwide.

The KONE TravelMaster™ 110 escalator is designed for commercial environments, where safety, design and eco-efficiency are key requirements.

3 REASONS TO CHOOSE THE KONE TravelMaster 110

1 Best in class eco-efficiency options that cut the carbon footprint of your building and reduces operational costs

- **The new KONE Direct Drive** is up to 20% more energy efficient than conventional drive solutions
- **The new direct handrail drive** saves energy and extends the lifetime of the handrail, reducing maintenance and operating costs.
- **Smart operational modes and an all new inverter** optimise energy consumption under different load conditions.



The KONE TravelMaster 110

- **Vertical rise:** Up to 13 metres
- **Horizontal steps:** 2 or 3
- **Inclination:** 30°, 35°
- **Step width:** 600 mm, 800 mm, 1,000 mm
- **Radius:** 1.0/1.0, 1.5/1.0
- **Balustrade height:** 1,000 mm, 1,100 mm
- **Speed:** 0.5 m/s, 0.4 m/s with inverter
- **Step chain:** Inside roller chains
- **Operational environment:** Indoor, semi-outdoor, full outdoor
- **Duty cycle:** 12-16 hours/day

2 Peace of mind with the latest safety technology options

- **Fibre-optic skirt monitoring** covers the entire length of the skirt, immediately stopping the escalator when an obstruction is detected between the skirt and steps.
- **New traffic signalisation solutions and audible alarms** provide clear guidance on escalator travel direction.

3 High quality visual design for the best possible user experience

- **Innovative and attractive lighting solutions** that also improve passenger guidance and safety.
- **A wide range of design options** to create stunning visual effects and perfectly match your building's architecture.
- **High quality component finishes** and a harmonised look and feel throughout the KONE product portfolio.

The right escalator for your operational needs

KONE TravelMaster™ 110

The KONE TravelMaster 110 solution is a reliable, efficient escalator package designed for retail, leisure and commercial environments. It includes a worm gear drive combined with the smart star-delta operational mode which automatically regulates the current needed depending on the actual step load.

It complies with all relevant international and local safety codes, and can be enhanced with the latest KONE signalisation and LED lighting options for additional convenience, passenger guidance, and visual appeal.

KONE TravelMaster™ 110 Eco

The KONE TravelMaster 110 Eco further enhances the energy efficiency and durability of the standard TravelMaster™ 110 escalator by utilising the KONE Direct Drive gear, the industry's most efficient escalator drive. In addition, the new direct handrail drive system is more energy efficient and can extend the lifetime of a handrail.

The ecological benefits of the KONE TravelMaster 110 Eco can also be complimented by the use of lubrication-free step chains which ensure that the interior of the escalator is kept free of surplus oil.

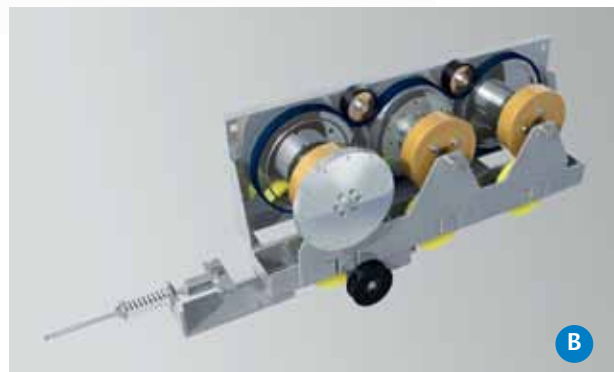
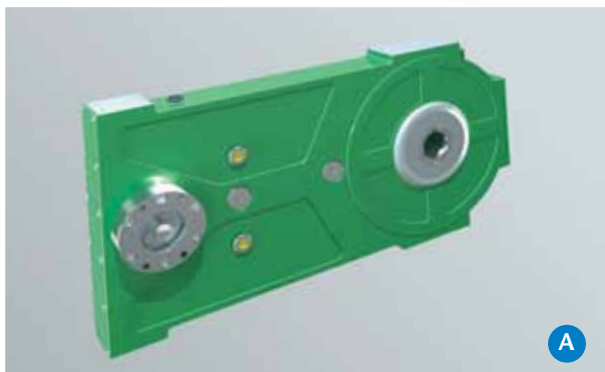
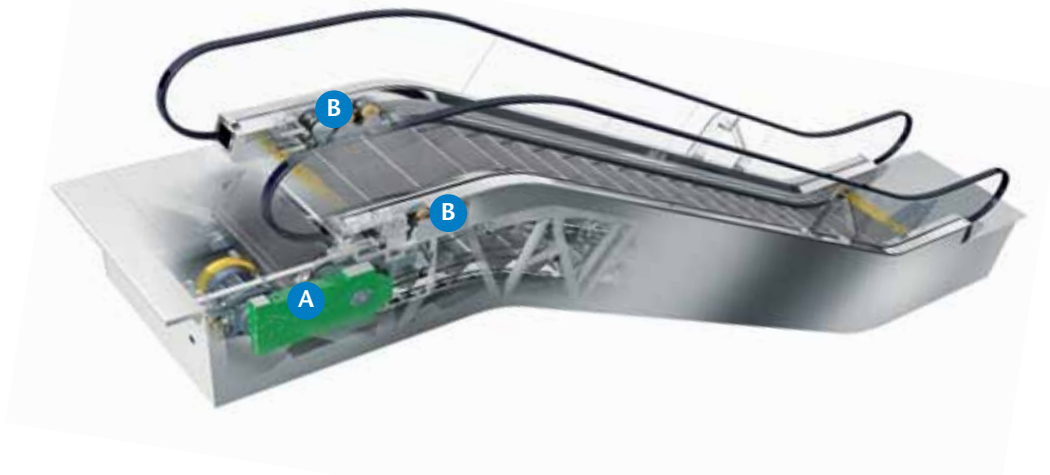



KONE TravelMaster 110	KONE TravelMaster 110 Eco
Worm gear	KONE Direct Drive
Traditional friction wheel handrail drive	Direct handrail Drive
<p>Energy efficiency enhancing options:</p> <ul style="list-style-type: none"> • New energy efficient inverter • Multiple operational modes • Regenerative drive • LED lighting options • Traffic lighting solutions (pole, cube, road sign) • Guidance lighting solutions (comb lighting, step demarcation lighting) 	
<p>Safety enhancing options:</p> <ul style="list-style-type: none"> • Fibre optic skirt monitoring system • Alarm for travel direction • Fall protection barrier 	
<p>Design enhancing options</p> <ul style="list-style-type: none"> • LED continuous lighting or RGB solution for skirt, handrail, side cladding and soffit • LED spot lighting for skirt and soffit (basic and premium) • New premium stainless steel access cover • New KONE designed claddings (etched, honeycomb, coloured glass or laminated) 	

Best-in-class eco-efficiency

THAT CUTS THE CARBON FOOTPRINT OF YOUR BUILDING

At KONE we have always been renowned for our revolutionary eco-efficient technology. The KONE TravelMaster 110™ can be powered by the new KONE Direct Drive – the industry's most energy efficient drive, which is up to 20% more efficient than conventional worm-gear solutions. Installing an eco-efficient KONE escalator solution can also help achieve green building accreditations such as LEED or BREEAM certification.

Power in operation – KONE Direct Drive vs. Worm Gear

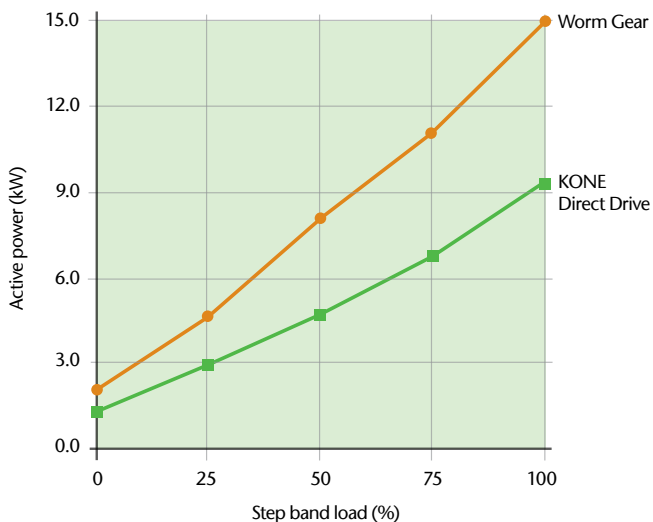

Energy measurements made at a Helsinki Metro station on November 23rd, 2011.



U.S. based business magazine Forbes has ranked KONE the 42nd most innovative company in the world. KONE is also the only elevator and escalator company that has made it to the top 50.

1 A more efficient drive
The KONE-designed Direct Drive helps cut both operating costs and your building's carbon footprint. By replacing the conventional worm gear with the KONE Direct Drive, mechanical losses have been minimised, reducing the drive's energy consumption by up to 20%.

2 Direct handrail drive
With KONE's new direct handrail drive is up to 8% more energy efficient than conventional handrail friction drives and can extend the expected lifetime of the handrail, meaning less maintenance and lower operating costs.

3 All-new energy efficient inverter
The renewed inverter ensures smooth speed regulation during standby operation and minimises energy consumption at full speed.

4 Eco-efficient operational modes
When an escalator is empty, energy consumption is reduced by KONE's smart star-delta operation mode, which regulates the current needed for different types of load situations. In addition, optional eco-efficient operational modes save even more energy by slowing down or stopping the escalator completely when traffic is slow.

5 Long-lasting LED lighting
LED lighting is 80% more efficient than halogen lighting and lasts 10 times longer.

KONE Direct Drive

The new KONE Direct Drive is the eco-efficient heart of the KONE TravelMaster 110™ Eco escalator. As well as delivering best-in-class energy efficiency, this innovative, reliable technology also improves passenger safety and makes maintenance safer and easier than ever before.

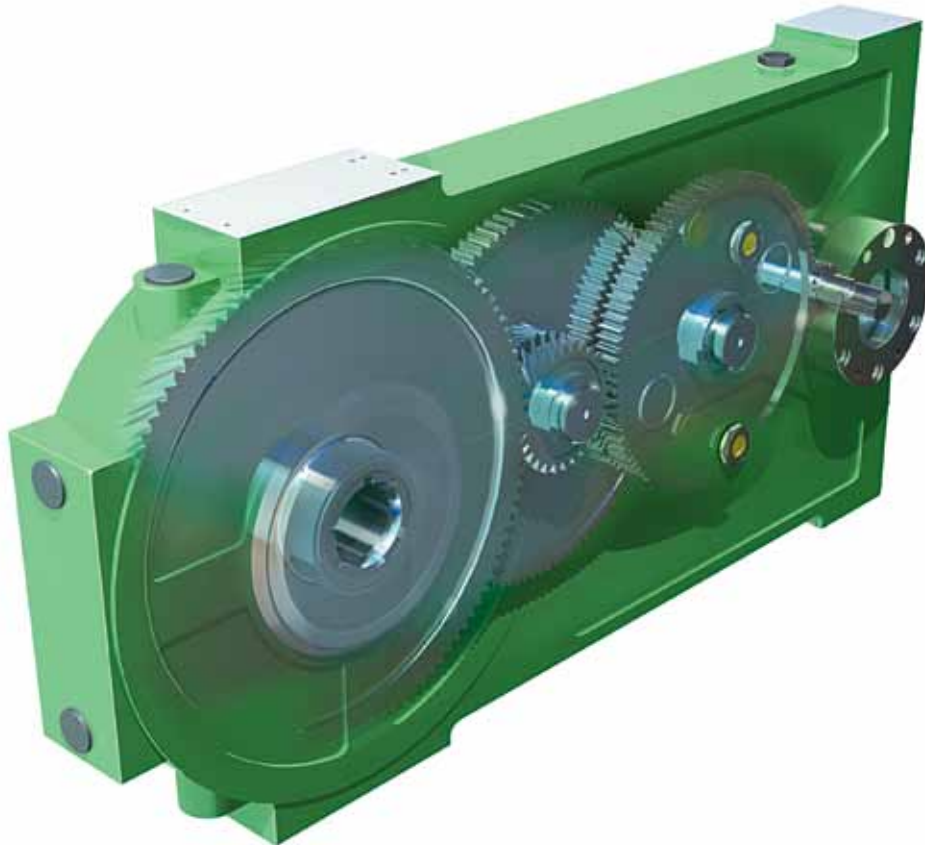

1 Smart, efficient power with reliable performance

- **Eco-efficient design**, with the motor directly connected to the main shaft by the gear, and low input power requirements.
- **Extra power for demanding people flow**, with the possibility to combine two drives to power the escalator step chain.

2 Simple, safe maintenance and longer equipment lifetime

- **Minimised downtime and efficient maintenance** thanks to the drive being located outside the step band, which means easier, faster access for service technicians.
- **Fewer spare parts needed** because of the drive's simple configuration and chainless design.
- **No risk of oil on the step band** due to the external location of the drive, which eliminates the possibility of lubrication oil dripping onto the steps.

3 Increased safety

- **Chainless design** eliminates the risk of chain failure.
- **External drive location** means maintenance is safe and efficient, as there is no need to remove any steps.

Peace of mind

WITH THE LATEST SAFETY TECHNOLOGY

When you choose KONE, you choose peace of mind. Safety is the starting point for every KONE solution. All our escalators are designed to meet and exceed all applicable safety standards, codes, and regulations to ensure the highest levels of safety every step of the way – from planning and installation to maintenance and modernisation. In addition, we offer new and innovative features to ensure that KONE escalators are the benchmark whenever safety is concerned.

The KONE TravelMaster™ 110 has been designed to both maximise safety for passengers and make it easy to inspect the condition of the equipment, ensuring that it operates reliably and safely at all times.

Standards-compliant manufacturing

All KONE manufacturing facilities are ISO 9001 and ISO 14001 certified and meet all relevant escalator industry standards and requirements, for example EN115-1 for the European Union.



COMPREHENSIVE RANGE OF SAFETY OPTIONS



1 Fibre-optic skirt monitoring

This optical detection solution runs along the entire length of the escalator's skirt, immediately stopping the escalator when an obstruction is detected between the skirt and steps. The level of force needed to stop the escalator can be adjusted based on your building's requirements.

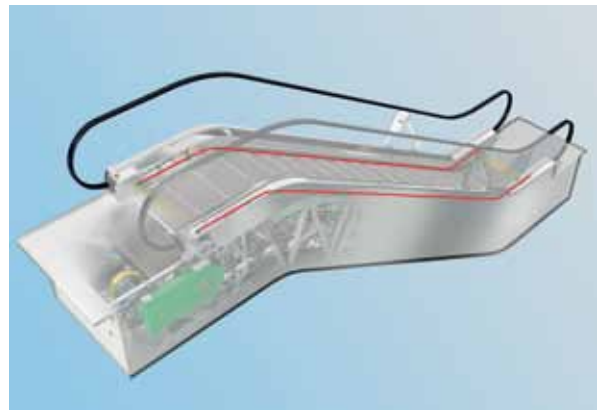

Fibre-optic skirt monitoring

2 KONE Direct Drive

The KONE Direct Drive's chainless design eliminates the risk of chain failure, while the drive is located outside the step band for efficient and safe maintenance, and minimised downtime.

3 Alarm for travel direction

An alarm sounds if passengers enter an escalator in the wrong direction.

4 Visual guidance

Traffic signalisation, skirt lighting, yellow comb segments, and step demarcation provide extra visual guidance for passengers.

5 Fall-prevention features

A fall-protection barrier and extended balustrades provide additional passenger protection.

For a complete list of standard and optional safety features please contact your local KONE sales representative.

High quality visual design

FOR THE BEST POSSIBLE USER EXPERIENCE

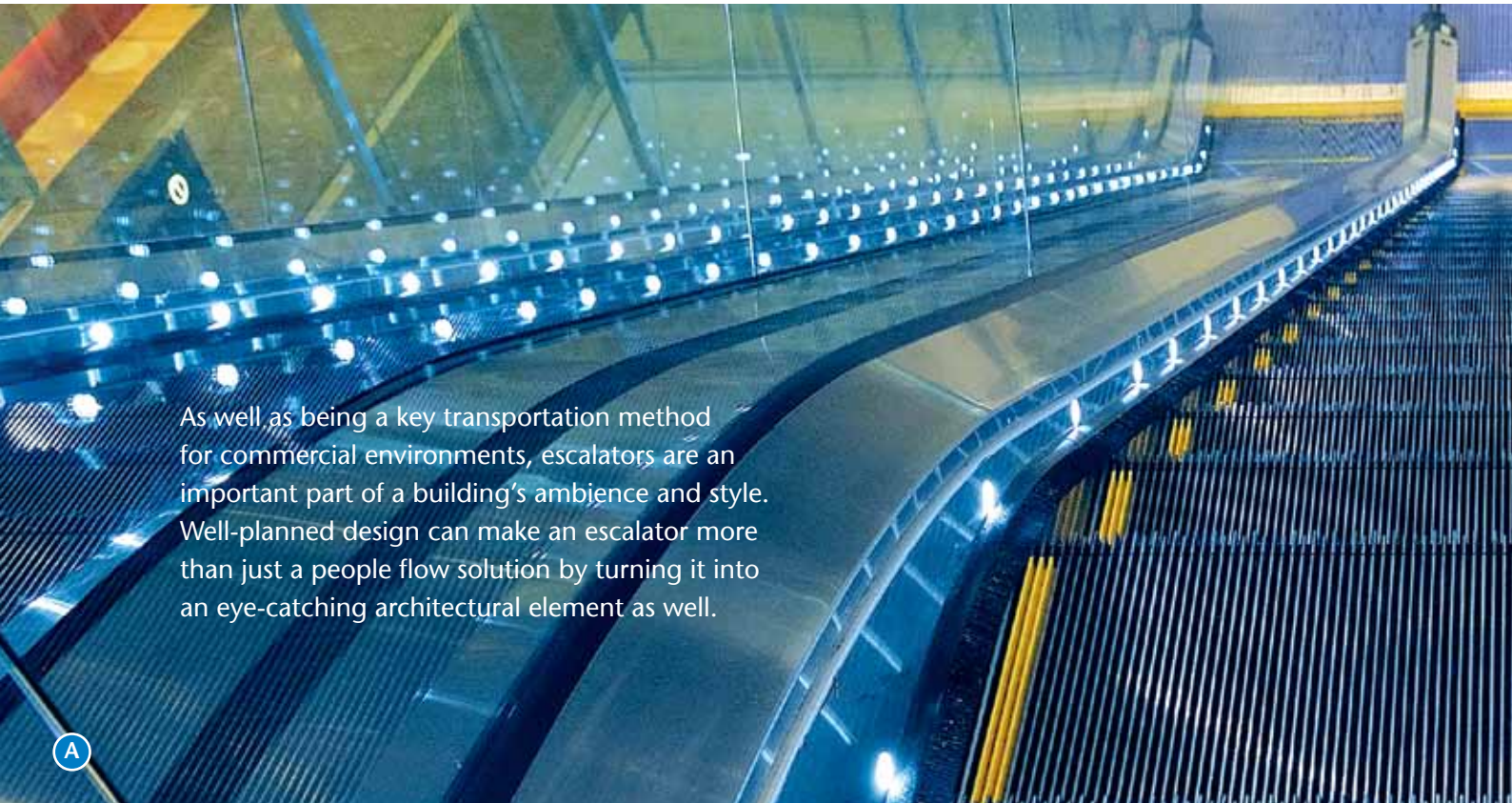

As well as being a key transportation method for commercial environments, escalators are an important part of a building's ambience and style. Well-planned design can make an escalator more than just a people flow solution by turning it into an eye-catching architectural element as well.

A

1 Innovative and attractive lighting solutions

KONE's new cladding, lighting solutions and traffic lights provide the final touch to your escalator's visual design. Our traffic-light options – cube, road sign, and traffic pole – provide a simple, stylish approach to safety and passenger guidance.

2 A wide range of design options

KONE's design offering consists of a wide range of innovative materials and features. The combination of unique textured and patterned cladding materials with novel lighting solutions creates a stunning visual effect.

3 Attention to detail and excellent finishing quality

All of our escalator components are designed with great attention to detail. KONE escalators are equipped with attractive front plates, guards, and access covers – all with high quality finishing. The design of KONE products is harmonised throughout our portfolio for a consistent look and feel in your building.

4 Tailor-made possibilities

KONE's renowned engineering and design capabilities are always available to help you realise your architectural vision with customised specifications for your premises.

New attractive lighting and guidance solutions that improve the safety of your escalator: ▶

- A. LED skirt spot lighting
- B. Traffic light cube
- C. Traffic light road sign
- D. LED under handrail lighting



Supporting you every step of the way

Choose a partner with over a century of experience in delivering pioneering escalator solutions. Get expert advice from professionals and enjoy the peace of mind that comes with comprehensive support. KONE is with you every step of the way – from planning and design, through installation and maintenance, to modernisation – for the entire life cycle of your building.

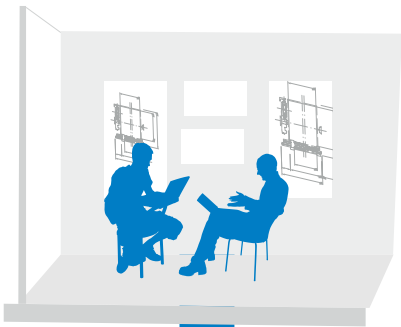

1 Expert design and planning services

- Expert planning advice helps you specify the optimal solution for your building.
- Easy-to-use online design tools save you time and effort during the design process by allowing you to create CAD drawings and 3D BIM models.
- Energy consumption calculations available for every individual escalator solution.



2 Safe and efficient installation

- Highly efficient installation methods result in considerable cost savings for our customers and minimise disruption to other construction work.
- Strict quality criteria for each phase of installation ensure that it's right the first time, every time.
- Continuous training, site audits, safety passports, and proven methods ensure maximum site safety.



3 Quality assurance at handover and professional maintenance

- KONE's own reliability laboratory tests and approves every component used in our escalator solutions.
- Our global spares center stocks over 150,000 parts and offers 24-hour delivery for the most commonly requested parts.
- Preventive KONE Care® maintenance solutions make it easier to monitor and budget for escalator maintenance.

KONE Escalator Toolbox – including BIM models

- With the **KONE Escalator Toolbox** you can create a detailed equipment specification online and customised CAD drawings for preliminary planning.
- **KONE Building Information Modeling (BIM)** models make it easier and quicker for architects to prepare digital escalator designs. Included in the Escalator Toolbox, these models are compatible with most common project documentation systems and include the latest KONE escalator specifications. Once your design is ready, you can send the specifications directly to a KONE sales representative for tendering and/or ordering.

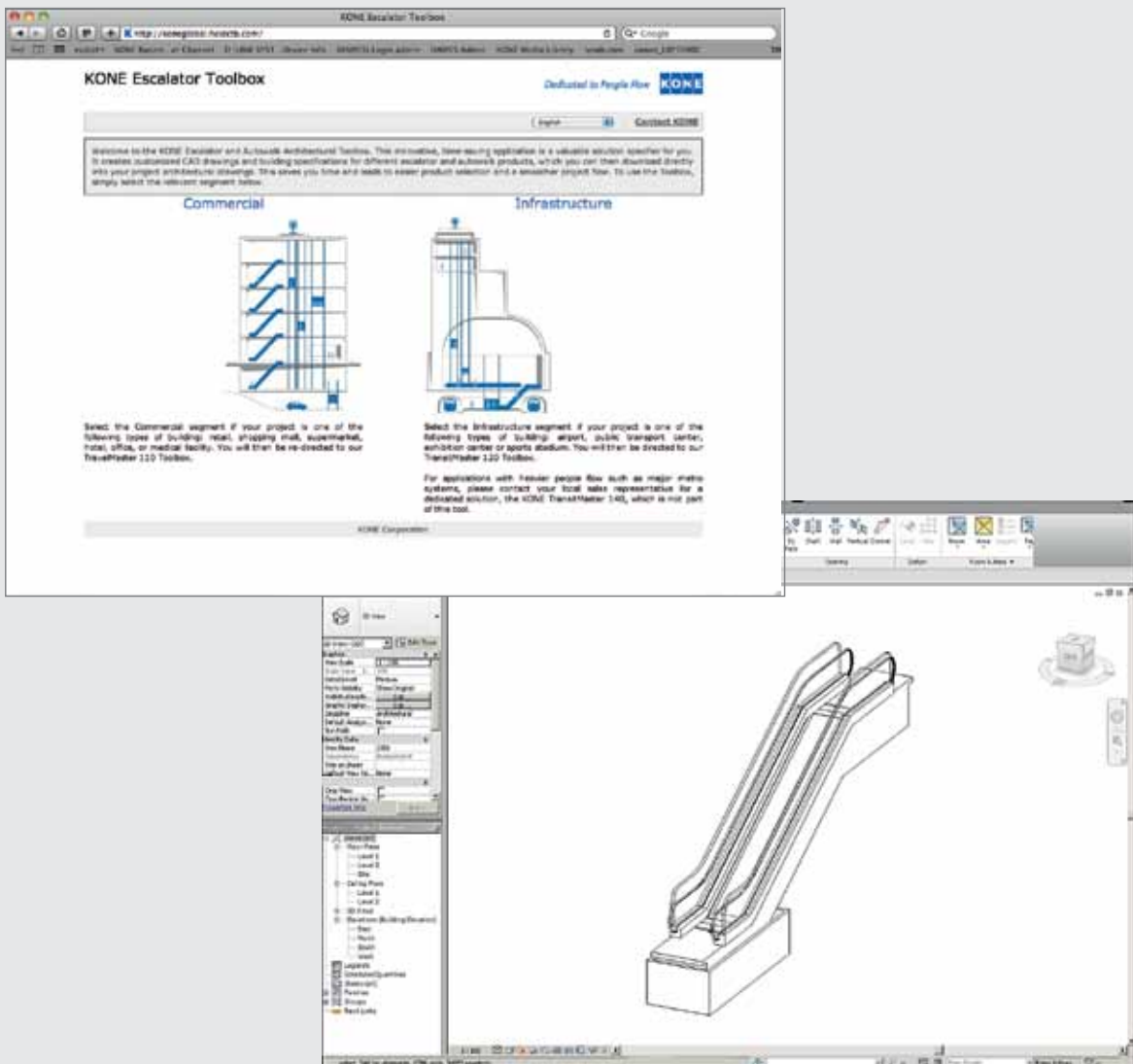

The KONE Escalator Toolbox is available online at <http://koneglobal.hostctb.com/>

Visual design and customisati

KONE escalators combine industry-leading eco-efficiency and the latest safety technology with a wide range of high quality design options – all supported by our unrivalled engineering and people flow expertise. Our sales teams provide expert advice that will help you choose exactly the right solution for your building. With our latest range of design options, you can create an escalator that is both an essential means of transportation and an eye-catching architectural element.

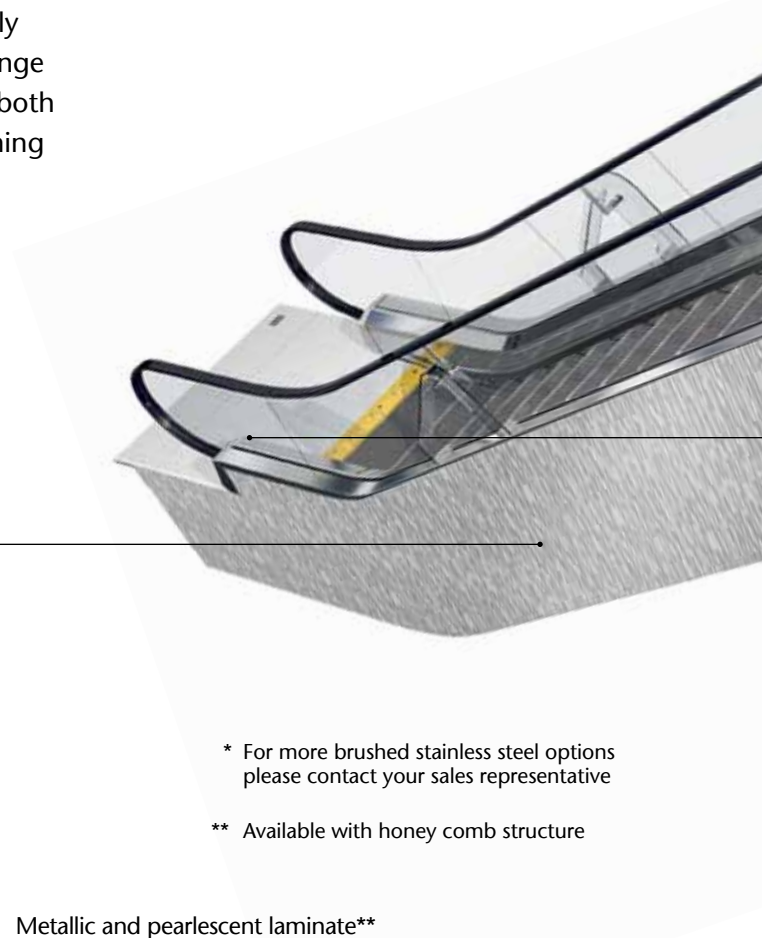

Claddings

Brushed stainless steel



ST4*
Silver

* For more brushed stainless steel options please contact your sales representative

** Available with honey comb structure

Colored laminate**



LH001
Dotted White



LH002
Dotted Black



LH003
Navy Blue

Metallic and pearlescent laminate**



LH004
Pearl Steel

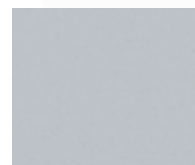

LH005
Pearl Silver



LH006
Bronze Mesh

Colored glass



G104
Bronze

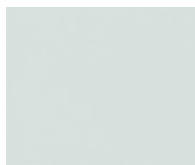

G105
Bright White



G107
Black Pearl

Etched stainless steel**



ST31S
Silver High-Rise



ST41S
Silver Bamboo

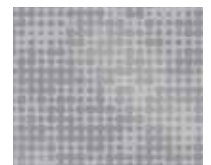

ST42S
Silver Cloud

on capabilities



Traffic light signalisations

Access covers



Traffic light cube



Traffic light road sign



Stainless steel surface with punched diamond pattern (available in 304# and 443#)

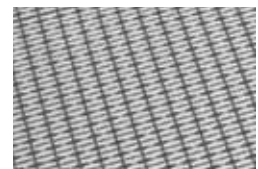

Black painted Stainless steel surface with punched diamond pattern (available in 304# and 443#). Floor numbering is available.

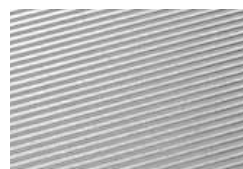

Natural ribbed aluminium

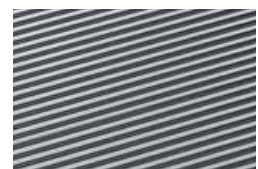

Ribbed aluminium with black grooves



Stainless steel surface
New KONE Design access cover



KONE provides innovative and eco-efficient solutions for elevators, escalators and automatic building doors. We support our customers every step of the way; from design, manufacturing and installation to maintenance and modernisation. KONE is a global leader in helping our customers manage the smooth flow of people and goods throughout their buildings.

Our commitment to customers is present in all KONE solutions. This makes us a reliable partner throughout the life cycle of the building. We challenge the conventional wisdom of the industry. We are fast, flexible, and we have a well-deserved reputation as a technology leader, with such innovations as KONE MonoSpace® KONE MaxiSpace™, and KONE InnoTrack™. You can experience these innovations in architectural landmarks such as Capital City in Moscow, Hongqiao Transport Hub in Shanghai, North LaSalle in Chicago and Tour First in Paris.

KONE employs on average 35,000 dedicated experts to serve you globally and locally in over 50 countries.

KONE plc

Head Office

KONE plc, Global House, Station Place,
Chertsey, Surrey, KT16 9HW
sales.marketinguk@kone.com

Regional Offices

KONE plc, Unit 5 Beechwood ,
Chineham Business Park, Basingstoke,
Hampshire, RG24 8WA

KONE plc, 2425 Regents Court,
The Crescent, Birmingham Business Park,
Solihull, B37 7YE

KONE plc, Suite G7/G4, Duart House,
Finch Way, Strathclyde Business Park,
Bellshill, ML4 3PR

KONE plc, Worth Bridge Road, Keighley,
West Yorkshire, BD21 4YA

KONE plc, 34 Bedford Road,
Clapham, London, SW4 7HJ

KONE plc, Block C Millennium Business
Park, 922 Birchwood Boulevard,
Birchwood, Warrington,
Cheshire, WA3 7QN

General Enquiries

Tel: 0845 1 999 999

www.kone.co.uk

