

## Simple Product Safeguards

The Packsolo system converts rolls of 100% recycled single-ply paper into strong, but supple paper cushions to protect your products in transit.

There are various paper options available, so you can choose the perfect grade to meet the specific requirements of your operation and products.

Paper cushions are a clean and simple, eco-friendly alternative to traditional void fill methods. Paper rolls for the Packsolo system convert at high speed, to up to 80 times their original volume.



The Packsolo system has the option of being pre-set to operate in either fully automatic or semi-automatic mode; alternatively it can be controlled by a simple footswitch.

The main advantage of cushion packs over alternative void fill solutions and paper dispensers is that total void fill is not necessary, thus **reducing the 'in-the-box' cost**. It is also favoured by many recipients as it is clean and easy to re-use or dispose of responsibly.



## Friend to the Environment

- Not one single new tree is cut down to produce Easypack's paper packaging, as all paper used by our systems is 100% recycled, 100% recyclable and 100% biodegradable
- The strength and versatility of the paper cushions mean that total void fill is not necessary
- Airspace can be left within the box, thus reducing the amount of material needed
- Packaging is produced as needed, reducing waste, bulk transport costs and storage space
- Strong paper means that the size of boxes can be reduced and less void fill is required
- Paper is PH neutral and completely free of oil based products



## Select Your Solution

The Packsolo system is offered in a range of configurations, each designed to best suit your needs. It can be swiftly installed on a standard frame, or if you have more complex requirements, our design team can work closely with you to integrate the system into new or existing packaging stations.



The new digital control panel

## Easy and Efficient

The Packsolo includes a brand new digital control panel, which is now easier than ever to use. It allows the user to pre-select exact pack lengths and quantities, which can easily be over-written with the use of the standard foot switch, without the settings being lost. The panel can also be remotely located to suit the individual needs of your packing stations.

The Packsolo's range of paper options combined with adaptable controls mean that the system provides total flexibility to meet your packaging needs.

The system is designed to be economical and easy to use; one of its many features include Easypack's unique easy loading system, saving you precious time and effort changing the paper rolls, thus allowing you to maintain an incredibly efficient packing process.

## 30 Second Paper Loading



Place the roll of paper on the holder



Feed the paper through the rollers

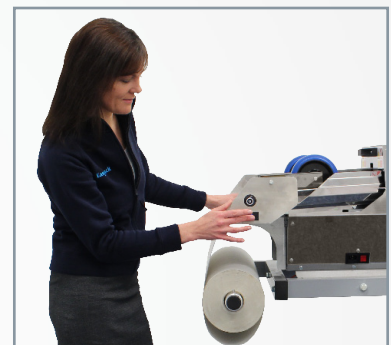

Press the blue 'auto-load' button

## TECHNICAL INFORMATION

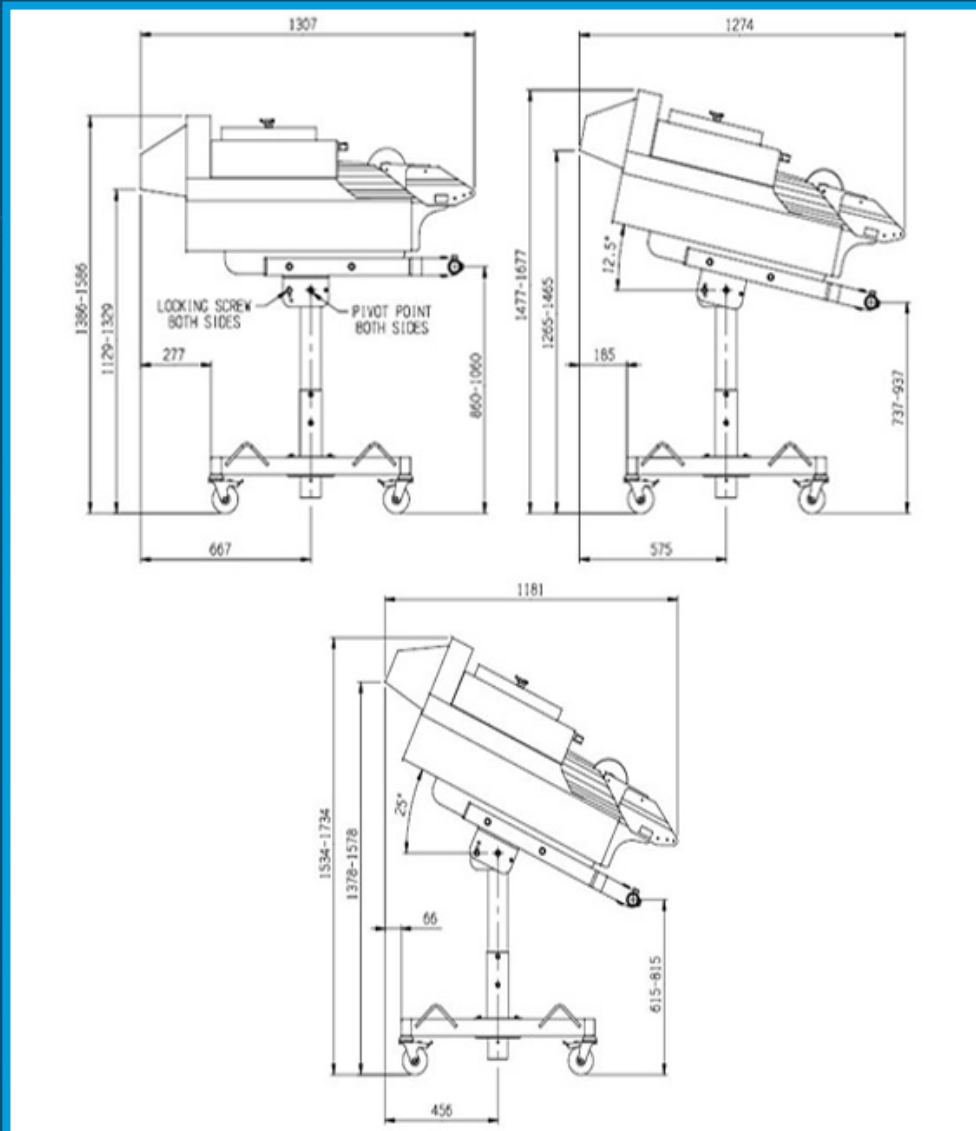

## SPECIFICATIONS

Pallet Quantity	20 Rolls
Machine Weight (standard with frame)	147 kg (approx.)
Roll Weight	15 kg (average)
Roll Length	up to 300m
Cushion Width	180 mm
Output Volume	up to 2.5m <sup>3</sup>
Output Speed	32m per min
Ideal Usage	On demand
Voltage	230V
Max Power Input	920W

Easypack Ltd

Unit 1 | The io Centre | Arlington Business Park | Stevenage | Hertfordshire  
SG1 2BD | United Kingdom