



Simple Protection

The pioneering Spiral Pro uses Easypack patented technology to deliver high volumes of void fill paper packaging in seconds! The flexible tubes of 100% recycled paper are produced on demand, straight into the box, so you need never use more than is necessary.

The new & improved Spiral Pro has been designed to be extremely simple to use to allow packers to focus on the task at hand and despatch as many boxes as possible.

The Spiral Pro is ideal for a wide range of industries and its small footprint and non-intrusive design mean that it is ideal for all setups from placing a single unit into a basic packaging setup, to multiple dispensers in larger distribution facilities.



The Spiral Pro is compact enough to fit into any packaging operation and is suitable for a wide range of industries.

The Spiral Pro is a proven protective void fill solution, with the added benefits of being environmentally friendly, efficient and cost effective.

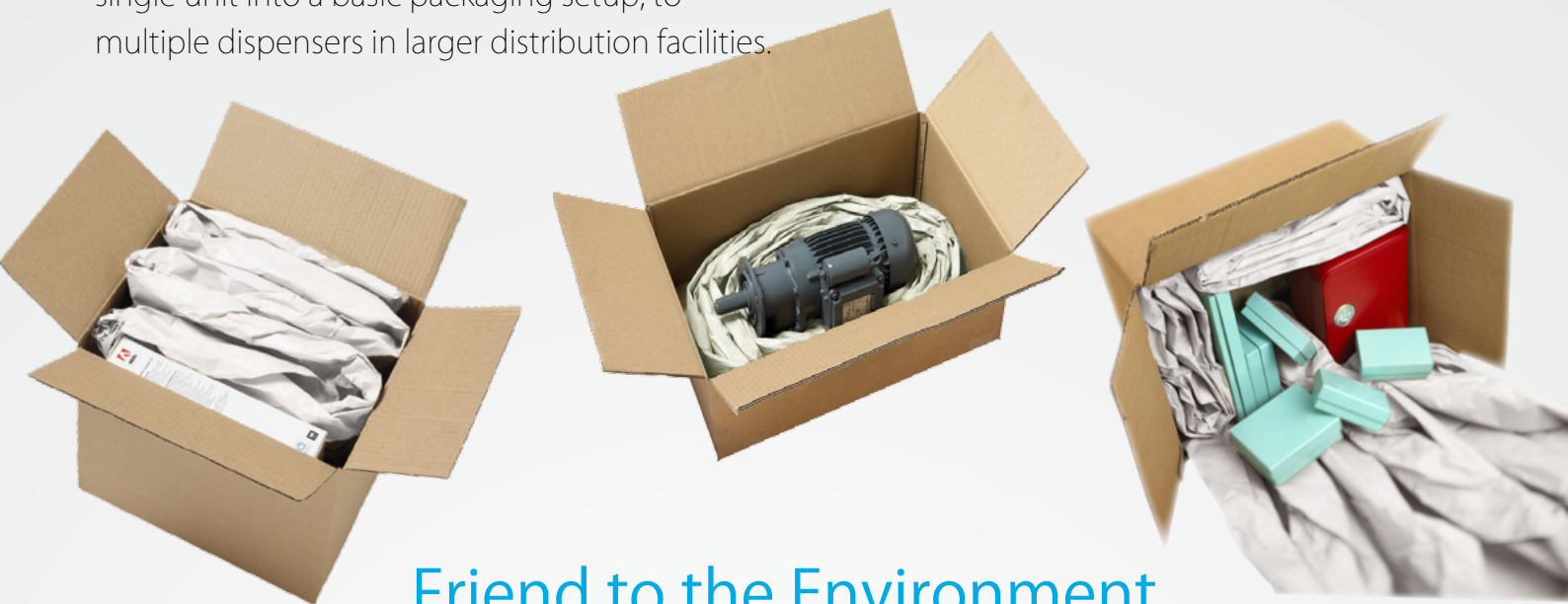

Friend to the Environment

- Not one single new tree is cut down to produce Easypack's paper packaging, as all paper used by our systems is 100% recycled, 100% recyclable and 100% biodegradable
- The strength and versatility of the paper cushions mean that total void fill is not necessary
- Airspace can be left within the box, thus reducing the amount of material needed
- Packaging is produced as needed, reducing waste, bulk transport costs and storage space
- Strong paper means that the size of boxes can be reduced and less void fill is required
- Paper is PH neutral and completely free of oil based products



Unpack & Go

The new Spiral Pro is lightweight and easy to install. It is available with either a bench mount or a floor stand. Assembled with minimal effort, the unit can simply be clamped onto the side of most packaging benches or wheeled out onto your packaging area for immediate use.

The slim, upright design of the Spiral Pro mean that it will merge into your current packaging setup without reducing your working space.

The versatile paper can be used to fill voids in boxes for light items and for heavier items it can be coiled or scrunched to provide added cushioning and protection to virtually eliminate the risk of products



The Spiral Pro takes up minimal space on packing benches and has an adjustable height .

Safe & efficient

The Spiral Pro is motor driven so it is speedy and efficient. It has been designed to the highest safety standards by our team of in-house engineers to ensure your employees are being offered the very best equipment to meet the needs of their role.

The new Spiral Pro offers a unique cable management system that will eliminate problematic tangling of wires which - as well as being unsightly - can also pose a safety risk.

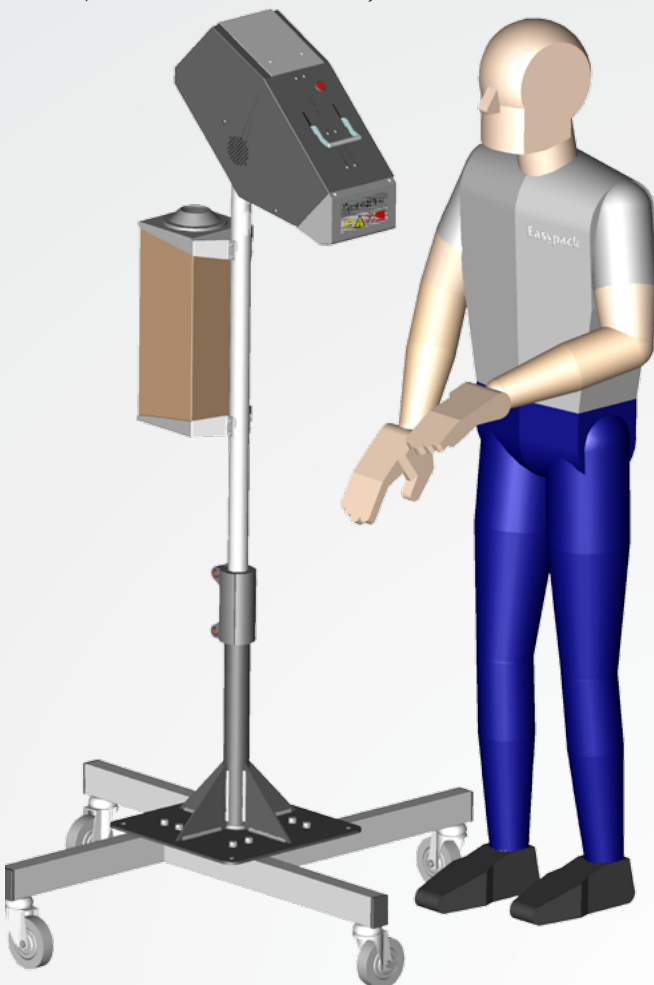

The Spiral Pro was designed and built with the customer's needs in mind.



Each roll produces up to 0.8 cubic metres of paper cushioning

TECHNICAL INFORMATION

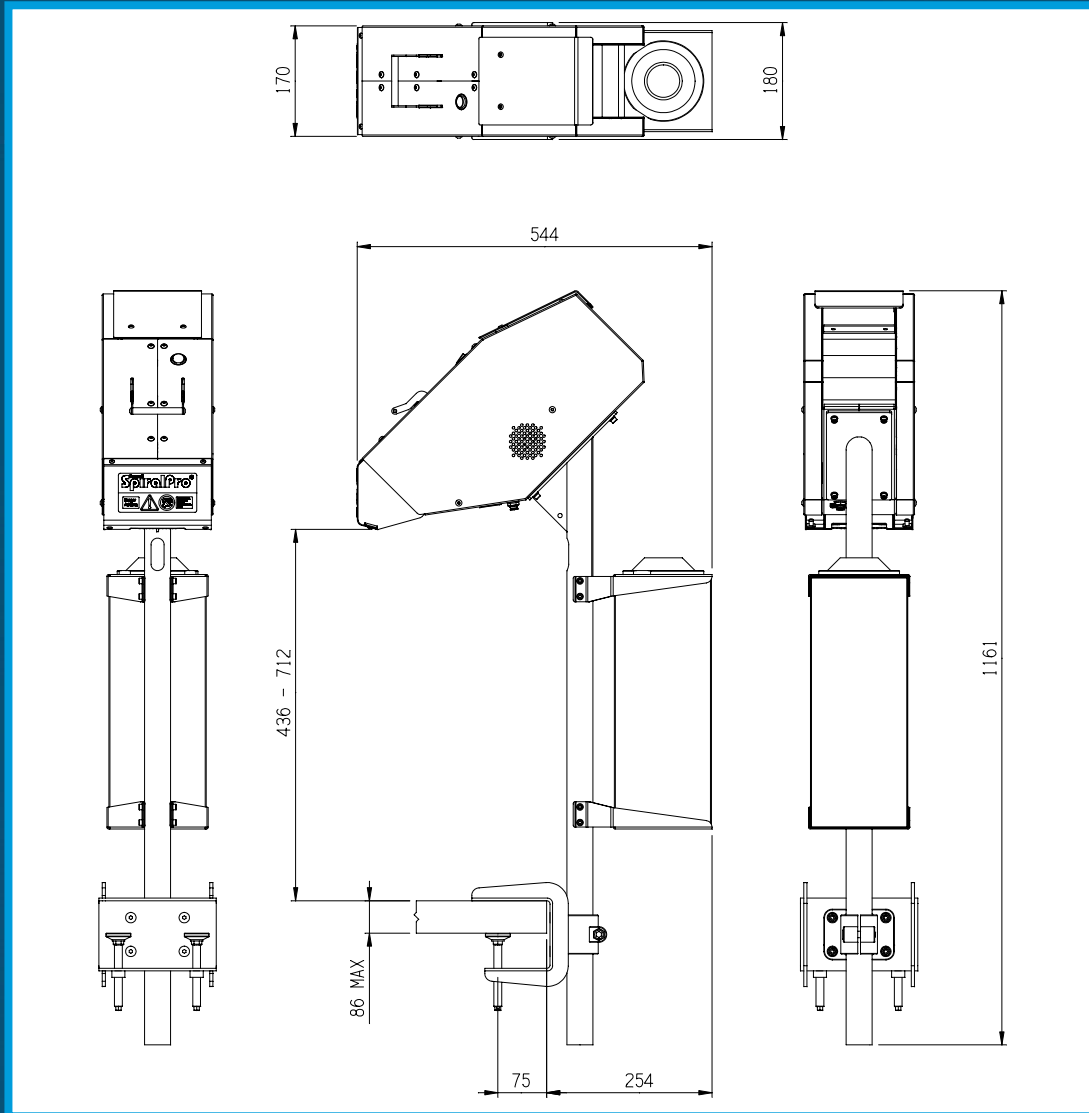

SPECIFICATIONS

MACHINE

Paper refill box quantity
Machine weight (w/o bench clamp)
Roll weight
Output volume (per roll)
Spiral output tube diameter (nominal)
Standard feed rate (per minute)
Ideal usage
Voltage
Max power input

SPIRAL PRO

6 rolls
10.73 Kg
4.17 Kg
up to 0.8 m³
50 mm
88.5 m
Continuous
220V / 240V
230W

Easypack Ltd

Unit 1 | The io Centre | Arlington Business Park | Stevenage | Hertfordshire
SG1 2BD | United Kingdom