

1100 Auto Fill Pass-Thru Individual Flaps

EQVI1100PTWIF



- Automatic filling and draining water reservoir
- Built in Wrap Storage
- Rear pan supports higher for increased visual display
- Thermostatically controlled environment
- Illuminated interior

1100 AUTO FILL PASS-THRU SPECIFICATION PAGE

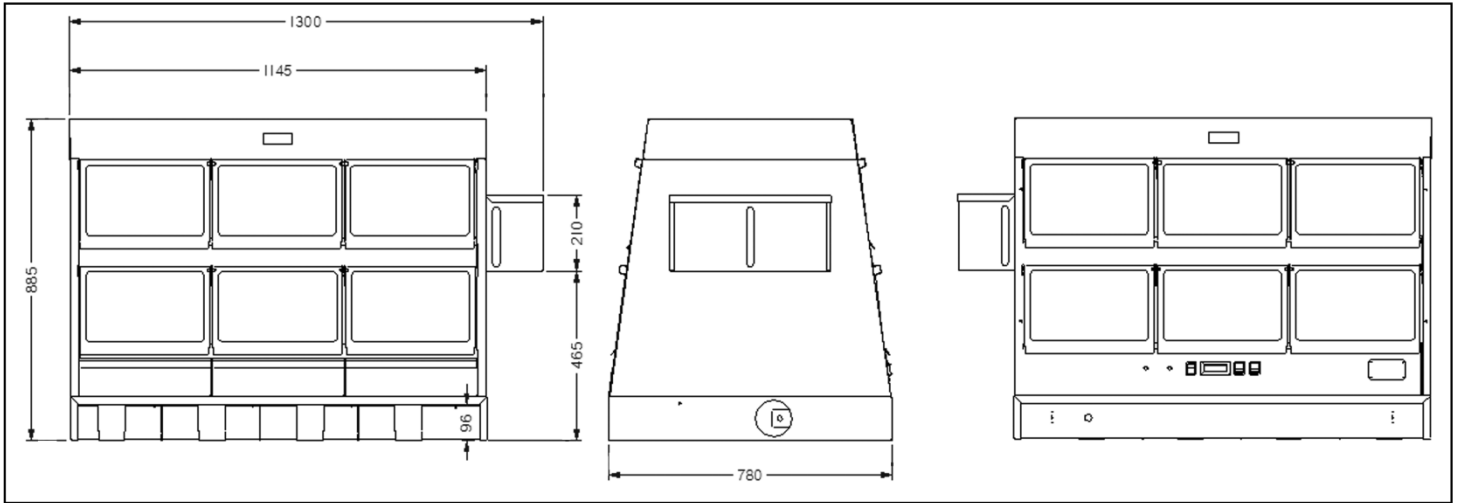

MODEL EQVI1100PTWIF

Dimensions	Machine
Height	885mm
Width	780mm
Depth	1305mm
Weight	93kg
Electrical	1 phase, 50HZ AC, 230v
Running Amps	9.2 Amps
Connection Type	BSCHUKO 2/3 PIN PLUG
International Option	N/A

All **Vizu AutoFill Pass-Thrus** have been tested and checked for proper operation before leaving the factory.

Upon delivery please check the unit for damage. If the unit is damaged, contact the carrier, or Fast Food Systems, immediately and file a damage claim (found in the back of the manual) Please retain all packing materials.

Damage must be reported within 7 days of delivery

General Description

The unit has been designed to hold cooked foods in a humid atmosphere. Being a pass-thru unit the machine can be loaded from one side and unloaded from the other.

Assembly and Installation Instructions

1. Unpack machine from packaging
2. Peel all surfaces of plastic film and wipe down with warm soapy water
3. Position machine on a level surface
4. Machine must be affixed to a fresh mains water supply, or side mounted bottle filled daily with fresh water
5. Machine must be plugged into a 13Amp power supply
6. Position perforated support channels across internal aperture, space to suit.
7. Place gastronome pans and wires into their positions between support channels.

Switch Controls

- Red Switch – ‘ON/OFF’
 - Controls the temperature within the cabinet
- Green Switch - ‘LIGHTS’
 - Operates the lights within the unit – Can work independently of the heat switch as a display feature
- Green Switch – ‘HUMIDITY’
 - Controls humidity in the cabinet, in the ‘Off’ position the cabinet becomes a heated dry cabinet

Instructions for use

1. Ensure Mains power is on – The green 'POWER' light should be lit
2. Ensure either Mains water is on, or bottle is filled
3. Turn red 'ON/OFF' switch to 'ON'
4. Turn green 'HUMIDITY' switch to 'ON'
5. Leave the machine for 20 minutes to heat and humidify
6. Turn on 'LIGHTS' as required

LED Indication

- When the heater is on, it is lit green.
- When the heater is off (and water off), it is unlit.
- When the water valve is open (water filling), it is lit red.
- If the water valve has been open for over 10 seconds and the water level is still measuring low (indicating water tank is empty), it flashes red rapidly –and stays like this until the water level is measuring normal again. Refill the side mounted Bottle, or check the mains supply, then check Fault Finding if issue still remains

Description of Auto Fill Pass Thru machines

The Auto Fill Pass Thru unit must only be used to keep cooked food hot and moist; it must not be used to re-heat cooked foods.

The machine is suitable for holding cooked meats and fish.

This unit is more complex machine than a standard Pass-Thru and as such there are a few more rules of use.

1. When the machine is placed in the position that it will be used in it is important to ensure that it is level. Ensure that the surface the Pass-Thru is mounted on is flat and well supported.
2. The machine can be either connected to a Mains water supply or a remote water tank, which must be refilled by the machine operator.
3. The unit is supplied as standard with the remote water tank connected to the right hand side of the unit. The water pressure reducing valve is in the fully open position (gravity feed position) and the unit will fill at the appropriate rate.
4. If the water tank is to be left in the factory position then no further action is necessary.
5. If the tank is to be re-positioned, OR mains feed is to be made the water feed connection to the machine must be dis-connected. See Fig. 1 & Fig. 2 below.

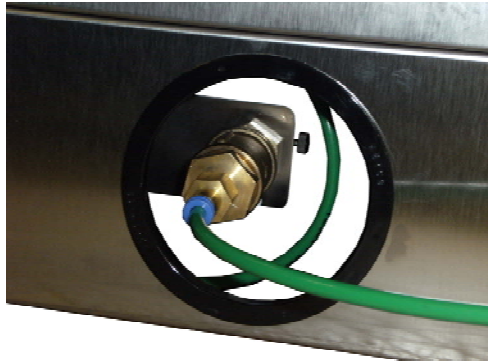

Figure 1



Figure 2

6. The tank can be mounted on the opposite side of the unit if desired, alternatively the tank can be placed on an up-stand or other location – if this is the case it is important that the tank is NOT at a lower position than it would be if it were mounted on the side of the machine, otherwise the water flow will be adversely affected.
7. To move the valve locate the bracket and undo the securing screws, moving the bracket to the opposite side of the unit see Fig. 3 & Fig. 4



Figure 3

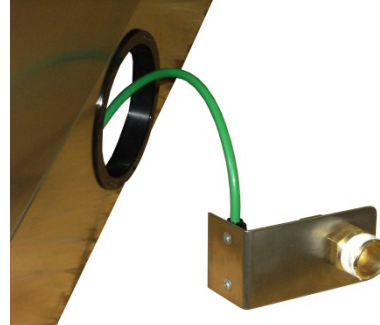

Figure 4

8. To connect the mains supply, simply screw the mains inlet pipe into the thread on the bracket, as shown in Fig. 5. Ensure a tight waterproof seal - use PTFE tape.



Figure 5

9. When installing the machine to a mains water supply the pressure regulating valve within the machine must be adjusted to reduce the pressure. This is done by winding the thumb screw in until the desired pressure is achieved, see Fig. 6.

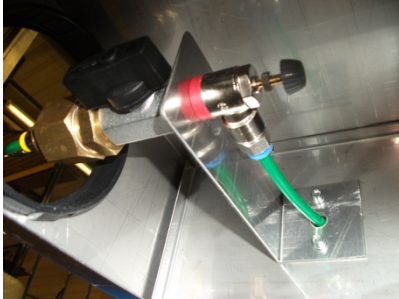

Figure 6

10. Ensure that the water tray is pushed in to the unit fully (it should lock in position – pull gently to check). The water filling sequence can now begin. Switch the 'ON/OFF' switch for 'HUMIDITY' to the 'ON' position. The float of the machine will sense that the water tray is empty and it will begin to fill the machine. (If this does not happen please check that the draw is fully pushed in (activating the micro-switch) and that the water supply is connected and able to flow). The amber light on the panel will light during filling stage, (this is a slow process). The correct pressure should see the water flow in to the water tray without causing splashing - see below.



Figure 7

11. It is important that the machine fills slowly so that the water can be heated by the under pan heater, allowing the machine to fill too quickly will cause the temperature to drop.

The machine is factory set to 70°C. This is adequate to hold cooked food at a safe and legal temperature (i.e. above 63°C)

Use of Auto Fill Pass-Thru machines

1. Switch the machine on (red switch), then switch the auto-fill and lights on (green switches).



2. The machine should be left for 20 minutes to allow it to reach the correct operating temperature. By having an automatically filling water system the internal atmosphere of the unit will be humid, improving the “hold time” that products can be kept for.
3. Whenever the flaps are raised on the Pass Thru unit they should also be lowered in a controlled manner and not allowed to drop and bang against the side of the machine. Allowing the flaps to hit the machine can result in damage to the doors but more importantly weaken the bulbs and reduce their life.
4. Ensure that the water supply is maintained – otherwise the machines humidity will be affected.

Cleaning of Auto Fill Pass-Thru machines

1. The water tray should be removed daily for cleaning.

TAKE CARE WHEN REMOVING THE WATER TRAY

Gently lift the front of the water tray and then slide tray out of machine, the water will cut-off automatically when the tray is removed. Next drain water in to a sink. The water pan can be removed from the tray by carefully lifting the float and then removing the pan. Be careful not to damage float and mechanism



2. With the water tray removed the 2 outer deflector trays may be removed, (these cannot be removed with the water tray in place).



CARE MUST BE TAKEN WHEN CLEANING THE INTERIOR OF THE MACHINE BECAUSE ELEMENTS, PANELS ETC. MAY REMAIN HOT FOR SOMETIME AFTER THE HEATING HAS BEEN SWITCHED OFF.

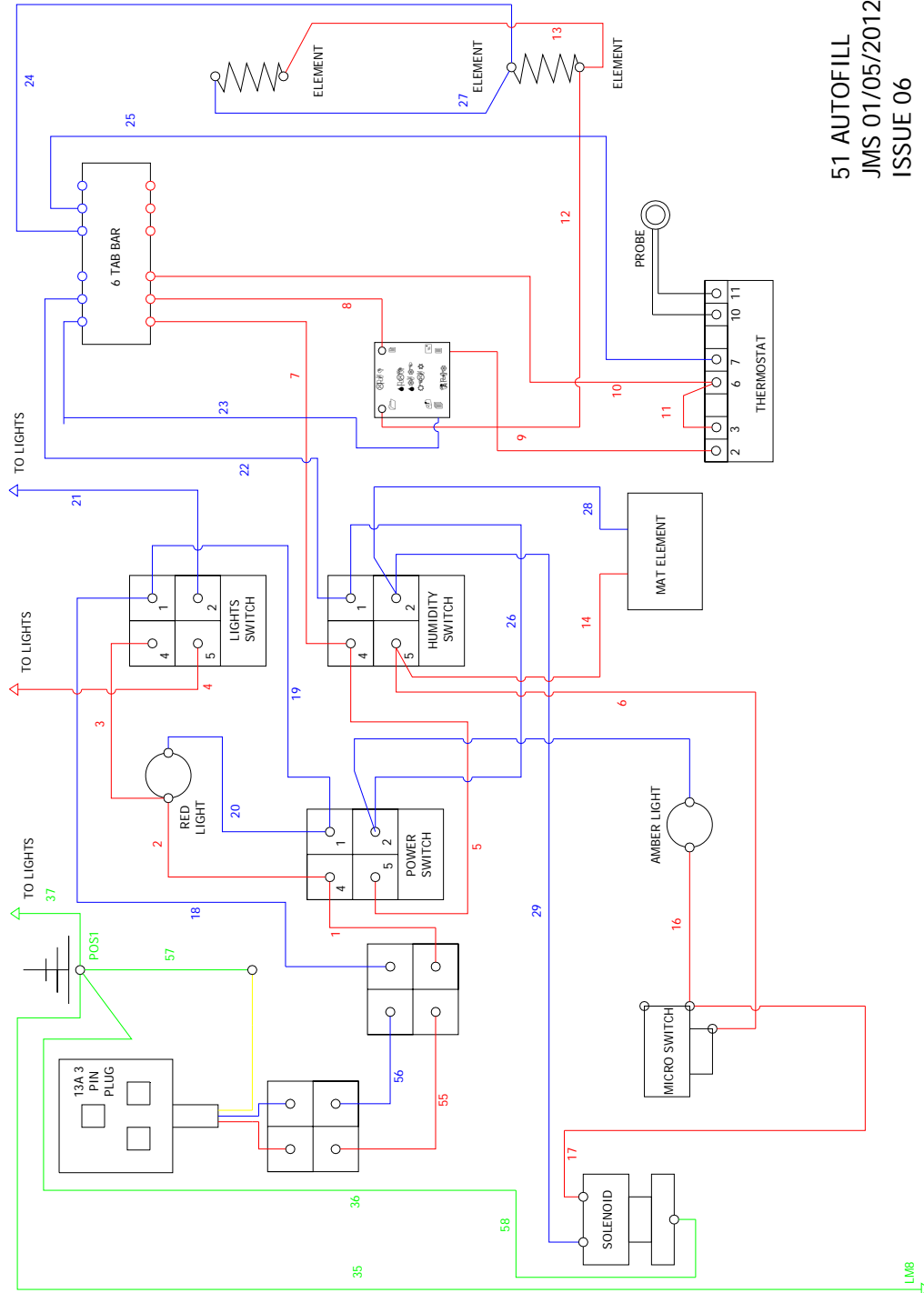

51 AUTOFILL
 JMS 01/05/2012
 ISSUE 06

SPARE PARTS LIST

PART NO.	PART NAME	QTY.	
MF515-767	MICRO SWITCH WITH ROLLER 515-767	1	
MFRC12/04	BRASS M/M ADAPTOR	1	
MFFFR12/04	BRASS F/F ADAPTOR	1	
MFMCU7061/4	FLOW CONTROL	1	
MF20231/4-1/4	FLOW CONTROL CONNECTION RING	1	
MFF4PB6-1/4	MALE STRAIGHT FITTING 1/4 TO 6MM TUBE	3	
MFWADE-MC106/081	6mm x 1/8 BSPP MALE STUD COUPLING	1	
MFWADE-ME106/083	6mm x 1/8 BSPT MALE STUD ELBOW	1	
MFHPB6	6mm – 6mm STRAIGHT CONNECTOR`	1	
MFVM04	BALL VALVE	2	
MF51FLOAT	FLOAT FOR WATER TRAY	1	

PART NO.	PART NAME	QTY.	
VISW15	GREEN SWITCH	2	
VISW17	RED SWITCH	1	
MFPU22001-230V1/8	2 WAY SOLENOID VALVE NC, 1/8" F > 1/8" F	1	
MFMT11TIRES	DIGITAL THERMOSTAT WITH PROBE	1	
MFLA100	OVEN LAMP	12	
MFSP25-15	INCOLOY ELEMENTS 750W	3	
MFG9-40WBULB	REPLACEMENT BULB	12	
GSGAST160	PAN WIRE INSERT	6	
VILE14	SWITCH MEMBRANE	3	

PART NO.	PART NAME	QTY.	
MFNE30	RED NEON	1	
MF NE61	AMBER NEON	1	
GSGAST40022	1/1 PAN 65MM DEEP	1	
GSGAST40002	1/1 GASTRONOME PAN 20MM DEEP	6	
MF225WELEMENT	WATER TRAY MAT ELEMENT	1	
MF51RHSPRING	RIGHT HAND DOOR SPRING	6	
MF51LHSPRING	LEFT HAND DOOR SPRING	6	
MFLTR035G04S	FLOAT SPRING	1	
MFRELAY25A230V	SOLID STATE RELAY	1	

Cleaning instructions - Daily

1. Disconnect the machine from the power supply before cleaning and allow to cool.
2. Remove food gastronorm pans and wire insets, wash thoroughly in warm soapy water, rinse and dry.
3. Remove the spacing racks and wash in warm soapy water, rinse and dry.
4. Doors may be wiped with a soft damp cloth, dry thoroughly taking care not to damage the plastic.
5. Remove the water tray assembly, lift the float and take out water gastronome plan and clean thoroughly, (take care not to damage float assembly).
6. Note once the bottom water tray assembly has been removed the two outer trays May be removed and wiped clean.

NEVER use wire wool, scourers, abrasive cleaners, acids or bleach.

DO NOT flood or allow electrical parts to become wet.

NEVER handle the lamps; if they become dirty they should be wiped with a soft, damp, grease free cloth.

DO Dry all surfaces thoroughly removing all moisture.

A stainless steel cleaner/polish may be applied to the exterior.

N.B - For Hard Water Areas

To avoid the risk of scale build up, we advise to either fit an in-line softener if using the mains supply or use a water softener. If the unit is being used with a remot water tank use de-ionised water.

Please be aware of these guidelines as scale is not covered by our warranty, as noted earlier in this manual

FAULT FINDING

Any servicing must only be carried out by qualified personnel. Unit must be removed from electrical supply before servicing.

Problem	Probable Cause	Solution
1. Indicated ON/OFF switch does not light up	No power to machine. ON/OFF switch faulty	Check machine is plugged in and switched on. Check fuse in 13a plug, replace if faulty. Check circuit breaker at main supply board is in (ON). Check Switch, replace if faulty.
2. Digital thermostat does not indicate temperature reading.	ON/Off switch OFF Unit overheated ON/OFF switch faulty Digital thermostat faulty	Switch ON Allow to cool. Replace switch Replace if thermostat faulty
3. Lamps do not work	No power Green switch OFF Lamp not correctly seated. Faulty lamp	See section 1 Switch ON Adjust to required setting. Check fitted correctly Replace lamp
4. Unit does not heat up.	No power to machine ON / OFF switch off ON / OFF switch faulty Digital thermostat faulty Thermocouple faulty Switching relay faulty Heat element faulty	See section 1. Switch ON Replace Switch Replace thermostat As indicated on controller replace thermocouple Replace relay Replace element

Problem	Probable Cause	Solution
5. No water flow	Flow valve shut. Solenoid valve faulty. Water lime blocking pipe/valve system. Water drawer not in and locked.	Open flow regulator valve to suit. Replace valve. Remove system and clear or replace. Check micro switch – replace as necessary.
6. LED does not light	Humidity Switch Off Circuit Faulty Water drawer not in and locked	Switch On. Check and replace if necessary. Check micro switch – replace as necessary.
7. Water supply does not flow.	ON/OFF switch off. Mains Water Off. Bottle Empty. Faulty Solenoid.	Switch on. Switch on. Fill Bottle Replace Solenoid.

Terms and Conditions

Claims

No claim shall be entertained by the Company unless made in writing. Claims arising from damage or partial loss in transit must reach the Company within 7 days from the date of delivery. Claims for non-delivery must reach the Company within 10 days from the date of dispatch. All other claims must reach the Company within 7 days. Damaged goods must be retained for inspection/collection.

Returns

The Company does not operate a returns policy unless the goods are defective:

In circumstances where the Company agrees to accept return of goods, a charge of 25% of the invoice value will be made.

Damage claim form

Machine: **1100 AUTO FILL PASS-THRU INDIVIDUAL FLAP**

Product code: **EQVI1100PTWIFPT**

Customer name.....

Date of delivery.....

Machine serial number.....

Damage comments.....

.....
.....
.....
.....
.....

Please indicate on the picture where the unit is damaged

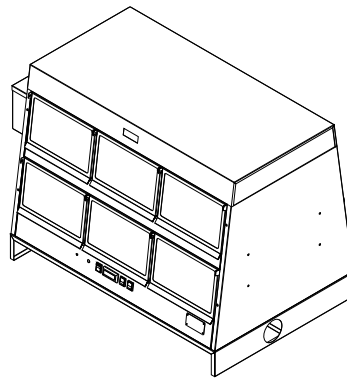
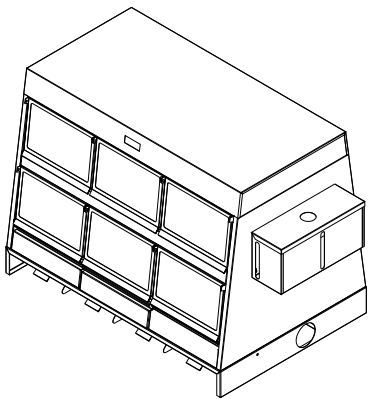

Courier name.....

Please cut this page out and post to **Fast Food Systems**

(The address is on the back of this manual)



Warranty

UNITED KINGDOM AND REPUBLIC OF IRELAND

Excepting where otherwise specified all products are subject to 12 months parts and labour warranty. Goods found defective will be repaired, credited or replaced without charge according to the terms of the Company's standard warranty, provided written notice is given within the guarantee period. In no case will the company be liable for repairs made without its knowledge or sanction, or for indirect damage, or any consequential loss or expense incurred by purchasers.

Fast Food Systems Ltd, warrants to the original purchaser that the equipment supplied to be free from defective materials or workmanship for a period of 12 (twelve) months.

The following are NOT covered by warranty:

1. Failure or breakdown caused by incorrect installation.
2. Glass parts, electric lamps or door seals.
3. Adjustment or calibration of controls - this is a routine maintenance function.
4. Abuse or misuse, including cleaning.
5. Warranty labour is only carried out during normal working hours; calls attended to out of hours may be subject to surcharges.
6. The warranty will commence either on installation or 1 (one) month from date of dispatch - whichever is the sooner.
7. Warranty on spare parts purchased for equipment outside of the warranty period is 3 (three) months from date of sale.
8. Any faulty spare parts replaced under warranty must be returned with 7 days of supply.
9. Warranty is non-transferable.

Fast-Food-Systems Ltd will not be held responsible, financially or otherwise, for any loss of business as a result of equipment breakdown.

Notes....

Model Number.....

Order ID/Job No.....

Machine serial number.....

Date of Manufacture/...../.....

Date of delivery...../...../.....

Date of Commissioning...../...../.....



ENGLISH

Electrical equipment marked with this symbol may not be disposed of in European public disposal systems after 12 August 2005. In conformity with European local and national regulations (EU Directive 2002/96/EC), European electrical equipment users must now return old or end-of-life equipment to the manufacturer for disposal at no charge to the user.

Note: For return for recycling, please contact the equipment manufacturer or supplier for instructions on how to return end-of-life equipment for proper disposal.

Fast Food Systems Limited

Manufacturer & Distributor of Catering Equipment

Unit 1 Headley Park 9 Headley Road East

Woodley Reading Berkshire RG5 4SQ

Tel: 0118 944 1100 Fax: 0118 944 0350

Email: service@fast-food-systems.co.uk

Website: www.fast-food-systems.com

ISSUE: 13

14 January 2014