

# Clam Griddle

*EQVICG450M*

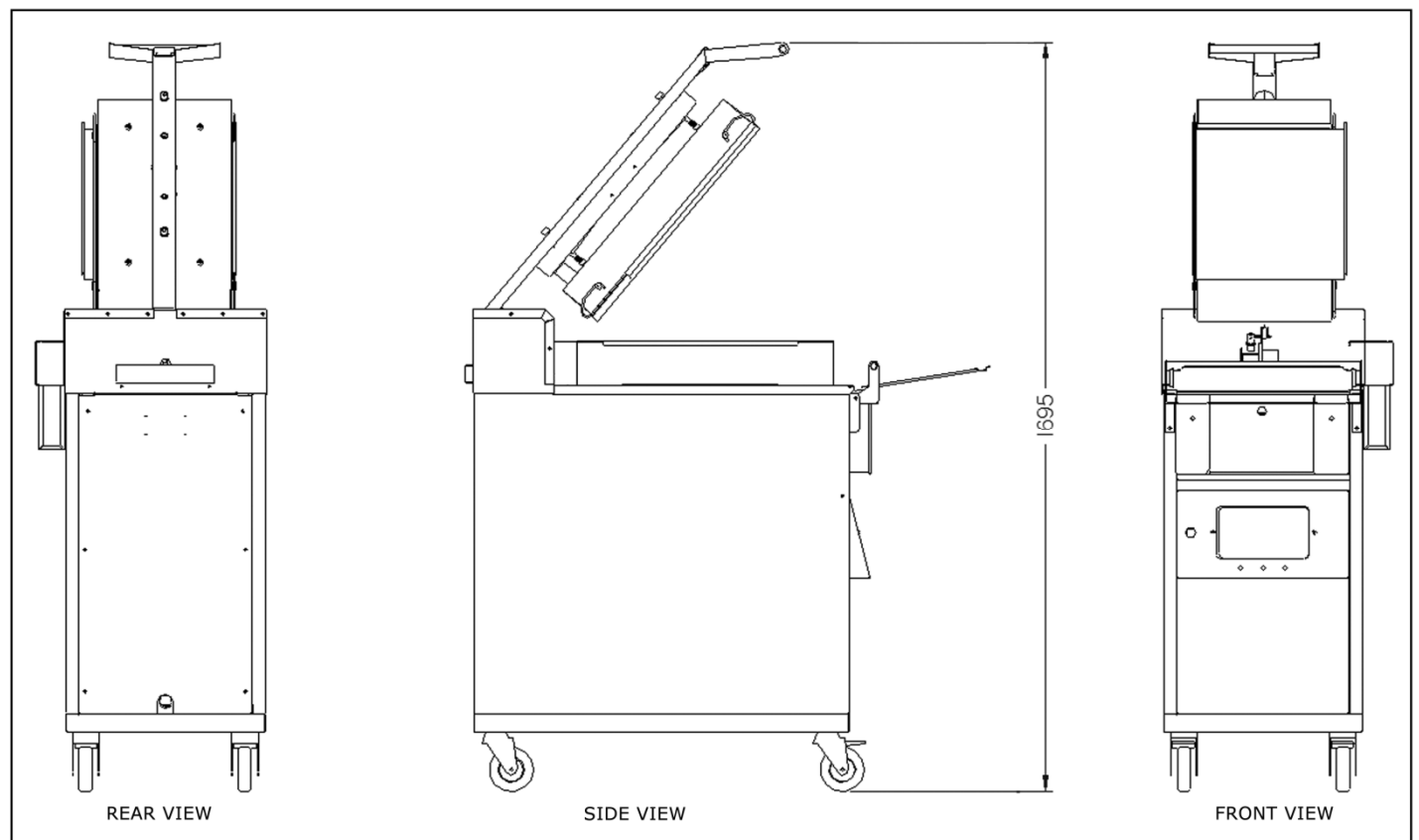

- Ideal for a variety of different products.
- Easy to use 'One Touch' Fastron controller with 10 cooking programs to ensure consistent product.
- Audible alarm and self-lifting top plate limit wasted product.
- Built for simple operation and easy cleaning.
- Optional ribbed top plate for char- grilled cooking.

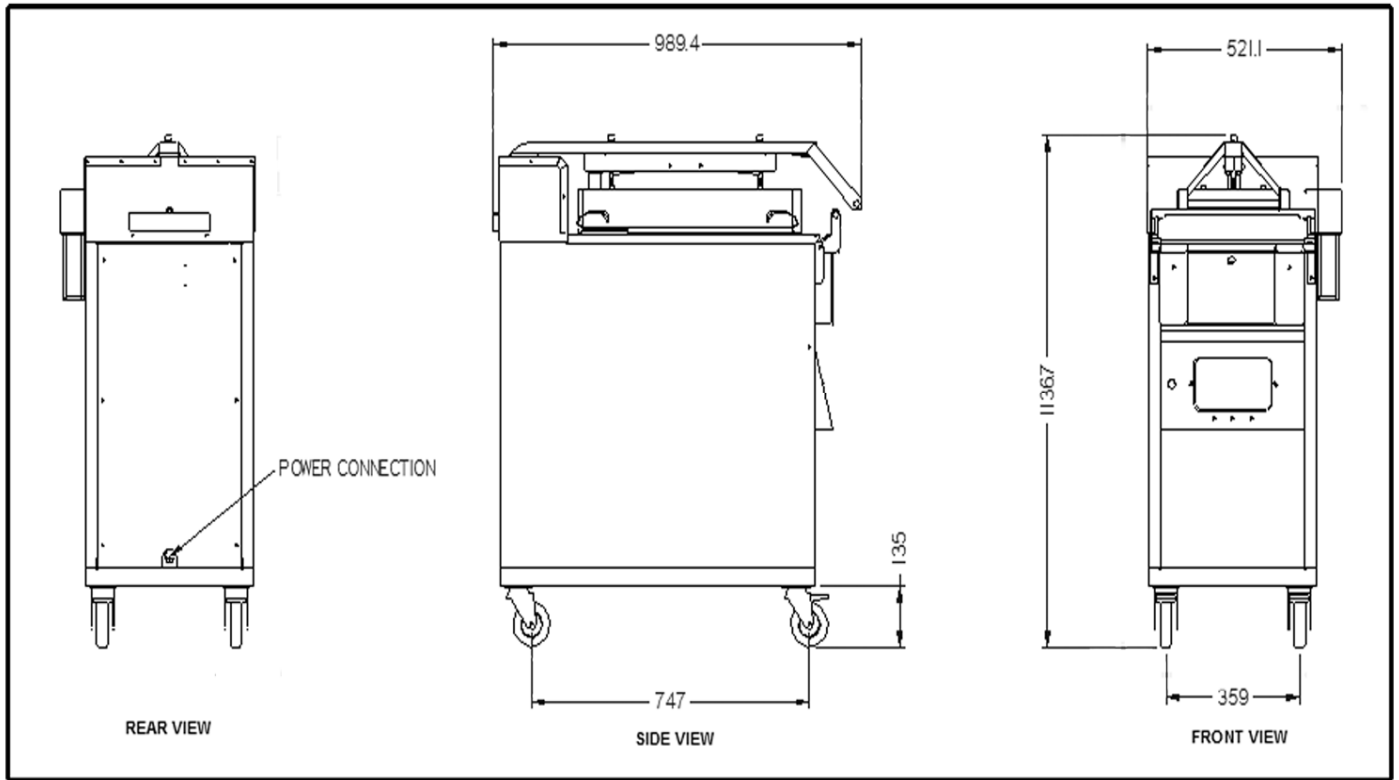

**Model EQVICG450M**

<b>Dimensions</b>	<b>Machine</b>
Height	1140mm
Width	525mm
Depth	990mm
<b>Weight</b>	110kg
<b>Electrical</b>	3 phase, 50HZ AC, 415v, 9Kw
Running Amps	39 Amps
Connection Type	5 Pin plug
International Option	N/A

All **Vizu Clam Griddles** have been tested and checked for proper operation before leaving the factory.

Upon delivery please check the unit for damage. If the unit is damaged, contact the carrier, or fast food systems, immediately and file a damage claim (found in the back of the manual) Please retain all packing materials.

Damage must be reported within 7 days of delivery

**General Description**

Meat of all kinds can be cooked on the Vizu Clam Grill.

Once the appropriate cooking program has been selected the appropriate cooking program has been selected the product is placed on the hot griddle plate. The top clam platen is pulled down and latches shut, beginning the cooking cycle, after which the machine will automatically open.

## **Assembly Instructions**

Remove all packing from the unit.

Peel off all protective plastic covering from metal

## **Installation**

Position the *Vizu Clam Griddle* in desired position, close to a suitable electrical supply and connect.

Note: this unit is three phase so with plug supplied

## **Operating Instructions**

1. Switch the Clam on by pressing the green button located on the front panel.
2. If necessary switch on the controller by pressing the On/Off button located in the bottom left corner.
3. Select the desired product by pressing the relevant button, e.g. for 4oz burger select button 2.
4. When the cooking plate has reached the pre-set temperature the display will show TOP-REDY and BOT-REDY. Allow 20 minutes for this.
5. Place the product on to the grill surface. NO OIL IS REQUIRED.
6. Pull the Clam down using the handle.
7. Pull the handle down until the Clam is fully closed. The timer will beep and the latch will hold the Clam closed until the timer finishes.
8. At the end of the pre-set cooking cycle the timer will beep and the Clam will open automatically.
9. Remove the cooked products with a spatula.
10. After each batch of product, wipe the Teflon using the rubber bladed squeegee – this removes the grease.
11. Scrape the chrome platen using the scraper. Hold the scraper with 2 hands at an angle of 45° push down firmly and remove all the grease and debris.
12. Use the trough tool to clean the side of the grill platen.

## **Cleaning Instructions**

1. Switch the grill off by pressing the red off switch located on the front panel
2. Clean the 'non-stick' sheet with the rubber squeegee.
3. Clean the grill surface with ice. Tip a handful of ice on to the grill surface. (If ice is not available use warm water)
4. Use the scraper to thoroughly scrape the grill surface. The ice will loosen the debris and help remove the grease.
5. Use the brass wire brush and some more ice to scrub away stubborn stains.
6. When the grill is cool sprinkle a little some Keating Klenzer on to the grill surface and add some water to make a paste.
7. Then polish the surface grill with paper roll.
8. Remove and clean the grease troughs.
9. Clean all the stainless steel surfaces of the grill with non-chlorine based de-greaser.
10. Wipe the entire surface with paper towel
11. When the grill has cooled sufficiently, remove the 'non-stick' sheet by unclipping the four clips at the corners
12. Clean the 'non-stick' sheet with a non-abrasive cloth or sponge and some normal washing up liquid.
13. Rinse under clean water to remove any detergent.
14. Replace the 'non-stick' sheet carefully.

## Controller Features

### PROGRAMMING CODES

Product Programming	1 7 2 4
System Programming	3 2 2 8
Boil Mode	1 7 2 4

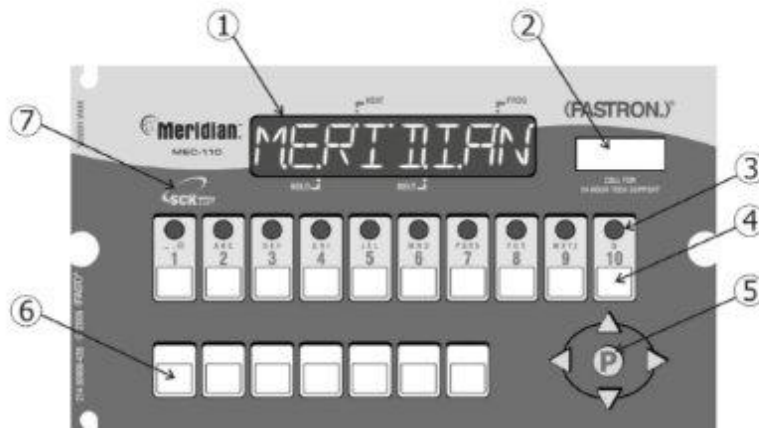

- |   |  |
|---|--|
| 1 | LARGE LED DISPLAY: 8-character, 14-segment. Displays programming and cook cycle information.   |
| 2 | SERVICE WINDOW: Locate the controller's serial number and tech support phone number easily.  |
| 3 | INDICATOR LIGHTS: lit when there's an active cook cycle and in programming mode.   |
| 4 | PRODUCT KEYS: Press to start a cook cycle. Also used in programming.<br>REPLACEABLE MENU STRIP: Make menu changes quickly and easily.  |
| 5 | (FAST.Nav) <sup>™</sup> PROGRAMMING CENTER: Easy mobile phone-like programming. Access programming mode and change cooking parameters. |
| 6 | FEATURE KEYS: Used to access programming functions and controller features; keys will vary by model.                                   |
| 7 | SCK LINK <sup>®</sup> : Signifies that your control is communications-capable.   |

This document contains confidential information. The dissemination, publication, copying, or duplication of this document or the software described herein without prior written authorization is strictly prohibited.

## Feature Definitions

---

### **Programmable Action Alarms**

Up to three action alarms can be programmed for each product key. An action alarm alerts the operator to perform some action at a pre-programmed time.

### **Programmable Appliance Type**

A specific type of appliance; i.e., gas, electric or generic can be programmed into the controller.

### **Energy Saving Manual Setback**

Setback, an energy-saving feature, will lower the temperature of the oil after a pre-determined amount of inactive time (1 to 59 minutes). Temperature is programmable from 200-300°F (93.3-148.8°C). Enter setback mode by pressing the SETBACK key. The controller will display COOL or SETBACK and will control the appliance to the programmed setback temperature.

### **Fahrenheit or Celsius Temperature Display**

The controller can be configured to display the temperature in degrees Fahrenheit or Celsius (accessible through System Programming mode).

### **Programmable (FAST.Flex)<sup>™</sup> Timing Mode**

Flex or straight timing can be configured for each stage on each product key. To insure consistent, high-quality food product, flex time will adjust the actual cook time taking into consideration the temperature variation due to load size, initial product temperature, product moisture content, and other factors affecting the cook cycle. If cooking by straight time, the controller will cook only for the specified time without adjusting for these variations.

### **Programmable Filter Lockout Cycle Count**

Ensure good-tasting food is always served to your customers by requiring the oil be filtered after "x" amount of times. Any product key with Filter Lockout programmed will cease to operate until the oil is filtered. A filter lockout cycle count (valid range 0 to 99) can be programmed for each product key. To disable filter lockout, enter 0 for the filter lockout count.

### **Programmable Global Filter Lockout**

A single filter lockout cycle count can be programmed to apply globally to all product keys.

### **Programmable Hold Time Linking**

Each product key can be linked to an independent hold timer, or multiple product keys can be linked to a single hold timer.

### **Programmable Hold Times**

Product key hold times can be programmed to track product quality through a specified holding period. Hold time countdown begins as soon as the cook cycle is complete. The controller will sound an alarm when the product's hold time has expired alerting the operator to discard the product.

### **Automatic Least Hold Display**

Product with the least amount of hold time remaining will be shown in the display. Pressing and holding the SCAN key allows you to view each active product's remaining hold time.

### **Melt Cycle**

If the vat temperature is below the Melt Limit Temperature and the controller is ON, it will control the melting of the oil.

### **Programmable Operating Mode**

The controller can be programmed to operate as either a controller or timer.

### **Programmable Pressure Valve**

The pressure valve state for each stage on each product key can be programmed. The valve can be open or closed.

Note: The valve is normally open when not cooking.

### **Programmable Stage Temperatures**

Cook temperatures for each stage on each product key can be programmed. The valid temperature range is 200°F to 400°F (93.3°C to 204.4°).

### **Programmable Stage Times**

Cook times for each stage on each product key can be programmed. The controller is programmable in minutes (up to 99) and seconds (up to 59) and allows up to ten stages per product key.

NOTE: Multiple cook starts are not allowed if a product key has more than one stage programmed.

## Operating the Controller

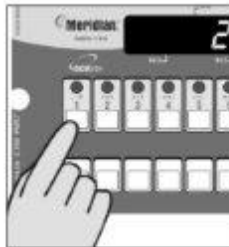

### Start a Cook Cycle

Press any product key to start a cook cycle. If the key is programmed, the correct cooking time will be displayed and will immediately start to count down in minutes and seconds. DONE will display when the cook cycle has ended.

The pressure solenoid will also close if programmed to do so, or a basket lift will lower if so equipped.

If DONE is displayed immediately and the unit starts to signal, the product key being pressed is not programmed.

### Stop a Cook Cycle

Press and hold an active product key for 3 seconds. Timing will stop.

### Respond to a DONE Alarm

Cancel the signal by pressing the same product key used to start the cook cycle.

### Action Alarms

If the controller is programmed for action alarms, they will signal at a preset time during the cooking cycle. The signal, a dual-rhythm beeping, will last 5 seconds and then self-cancel. The display will flash the action alarm time and the controller will start counting toward 0:00.



### Holding Timers

If the controller is programmed with holding times, they will automatically start counting upon expiration of the cooking cycle.

When there are active hold times, the HOLD indicator light will be lit.

**To View All Active Hold Times**, press and hold the HOLD key. Upon expiration, the timer will display HOLD and pulse with an audible tone. To acknowledge, press the HOLD key.

## Operating the Controller

### Boil Mode



**CAUTION: THE USER MUST CONSULT AND FOLLOW THE APPLIANCE MANUFACTURER'S GUIDELINES FOR CLEANING AND BOILING OF THE FRY VATS.** If your fryer manufacturer recommends this procedure, the boil function accurately maintains the fryer temperature at 190°F (88°C) to assist in the cleaning of fry vats. To start the boil process, turn the appliance OFF. Empty the fry vat of oil. Once the vat is emptied of oil and refilled with cold water, the controller and fryer may now go into boil mode.

The fry vat must be below a temperature of 200°F (93.3°C) to enter the boil mode.

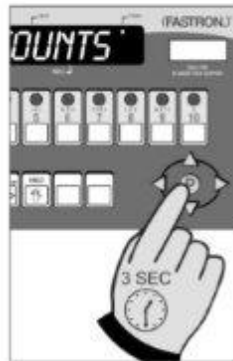

**NOTE:** The fry vat will maintain a temperature of 190°F (88°C) to allow the boil function to be performed.

**To Enter Boil Mode:** Press and hold the P key for 3 seconds. COUNTS will be displayed.

Press the up or down arrow keys until BOIL is displayed, then press the P key. BOIL will be displayed.

**To Exit Boil Mode,** press and hold the P key for 3 seconds. COUNTS will be displayed.

Press the up or down arrow keys until BOIL is displayed, then press the P key. The controller has now exited boil mode. If unit has an ON/OFF, you can also exit by turning the unit OFF then back ON.



**CAUTION: Refill the vat with oil ONLY when it is completely dry.**

### Fill Mode

If the controller is programmed for filter lockout, FILTER will appear in the display after the pre-programmed number of cook cycles allowed. The controller will stop operating until the fryer is filtered. After filtering, the display will read FILL. **At this time, the fryer MUST be refilled with oil.** When this step is complete, press ENTER to resume normal operations.



## Operating the Controller

### Product Counts

**To Check Product Counts:** press and hold the P key for 3 seconds. COUNTS will be displayed.

Press the P key. PROD 1 will be displayed then the number of cooks that were completed on that key. To see the number for each key, continue to press the P key and each product will display PROD X then the number of cooks.



**Resetting the Product Counts:** Once you go through all keys, the display will show CLRPROD then NO. Use the left and right arrow keys to toggle between YES and NO. Choose YES to reset your product count or NO to save the cook counts that have already been completed. Then press the P key.

The display will show GLOBAL. This is the total product count of all keys combined. Press the P key again. CLRGLOBL then NO will be displayed. Use the left and right arrow keys to toggle between YES and NO. Choose YES to reset your total product count or NO to save the total cook counts that have already been completed. Then press the P key. TOTALX10 is displayed, then a number. Press the P key again.

**To Exit Product Counts:** COUNTS will be displayed. Press the up arrow key. EXIT will be displayed. Press the P key. The controller will exit programming mode.

### Display Descriptions

**LO**

Controller is in Operating Mode. Actual vat temperature is more than 10 degrees below the programmed vat temperature.

-----

Controller is in Operating Mode. Actual vat temperature is within the proper cooking temperature range. The vat is ready to start a cook cycle.

**DROP  
READY**

**HI**

Controller is in Operating Mode. The actual vat temperature is more than 40 degrees above the highest programmed vat temperature. A continuous audible alarm will sound.

**PROBE**

Controller's probe is either open or shorted. Display will be accompanied with an audible alarm if shorted. Check or replace the probe.

**2:30**

Controller is in Operating Mode and a cook cycle is in progress.

**DONE**

Controller is in Operating Mode and a cook cycle has been completed.

This document contains confidential information. The dissemination, publication, copying, or duplication of this document or the software described herein without prior written authorization is strictly prohibited.

## Display Descriptions

<b>CODE</b>	Controller is waiting for a pass code to be entered.
<b>PRODUCT</b>	Controller is in Product Key Programming Standby mode.
<b>TIME 1</b>	Stage cooking time (1-10) is displayed.
<b>TEMP 1</b>	Stage cooking temperature (1-10) is displayed.
<b>TIMING 1</b>	Stage timing mode (1-10) (flex or straight) is displayed.
<b>PRESS 1</b>	Solenoid condition (1-10) (open or close) is displayed.
<b>ALTIME1</b>	Action alarm status is displayed.
<b>FILL</b>	After fryer is filtered, this display prompts you to refill the fryer with oil.
<b>SYSTEM</b>	Controller is in System Programming Standby Mode.
<b>TEMPUNIT</b>	Controller is in Fahrenheit or Celsius Programming Mode.
<b>APPLIANC</b>	Controller is in Appliance Type Programming Mode.

## Programming: PRODUCT KEY

-  18 button controllers have two displays that show a full line of information; for example:  

- 10 button controllers have a single, dual-purpose display that will alternate information; for example:  

### RECIPE 1724 STORE EMPLOYEE

#### ENTER PROGRAMMING MODE.

Press and hold the P key for 3 seconds.



#### COUNTS

Press the down arrow key.



#### PROGRAM

PROGRAM will be displayed. Press the P key.



## Programming: PRODUCT KEY



Some controllers may have different options listed.

Depending on model, you can either press the P key to change all programmable settings or you can scroll using the arrow keys to any of the specific options.

### CODE

Type in 1 7 2 4 using the product keys. Press the P key.

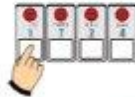

### RECIPE

Press the P key. All product key LEDs will light up.



### PRODUCT

**PROGRAM A PRODUCT KEY.** Press the product key you want to program. Press the P key.



### ALL

Press the P key.



### NAME

XXXXXXXX

**SET PRODUCT DISPLAY NAME.** NAME will be displayed then the actual product name. Use the up and down arrow keys to scroll through the library. Press the P key to lock in your choice.



### TIME 1

XX:XX

**SET COOK TIME.** Actual set time will be displayed. To change, press toggle clear to change the time to zero. Type in a new time using the product keys. Press the P key.

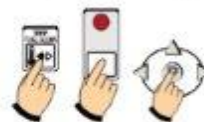

### TEMP 1

XXX.F

**SET COOK TEMPERATURE.** Actual set temperature will be displayed. To change, press toggle clear to change the temperature to zero. Type in a new temperature using the product keys. Press the P key.

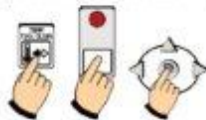

### TIMING 1

STRAIGHT

FLEX

SENSITIV

**SETTING MODE.** Use the left and/or right arrow keys to choose Straight, Flex or Sensitivity. Press the P key.



### PRESS 1

OPEN

CLOSED

**SET SOLENOID MODE.** Use the left or right arrow keys to choose either OPEN or CLOSED. Press the P key.



Some models have up to 3 action alarms.



**NOTE:** On some models, each product key can be programmed with up to 10 stages. If no additional stages are required at this point, set the time to zero. Press the P key to continue to Action Alarm.

### TIME 2

XX:XX

**SET COOK TIME #2.** Actual cook time will be displayed. To change, press toggle clear to change the time to zero. Type in a new time using the product keys. Press the P key. Repeat above steps.



### ALARM 1

XX:XX

**SET ACTION ALARM.** Actual alarm time 1 will be displayed. To change, press toggle clear to change the time to zero. Type in a new time using the product keys. Press the P key.



Programming: PRODUCT KEY

**ALMNAME1**  
XXXXXXXX

**SET ACTION ALARM NAME.** ALMNAME1 will be displayed, then the actual action alarm name. Use the up and down arrow keys to scroll through the library. Press the P key to either go to next action alarm name, or continue through programming.



**HOLDTIME**  
XX:XX

**SET HOLDTIME.** Actual hold time will be displayed. To change, press toggle clear to change the time to zero. Type in a new time using the product keys. Press the P key.



**FILTRCNT**  
X  
NONE

**SET FILTER COUNT.** Actual filter count will be shown (1-99 or NONE). Use the left and right arrow keys to set a new filter count. Press the P key.



**ALL**

**EXIT PROGRAMMING MODE.** Press the up arrow key.



**EXIT**

Press the P key.



**PRODUCT**

Either press another product key to program and repeat the programming instructions, or exit by pressing the up arrow key.

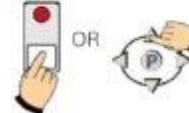

**EXIT**

Press the P key.



**RECIPE**

Press the up arrow key.



**EXIT**

Press the P key.



Programming: SYSTEM

**SYSTEM 3228  
STORE MANAGER**

**ENTER SYSTEM PROGRAMMING MODE.** Press and hold the P key for 3 seconds.



**COUNTS**

Press the down arrow key.



**PROGRAM**

PROGRAM will be displayed. Press the P key.



**CODE**

Type in 3 2 2 8 using the product keys. Press the P key.



**SYSTEM**

Press the P key.



**APPLIANC**

**GAS**  
**ELEC**  
**GEN**

**SET APPLIANCE MODE.** Use the left and/or right arrow keys to choose Gas, Electric or Generic. Press the P key.



This document contains confidential information. The dissemination, publication, copying, or duplication of this document or the software described herein without prior written authorization is strictly prohibited.

Programming: SYSTEM

**CTRTYPE**

**TEMPCTRL**  
**TIMECTRL**

**SET CONTROL TYPE.**

Use the left and/or right arrow keys to choose Temperature or Time Control. Press the P key.



**TONEVOL**

**SET TONE VOLUME.** Use the left and/or right arrow keys to choose 1, 2, 3, 4 or NONE. Press the P key.



**TEMPUNIT**

**F**  
**C**

**SET TEMPERATURE SCALE.** Use the left and/or right arrow keys to choose Fahrenheit (F) or Celsius (C). Press the P key.



**PREHEAT**

**YES**  
**NO**

**SET PREHEAT MODE.**

Use the left and/or right arrow keys to choose Yes or No. Press the P key.



**SETBTIME**  
**COOLTIME**

**XX:XX**

**PROGRAM SET BACK**

**TIME.** Actual set time will be displayed. To change, press toggle clear to change the time to zero. Type in a new time using the product keys. Press the P key.

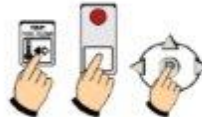

**SETBTEMP**  
**COOLTEMP**

**XXXF**

**PROGRAM SETBACK**

**TEMPERATURE.** Actual set temperature will be displayed. To change, press toggle clear to change the temperature to zero. Type in a new temperature using the product keys. Press the P key.



**FILTRCNT**

**X**

**SET FILTER COUNT.**

Actual filter count will be shown (1-99). To change, press toggle clear to change the count to zero. Type in a new filter count using the product keys. Press the P key.

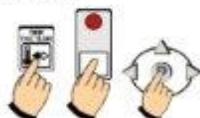

**COOKUNIT**

**MM:SS**  
**HH:MM**

**SET COOK TIME UNIT.**

Use the left and/or right arrow keys to choose Minutes/Seconds or Hours/Minutes. Press the P key.



**HOLDUNIT**

**MM:SS**  
**HH:MM**

**SET HOLD UNIT.**

Use the left and/or right arrow keys to choose Minutes/Seconds or Hours/Minutes. Press the P key.



**SYSTEM**

**EXIT SYSTEM PROGRAMMING MODE.**

Press the up arrow key.



**EXIT**

Press the P key.



**READY**

You have now EXITED System Programming Mode and can operate the controller.

## Programming: OFFSET

### SYSTEM 3228 STORE MANAGER



Offset Temperature can be set from 20 to -20F (-6.6 to -28.8C).

#### ENTER OFFSET PROGRAMMING MODE.

Press and hold the P key for 3 seconds.



#### COUNTS

Press the down arrow key.



#### PROGRAM

PROGRAM will be displayed. Press the P key.



#### CODE

Type in 3 2 2 8 using the product keys. Press the P key.



#### SYSTEM

Press the down arrow key UNTIL Offset is displayed.



#### OFFSET

Press the P key.



#### XXF XXC

Use the product keys to enter a new offset temperature. to change from negative to positive, use the left and right arrow keys. Press the P key.



#### OFFSET

#### EXIT OFFSET PROGRAMMING MODE.

Press the up or down arrow keys to scroll to EXIT. Press the P key.



#### EXIT

Press the P key.



#### READY

You have now EXITED Offset Programming Mode and can operate the controller.

## Programming Custom Product & Action Alarm Names to the Library

### SYSTEM 3228 STORE MANAGER

#### ENTER LIBRARY PROGRAMMING MODE.

Press and hold the P key for 3 seconds.



#### COUNTS

Press the down arrow key.



#### PROGRAM

PROGRAM will be displayed. Press the P key.



#### CODE

Type in 3 2 2 8 using the product keys. Press the P key.



#### SYSTEM

Press the down arrow key to select either PRODLIBR OR ALRMLIBR.



#### PRODLIBR

#### ALRMLIBR

Choose either PRODLIBR (Product Library) or ALRMLIBR (Action Alarm Library) by pressing the P key.



A flashing dash will be displayed. Press the SCAN key and use the product keys to spell a new word. Press the right arrow key to advance to the next character position.



Continue spelling the word. When done, press the P key.



**TO SAVE WORD**, press P again. Skip to Exit Library Programming.



**TO CANCEL OR MODIFY**, see next step.

#### ADD

#### CANCEL

#### MODIFY

**TO CANCEL OR MODIFY WORD**, press the left or right arrow keys to select CANCEL or MODIFY.



IF YOU CHOOSE CANCEL:

#### CANCEL

Press the P key to EXIT and cancel the word.



IF YOU CHOOSE MODIFY:

#### MODIFY

Press the SCAN key to go back and modify the word.



#### PRODLIBR

#### ALRMLIBR

**EXIT LIBRARY PROGRAMMING.** Press the up or down arrow keys until display reads EXIT.



#### EXIT

Press the P key.



#### READY

You have now EXITED Library Programming Mode and can operate the controller.

This document contains confidential information. The dissemination, publication, copying, or duplication of this document or the software described herein without prior written authorization is strictly prohibited.

## **Faultfinder**

Any servicing must be carried out by qualified personnel.

Disconnect from power before servicing.

<b>Problem</b>	<b>Possible cause</b>	<b>Solution</b>
Plugged in, power available – 3 LED's on control box not lit	1a Check supply fuses  1b MCB tripped/fault  1c Plug/socket fault (on back of control box) 1d Check MCB input & output when switched in 'ON' position	1aa Check at contactors B+C to element side, down to earth – replace as necessary. 1bb Possible trip due to spike in power supply – reset and try machine.  1cc Check connections.  1dd Replace as necessary.
Power available, LED's illuminated, no top heat	2a Check elements as per procedure 1aa. (Contactor 'B' for top heat), open circuit? 2b Check that contactor is closing. 2c Check 24V supply.  2d With contactor closed check voltage in and voltage out. 2e Check that 1000Ω reading on probe (when at room temperature). 2f Check relay '2' illuminated (input + output of 24V).  2g Check wiring for breaks and/or bad connections.	2aa Replace element as necessary.  2bb Replace if necessary.  2cc Replace transformer as necessary.  2dd If voltage IN is ok, but NO output, replace contactor. 2ee Incorrect reading, replace probe  2ff If input is ok, but NO output, then replace relay.  2gg Repair/replace as necessary.

**Faultfinder (Continued 1.)**

<b>Problem</b>	<b>Possible cause</b>	<b>Solution</b>
Power available, LED's illuminated, no bottom heat	3a Check elements as per procedure 1aa. (Contactor 'C' for bottom heat), open circuit? 3b Check that contactor is closing. 3c Check 24V supply. 3d Check that the contactor is closing and has voltage in and voltage out. 3e Check that 1000Ω reading on probe (when at room temperature). 3f Check relay '3' illuminated (input + output of 24V). 3g Check wiring for breaks and/or bad connections.	3aa Check at contactor 'C' to element side, for OPEN circuit. 3bb Replace if necessary. 3cc Replace transformer. 3dd If voltage IN is ok, but NO output, replace contactor. 3ee Incorrect reading, replace probe. 3ff If input is ok, but NO output, then replace relay. 3gg Repair/replace as necessary.
Lights on controller fail to switch on.	4a Check plugs and sockets for breaks and/or bad 4b Check fuses 1+ 2. 4c Check green/red button for proper action (normally closed – red button, normally open green 4d Check contactor 'A', (normally open). 4e With green button held, does the machine switch on? But fails when button released?	4aa Correct as necessary. 4bb Replace if faulty. 4cc Check for closure. 4dd Replace if faulty. 4ee Replace top section of contactor 'A'.

Faultfinder (Continued 2.)

<b>Problem</b>	<b>Possible cause</b>	<b>Solution</b>
	4f Press green button and hold – check for input + output on 24V transformer. 4g Check over temperature thermostat (should be normally closed). 4h Internal failure of controller.	4ff Replace transformer if there is NO output. 4gg Check for breaks/bad connections, replace over temperature thermostat as necessary. 4hh Replace controller
Clam not latching in closed position.	5a Program not selected. 5b Program time insufficient to allow latching. 5c Check micro switch function (normally open). 5d Check rectifier – input & output. 5e Check DC magnet for closure to striker plate.  <b>If Magnetic type</b> 5f Check magnet is magnetising.	5aa Select a program. 5bb Adjust program time. 5cc Press and release switch – check for correct action. 5dd Replace if faulty. 5ee Adjust as necessary.  5ff Replace as necessary.

Faultfinder (Continued 3.)

<b>Problem</b>	<b>Possible cause</b>	<b>Solution</b>
Clam not latching in closed position.	<p><b>If Latch type</b></p> <p>5g Check latch.</p>	<p>Check that clam is closing parallel to griddle plate - correct if necessary.</p> <p>Check solenoid function and also that DC power supply is ok, correct as necessary.</p> <p>Check split pins for wear/damage – replace if necessary.</p>
Clam heats up, (clam only, bottom griddle off), with alarm tone. Controller reading 'BOTTOM PRB / TOP LOW'	<p>6a Check for breaks/bad plug/socket pin connections.</p> <p>6b Probe failure.</p> <p>Repeat procedure for Clam fault.</p>	<p>6aa Correct as necessary</p> <p>6bb Replace probe.</p>
Machine runs, but switches off.	<p>7a Allow to heat up and cut out, when warm check top &amp; bottom bi-metallic.</p>	<p>7aa Check for 24V is continuous</p> <p>Check top and bottom bi-metallic switches, replace as necessary.</p>

## Spare Parts Listing

PART NO.	PART NAME	No. Req.	
MF CGCE	Clam Griddle Clam Element 1500W Elements	3	
MF CGGE	Clam Griddle Element 1500W Elements	3	
MFCGGASSTRUT	590N Gas Struts With Fork Ends & Ball Joints	2	
MF TDN135	Gas Strut Eye End	2	
MF VC-13	'Non-stick' sheet clip retainer	4	
MF CGCONTROLLER	Fastron Controller	1	
MFE5611742050	250°C Griddle Plate Hi-limit thermostat	1	
MF CLAMPROBE	Fastron Controller Probe	2	
MF 454-7761	4 Pole No Coil Contactor, 20A 24Vac Coil	3	

MF 539-8380	Type C MCB 3 Pole 6KA 40A Breaker	1	
MF 342-2605	Double Headed Pushbutton Switch 24v ac/dc	2	
MF 193-026	BRIDGE RECTIFIER QUAD SKB25/02 17A 200V	1	
MF 508-3533	SPDT Din Rail Realy 6A, 24VAC/DC Coil	3	
MF 504-672	50 (VA) 203 Primary 2X12V Secondary Transformer	1	
MF 374-1029	10mm Low Profile Lens LED Indicator, 230V AC	3	
MF 456-4659	4CRQR Snap Action Micro Switch	1	
MF 339-8394	3/4" Pedestal Bearing (Pillow Block Bearing)	2	
MF 227-019	Male Straight Adaptor 1/8" BSP TO 3/16" (With Olive & Nut)	2	
MF 537-1004	Anti Surge T LBC Min Fuse, 10A 6.3mm x 32mm	1	
MF 537-1688	Anti Surge T LBC Min Fuse, 1.25A 6.3mm x 32mm	2	

MF843-520	415V 16A 3P+N+E TYPE 210 STRAIGHT PLUG	2	
MF723-2391	415V 16A 3P+N+E TYPE 110 SURFACE INLET	1	
MF 515-723	Limit micro handle switch	1	
MF 472-8285	Sealed sub miniature micro switch	1	
MF CLAMMAGNET	3-58-0602-Z2002 24V Electromagnet & Armature (1400N), Fly Leads	1	
MF 5377PJP100P50	Castors with brake	2	
MF 5370PJP100P50	Castors without brake	2	
MF CG450STICKER	Controller Sticker	1	
MFCGANTISURGE	DNRIOUS25/1550977 ANTI SURGE PROTECTION	1	

SS CL116X49	Non stick Sheet	2	
EQ PC233-71A	Rubber Wiper	1	
EQ PC161	Scraper	1	
NC XXCEPI	Wire Brush	1	
EQ PC367B	Burger Turner	1	
FF 65TOOLCLIP	Tool Clip Fitted To All To All Clam Grills	1	





# Clam platen assembly (machines 1-30)

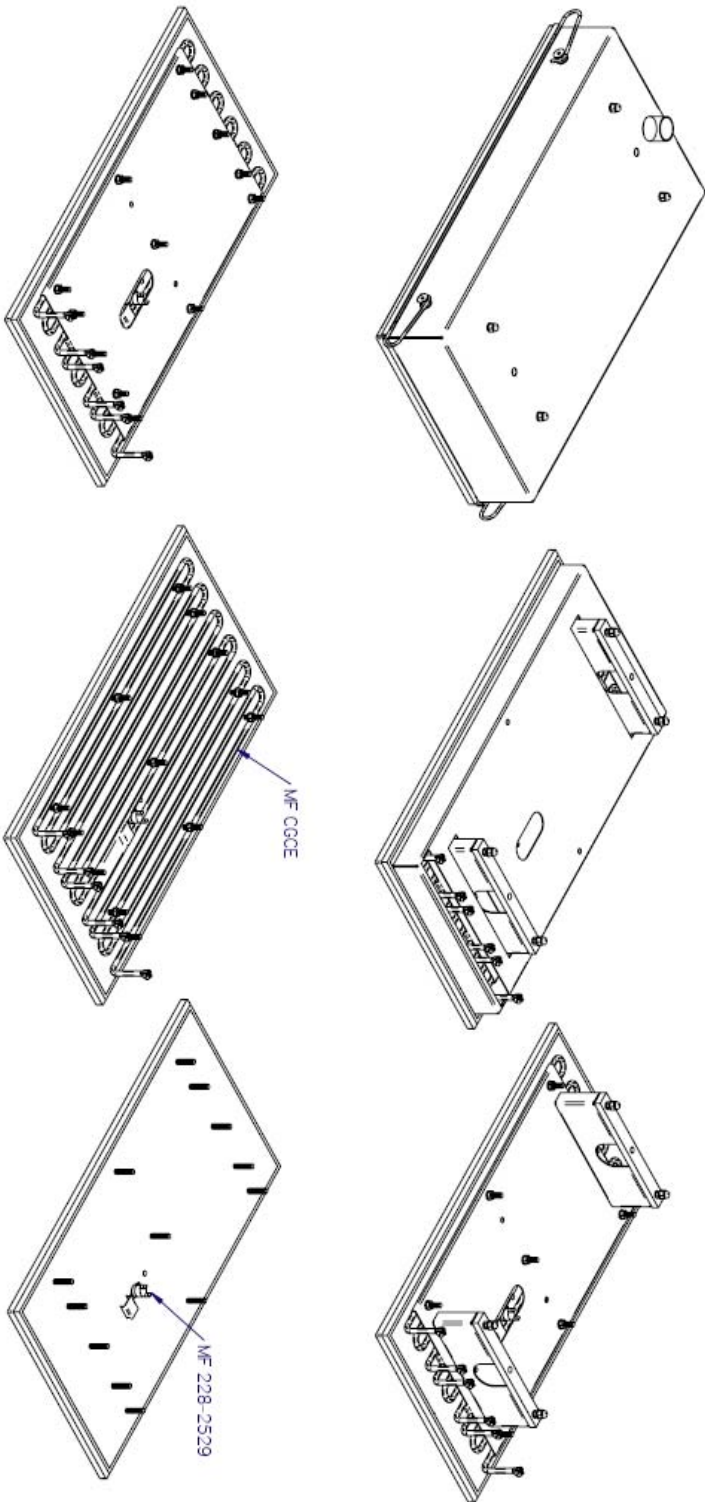

PARTS LIST		PARTS NAME		QTY	UNIT	REVISION
1	BRACKET	BRACKET	BRACKET	1	EA	1
2	CLAMP	CLAMP	CLAMP	1	EA	1
3	ROD	ROD	ROD	1	EA	1
4	WASHER	WASHER	WASHER	1	EA	1
5	NUT	NUT	NUT	1	EA	1
6	SCREW	SCREW	SCREW	1	EA	1
7	PLATE	PLATE	PLATE	1	EA	1
8	PLATE	PLATE	PLATE	1	EA	1
9	ROD	ROD	ROD	1	EA	1
10	WASHER	WASHER	WASHER	1	EA	1
11	NUT	NUT	NUT	1	EA	1
12	SCREW	SCREW	SCREW	1	EA	1
13	PLATE	PLATE	PLATE	1	EA	1
14	PLATE	PLATE	PLATE	1	EA	1
15	ROD	ROD	ROD	1	EA	1
16	WASHER	WASHER	WASHER	1	EA	1
17	NUT	NUT	NUT	1	EA	1
18	SCREW	SCREW	SCREW	1	EA	1
19	PLATE	PLATE	PLATE	1	EA	1
20	PLATE	PLATE	PLATE	1	EA	1
21	ROD	ROD	ROD	1	EA	1
22	WASHER	WASHER	WASHER	1	EA	1
23	NUT	NUT	NUT	1	EA	1
24	SCREW	SCREW	SCREW	1	EA	1
25	PLATE	PLATE	PLATE	1	EA	1
26	PLATE	PLATE	PLATE	1	EA	1
27	ROD	ROD	ROD	1	EA	1
28	WASHER	WASHER	WASHER	1	EA	1
29	NUT	NUT	NUT	1	EA	1
30	SCREW	SCREW	SCREW	1	EA	1
31	PLATE	PLATE	PLATE	1	EA	1
32	PLATE	PLATE	PLATE	1	EA	1
33	ROD	ROD	ROD	1	EA	1
34	WASHER	WASHER	WASHER	1	EA	1
35	NUT	NUT	NUT	1	EA	1
36	SCREW	SCREW	SCREW	1	EA	1
37	PLATE	PLATE	PLATE	1	EA	1
38	PLATE	PLATE	PLATE	1	EA	1
39	ROD	ROD	ROD	1	EA	1
40	WASHER	WASHER	WASHER	1	EA	1
41	NUT	NUT	NUT	1	EA	1
42	SCREW	SCREW	SCREW	1	EA	1
43	PLATE	PLATE	PLATE	1	EA	1
44	PLATE	PLATE	PLATE	1	EA	1
45	ROD	ROD	ROD	1	EA	1
46	WASHER	WASHER	WASHER	1	EA	1
47	NUT	NUT	NUT	1	EA	1
48	SCREW	SCREW	SCREW	1	EA	1
49	PLATE	PLATE	PLATE	1	EA	1
50	PLATE	PLATE	PLATE	1	EA	1
51	ROD	ROD	ROD	1	EA	1
52	WASHER	WASHER	WASHER	1	EA	1
53	NUT	NUT	NUT	1	EA	1
54	SCREW	SCREW	SCREW	1	EA	1
55	PLATE	PLATE	PLATE	1	EA	1
56	PLATE	PLATE	PLATE	1	EA	1
57	ROD	ROD	ROD	1	EA	1
58	WASHER	WASHER	WASHER	1	EA	1
59	NUT	NUT	NUT	1	EA	1
60	SCREW	SCREW	SCREW	1	EA	1
61	PLATE	PLATE	PLATE	1	EA	1
62	PLATE	PLATE	PLATE	1	EA	1
63	ROD	ROD	ROD	1	EA	1
64	WASHER	WASHER	WASHER	1	EA	1
65	NUT	NUT	NUT	1	EA	1
66	SCREW	SCREW	SCREW	1	EA	1
67	PLATE	PLATE	PLATE	1	EA	1
68	PLATE	PLATE	PLATE	1	EA	1
69	ROD	ROD	ROD	1	EA	1
70	WASHER	WASHER	WASHER	1	EA	1
71	NUT	NUT	NUT	1	EA	1
72	SCREW	SCREW	SCREW	1	EA	1
73	PLATE	PLATE	PLATE	1	EA	1
74	PLATE	PLATE	PLATE	1	EA	1
75	ROD	ROD	ROD	1	EA	1
76	WASHER	WASHER	WASHER	1	EA	1
77	NUT	NUT	NUT	1	EA	1
78	SCREW	SCREW	SCREW	1	EA	1
79	PLATE	PLATE	PLATE	1	EA	1
80	PLATE	PLATE	PLATE	1	EA	1
81	ROD	ROD	ROD	1	EA	1
82	WASHER	WASHER	WASHER	1	EA	1
83	NUT	NUT	NUT	1	EA	1
84	SCREW	SCREW	SCREW	1	EA	1
85	PLATE	PLATE	PLATE	1	EA	1
86	PLATE	PLATE	PLATE	1	EA	1
87	ROD	ROD	ROD	1	EA	1
88	WASHER	WASHER	WASHER	1	EA	1
89	NUT	NUT	NUT	1	EA	1
90	SCREW	SCREW	SCREW	1	EA	1
91	PLATE	PLATE	PLATE	1	EA	1
92	PLATE	PLATE	PLATE	1	EA	1
93	ROD	ROD	ROD	1	EA	1
94	WASHER	WASHER	WASHER	1	EA	1
95	NUT	NUT	NUT	1	EA	1
96	SCREW	SCREW	SCREW	1	EA	1
97	PLATE	PLATE	PLATE	1	EA	1
98	PLATE	PLATE	PLATE	1	EA	1
99	ROD	ROD	ROD	1	EA	1
100	WASHER	WASHER	WASHER	1	EA	1
101	NUT	NUT	NUT	1	EA	1
102	SCREW	SCREW	SCREW	1	EA	1
103	PLATE	PLATE	PLATE	1	EA	1
104	PLATE	PLATE	PLATE	1	EA	1
105	ROD	ROD	ROD	1	EA	1
106	WASHER	WASHER	WASHER	1	EA	1
107	NUT	NUT	NUT	1	EA	1
108	SCREW	SCREW	SCREW	1	EA	1
109	PLATE	PLATE	PLATE	1	EA	1
110	PLATE	PLATE	PLATE	1	EA	1
111	ROD	ROD	ROD	1	EA	1
112	WASHER	WASHER	WASHER	1	EA	1
113	NUT	NUT	NUT	1	EA	1
114	SCREW	SCREW	SCREW	1	EA	1
115	PLATE	PLATE	PLATE	1	EA	1
116	PLATE	PLATE	PLATE	1	EA	1
117	ROD	ROD	ROD	1	EA	1
118	WASHER	WASHER	WASHER	1	EA	1
119	NUT	NUT	NUT	1	EA	1
120	SCREW	SCREW	SCREW	1	EA	1
121	PLATE	PLATE	PLATE	1	EA	1
122	PLATE	PLATE	PLATE	1	EA	1
123	ROD	ROD	ROD	1	EA	1
124	WASHER	WASHER	WASHER	1	EA	1
125	NUT	NUT	NUT	1	EA	1
126	SCREW	SCREW	SCREW	1	EA	1
127	PLATE	PLATE	PLATE	1	EA	1
128	PLATE	PLATE	PLATE	1	EA	1
129	ROD	ROD	ROD	1	EA	1
130	WASHER	WASHER	WASHER	1	EA	1
131	NUT	NUT	NUT	1	EA	1
132	SCREW	SCREW	SCREW	1	EA	1
133	PLATE	PLATE	PLATE	1	EA	1
134	PLATE	PLATE	PLATE	1	EA	1
135	ROD	ROD	ROD	1	EA	1
136	WASHER	WASHER	WASHER	1	EA	1
137	NUT	NUT	NUT	1	EA	1
138	SCREW	SCREW	SCREW	1	EA	1
139	PLATE	PLATE	PLATE	1	EA	1
140	PLATE	PLATE	PLATE	1	EA	1
141	ROD	ROD	ROD	1	EA	1
142	WASHER	WASHER	WASHER	1	EA	1
143	NUT	NUT	NUT	1	EA	1
144	SCREW	SCREW	SCREW	1	EA	1
145	PLATE	PLATE	PLATE	1	EA	1
146	PLATE	PLATE	PLATE	1	EA	1
147	ROD	ROD	ROD	1	EA	1
148	WASHER	WASHER	WASHER	1	EA	1
149	NUT	NUT	NUT	1	EA	1
150	SCREW	SCREW	SCREW	1	EA	1
151	PLATE	PLATE	PLATE	1	EA	1
152	PLATE	PLATE	PLATE	1	EA	1
153	ROD	ROD	ROD	1	EA	1
154	WASHER	WASHER	WASHER	1	EA	1
155	NUT	NUT	NUT	1	EA	1
156	SCREW	SCREW	SCREW	1	EA	1
157	PLATE	PLATE	PLATE	1	EA	1
158	PLATE	PLATE	PLATE	1	EA	1
159	ROD	ROD	ROD	1	EA	1
160	WASHER	WASHER	WASHER	1	EA	1
161	NUT	NUT	NUT	1	EA	1
162	SCREW	SCREW	SCREW	1	EA	1
163	PLATE	PLATE	PLATE	1	EA	1
164	PLATE	PLATE	PLATE	1	EA	1
165	ROD	ROD	ROD	1	EA	1
166	WASHER	WASHER	WASHER	1	EA	1
167	NUT	NUT	NUT	1	EA	1
168	SCREW	SCREW	SCREW	1	EA	1
169	PLATE	PLATE	PLATE	1	EA	1
170	PLATE	PLATE	PLATE	1	EA	1
171	ROD	ROD	ROD	1	EA	1
172	WASHER	WASHER	WASHER	1	EA	1
173	NUT	NUT	NUT	1	EA	1
174	SCREW	SCREW	SCREW	1	EA	1
175	PLATE	PLATE	PLATE	1	EA	1
176	PLATE	PLATE	PLATE	1	EA	1
177	ROD	ROD	ROD	1	EA	1
178	WASHER	WASHER	WASHER	1	EA	1
179	NUT	NUT	NUT	1	EA	1
180	SCREW	SCREW	SCREW	1	EA	1
181	PLATE	PLATE	PLATE	1	EA	1
182	PLATE	PLATE	PLATE	1	EA	1
183	ROD	ROD	ROD	1	EA	1
184	WASHER	WASHER	WASHER	1	EA	1
185	NUT	NUT	NUT	1	EA	1
186	SCREW	SCREW	SCREW	1	EA	1
187	PLATE	PLATE	PLATE	1	EA	1
188	PLATE	PLATE	PLATE	1	EA	1
189	ROD	ROD	ROD	1	EA	1
190	WASHER	WASHER	WASHER	1	EA	1
191	NUT	NUT	NUT	1	EA	1
192	SCREW	SCREW	SCREW	1	EA	1
193	PLATE	PLATE	PLATE	1	EA	1
194	PLATE	PLATE	PLATE	1	EA	1
195	ROD	ROD	ROD	1	EA	1
196	WASHER	WASHER	WASHER	1	EA	1
197	NUT	NUT	NUT	1	EA	1
198	SCREW	SCREW	SCREW	1	EA	1
199	PLATE	PLATE	PLATE	1	EA	1
200						

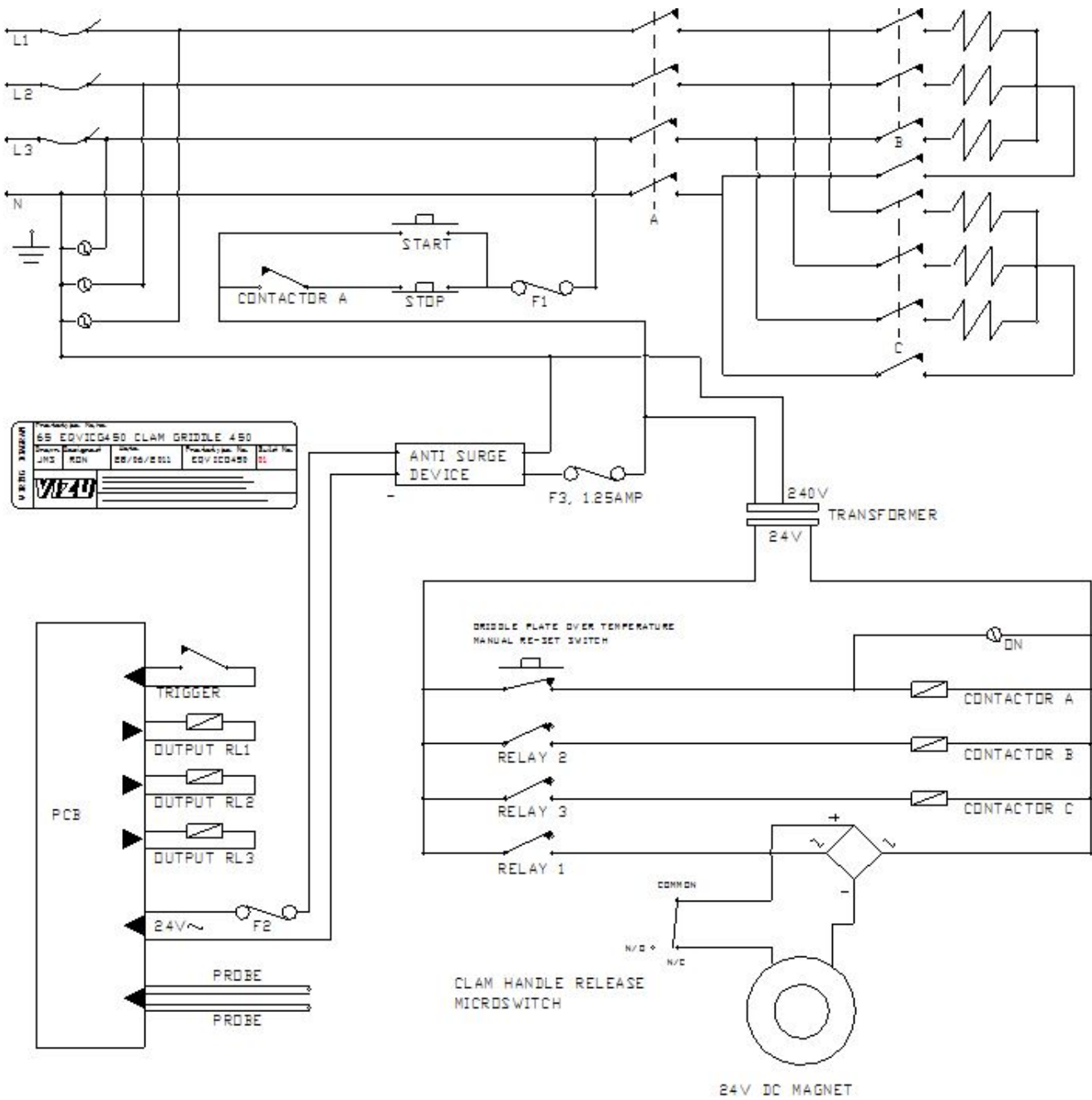

MAGNETIC TYPE WITH HANDLE SWITCH (no bi-metallics)

## HANDLE SWITCH WITH ANTI SURGE

Damage claim form

Machine: **CLAM GRIDDLE**

Product code: **EQVI450CG**

Customer name.....

Date of delivery.....

Machine serial number.....

Damage comments.....

.....  
.....  
.....  
.....

Please indicate on the picture where the unit is damaged

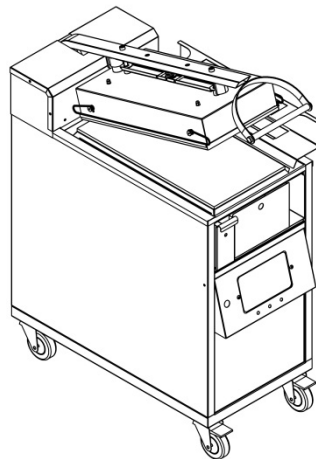

Courier name.....

Please cut this page out and post to **Fast Food Systems**  
(The address is on the back of this manual)

# Terms and Conditions

## **Claims**

No claim shall be entertained by the Company unless made in writing. Claims arising from damage or partial loss in transit must reach the Company within 7 days from the date of delivery. Claims for non-delivery must reach the Company within 10 days from the date of dispatch. All other claims must reach the Company within 7 days. Damaged goods must be retained for inspection/collection.

## **Returns**

The Company does not operate a returns policy unless the goods are defective:

In circumstances where the Company agrees to accept return of goods, a charge of 25% of the invoice value will be made.

## Warranty

### *UNITED KINGDOM AND REPUBLIC OF IRELAND*

Excepting where otherwise specified all products are subject to 12 months parts and labour warranty Goods found defective will be repaired, credited or replaced without charge according to the terms of the Company's standard warranty, provided written notice is given within the guarantee period. In no case will the company be liable for repairs made without it's knowledge or sanction, or for indirect damage, or any consequential loss or expense incurred by purchasers.

Fast Food Systems Ltd, warrants to the original purchaser that the equipment supplied to be free from defective materials or workmanship for a period of 12 (twelve) months.

The following are NOT covered by warranty:

1. Failure or breakdown caused by incorrect installation.
2. Glass parts, electric lamps or door seals.
3. Adjustment or calibration of controls - this is a routine maintenance function.
4. Abuse or misuse, including cleaning.
5. Warranty labour is only carried out during normal working hours, calls attended to out of hours may be subject to surcharges.
6. The warranty will commence either on installation or 1 (one) month from date of dispatch - whichever is the sooner.
7. Warranty on spare parts purchased for equipment outside of the warranty period is 3 (three) months from date of sale.
8. Any faulty spare parts replaced under warranty must be returned with 7 days of supply.
9. Warranty is non-transferable.

***Fast-Food-Systems Ltd*** will not be held responsible, financially or otherwise, for any loss of business as a result of equipment breakdown.

Model Number.....

Order ID/Job No.....

Machine serial number.....

Date of Manufacture ...../...../.....

Date of delivery...../...../.....

Date of commissioning...../...../.....



**ENGLISH**

Electrical equipment marked with this symbol may not be disposed of in European public disposal systems after 12 August 2005. In conformity with European local and national regulations (EU Directive 2002/96/EC), European electrical equipment users must now return old or end-of-life equipment to the manufacturer for disposal at no charge to the user.

**Note:** For return for recycling, please contact the equipment manufacturer or supplier for instructions on how to return end-of-life equipment for proper disposal.

**Fast Food Systems Limited**

Manufacturer & Distributor of Catering Equipment

Unit 1 Headley Park 9 Headley Road East

Woodley Reading Berkshire RG5 4SQ

Tel: 0118 944 1100 Fax: 0118 944 0350

Email: [service@fast-food-systems.co.uk](mailto:service@fast-food-systems.co.uk)

Website: [www.fast-food-systems.com](http://www.fast-food-systems.com)

ISSUE: 10/SEPTEMBER/2013