

Vizu Auto Breader

EQVI005AB



- Vizu mobile breadering station with motorised rotary sieve, for dividing re-usable flour & dough balls for discarding.

AUTO BREADER SPECIFICATION PAGE

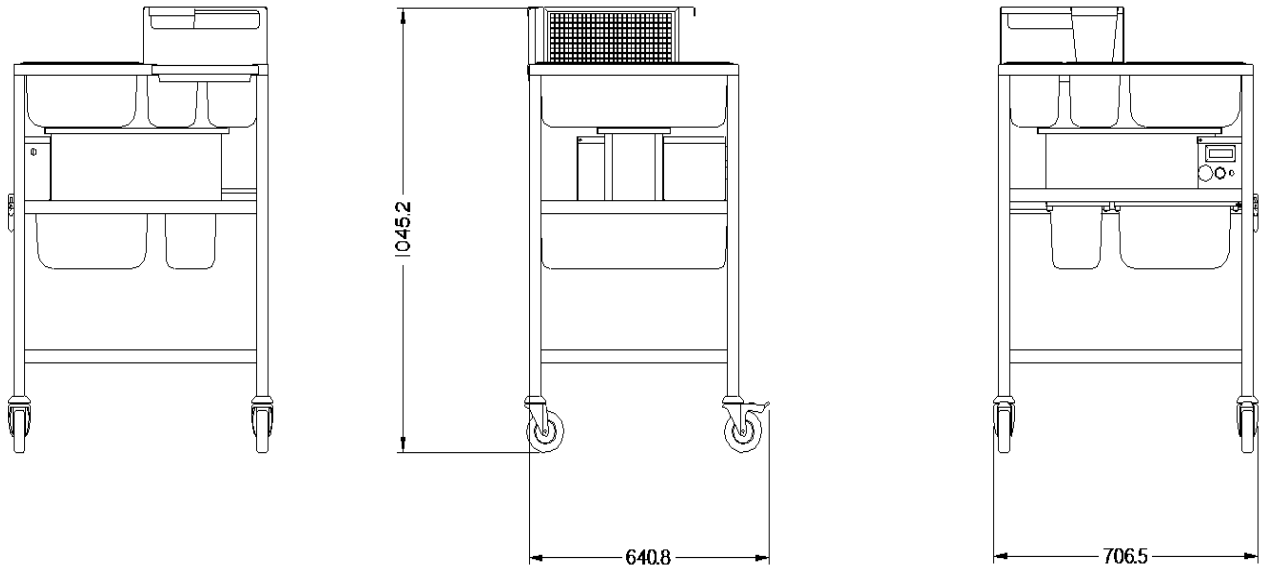

MODEL EQVI005AB

| | |
|----------------------|---------------------------------|
| Dimensions | Machine |
| Height | 1045mm |
| Width | 710mm |
| Depth | 645mm |
| Weight | 43kg |
| Electrical | 1 phase , 50Hz AC, 230 V, .01kw |
| Running Amps | |
| Connection Type | BESCHUKO Power cord |
| International Option | N/A |

All Vizu Auto Breaders have been tested and checked for proper operation before leaving the factory.

Upon delivery please check the unit for damage. If the unit is damaged, contact the carrier, or Fast Food Systems, immediately and file a damage claim (found in the back of the manual). Please retain all packing materials.

Damage must be reported within 7 days of delivery

General Description

The Vizu mobile breading station is a motorised rotary sieve used for dividing re-usable flour & dough balls.

Assembly Instructions

1. Remove all packaging.
2. Remove any protective plastic covering from panels.
3. Wash all removable items in warm soapy water.
4. Wipe all surfaces with proprietary stainless steel cleaner, or a warm damp cloth.
5. Dry all items thoroughly.

Installation

Position the Auto Breader in desired position, close to a suitable electrical supply, lock wheels in position and connect to supply. The unit is supplied with a 13 amp, 3-pin UK plug, fitted with a 5amp fuse.

Operating Instructions (EQVI005AB)

1. Remove steel plug from large pan.
2. Using the steel plug push the breadding through the hole onto the sieve.
3. Once the sieve compartment is full – or you have added enough breadding for your requirements replace the stainless steel plug.
4. Press the 'red' ON/OFF emergency stop button. The countdown timer will now be illuminated showing the factory pre-set of 15 seconds. If this display is not illuminated check that the machine is plugged in and wall switch is on.
5. Make sure the tray and ½ trays are in position on the slides under the shelf of the machine.
6. Press the 'green' switch and the machine will run. (FIG.1)



Figure 1: Green button to turn on machine.

DO NOT LIFT PLUG OUT AS BREADING WILL BE FLICKED OUT WHICH IS POTENTIALLY DANGEROUS

7. If the machine needs to be stopped press the 'red' ON / OFF emergency stop button. This will stop the machine. It will be switched off and display will not be illuminated.



8. To resume operation the 'red' button will need to be pulled out to switch the machine back on.
9. Repeat step 6
10. Once the machine has run through its program, the display will re-set to its start time of 15 seconds. If the machine is required again, repeat step 1 – 9 otherwise presses the 'red' button to switch OFF.
11. The sieved breading will now be in the bottom tray – ready for use.

Note: - Due to the double action of the 'Red' push button care must be taken to only push once when stopping the machine, to avoid re-energising of the unit.

Cleaning (EQVI005AB)

- Disconnect from power supply.
- Remove the stainless steel pans and wash in warm soapy water, dry thoroughly with a soft dry cloth.



- Remove both pan supports from the Breeder frame
- Lift the lid off the sieve

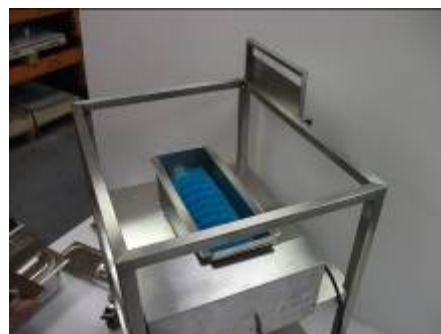

- Unlatch the drop catch on the side of the motor box and slide the motor box over 2 to 3 inches. This disengages the motor.



- Holding the breading compartment the brush can now be slid back in the direction of the drive side – removing the end of the shaft from the bearing on the breading compartment.



- The brush can now be lifted out.



Once all the parts have been removed they must be washed in warm soapy water to remove all traces of flour and breading mix.

The machine should NOT be re-assembled until all the parts have been thoroughly dried. Follow steps 1 – 8 in reverse order.

WIRING DIAGRAM

| | | | |
|---|----------|-----------------|---------------------------|
| Prototype Name | | 61 AUTO BREADER | |
| Drawn | Designed | Date | Prototype No. / Build No. |
| JMS | RT | 14/03/2012 | EQV1005AB / 03 |
| VIZU | | | |
| Property of Fast Food Systems Ltd. May not be reproduced or used in any manner whatsoever without written permission. | | | |
| Unit 1, Headley Park 9, Headley Road East Woodley, Reading RG5 4SQ | | | |

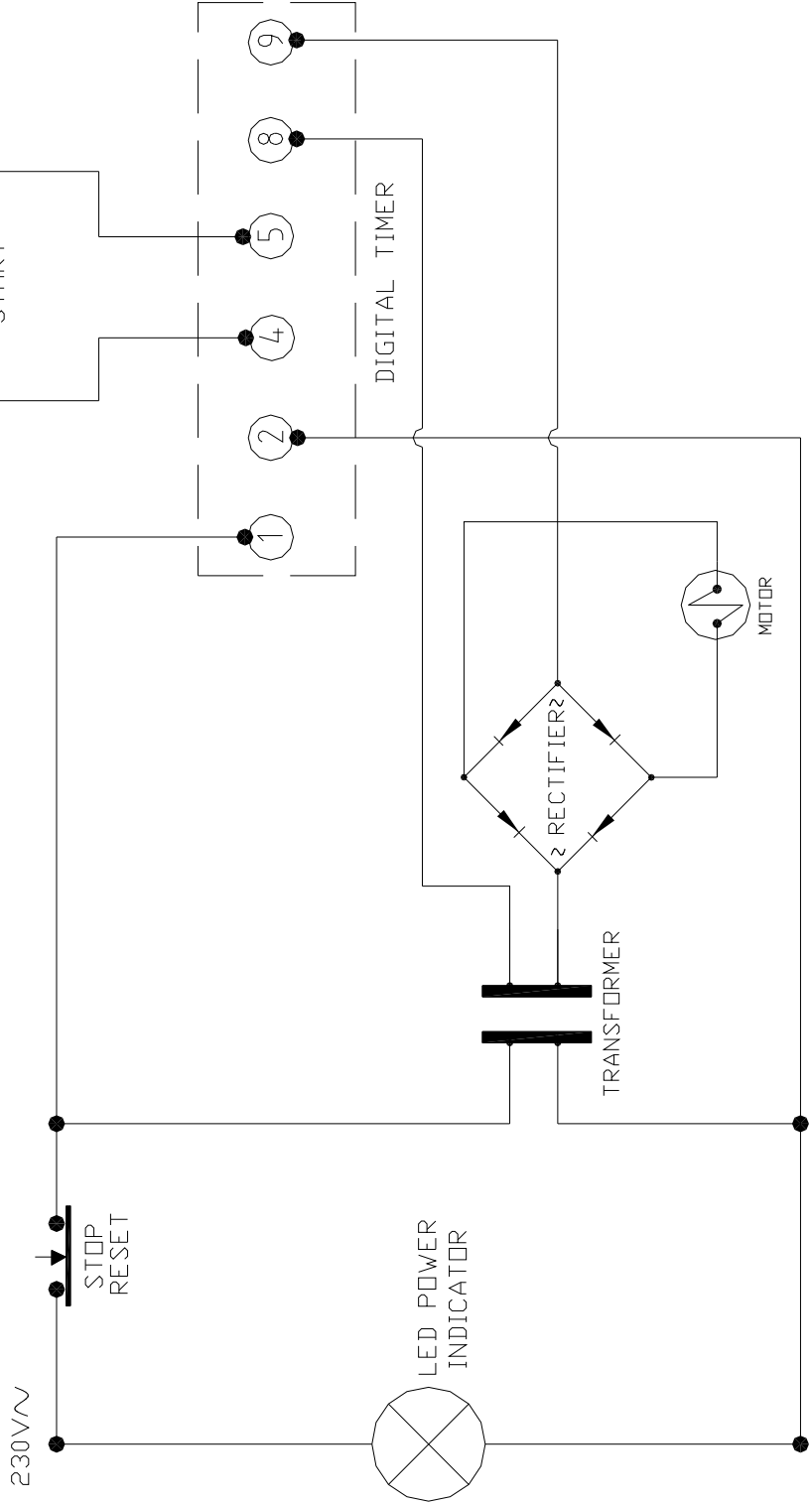

Spare Parts List

| Part No. | Description | Qty | |
|------------------|------------------------------------|-----|---|
| MF PLCASTOR | Tube fixing swivel castor | 2 |  |
| MF PLCASTORB | Tube fixing swivel castor (braked) | 2 |  |
| MF 8168-224 | Thumb screw | 10 |  |
| MF 02-2550/61-28 | Brush | 1 |  |
| EQ TR1721 | But Mil Bin | 4 | |
| MF 005ABMOTOR | Motor | 1 |  |
| MF 318-985 | Red Emergency Stop Switch and Body | 1 |  |
| MF 318-856 | Green Switch | 1 |  |
| MF 193-026 | Rectifier | 1 |  |
| MF315500/1F13UK | Plug and lead | 1 | |
| MF TIMER | Digital Count Down Timer | 1 |  |
| MF 354Z | Ceramic Block | 1 |  |
| MF 504-341 | 230V – 24V Transformer | 1 |  |
| Mf BREADSEAL | Breader Compartment seal | 1 |  |

Fault Finding

Qualified personnel must only carry out any servicing.

Machine must be removed from electrical supply before any servicing.

izu Auto Breader EQVI005AB

| Problem | Probable Cause | Solution |
|---|--|--|
| 1. Count down timer will not illuminate. | <ul style="list-style-type: none"> • Not plugged in • Not switch 'ON' at plug. | <ul style="list-style-type: none"> • Check machine switch is 'ON'. • Check wall switch is 'ON' • Press Emergency Stop to reset |
| 2. Breader does not function. | <ul style="list-style-type: none"> • Emergency switch accidentally pressed. • Defective 'ON / OFF' switch. • Fuse in plug faulty • Loose / broken connection. | <ul style="list-style-type: none"> • Check external currant breaker is 'ON/IN' at main supply board. • Check fuse in 3 pin plug • Check all connections • Tighten or replace switch connectors or wiring. • Replace switch • Replace motor |
| 3. Count down timer illuminated-motor does not work | <ul style="list-style-type: none"> • Start switch disconnected. • Start switch faulty/broken. • Transformer/rectifier broken or disconnected • Motor burnt out | <ul style="list-style-type: none"> • Check connections on reset switch. • Replace switch. • Check connections on rectifier& transformer • Replace motor |

Terms and Conditions

Claims

No claim shall be entertained by the Company unless made in writing. Claims arising from damage or partial loss in transit must reach the Company within 7 days from the date of delivery. Claims for non-delivery must reach the Company within 10 days from the date of dispatch. All other claims must reach the Company within 7 days. Damaged goods must be retained for inspection/collection.

Returns

The Company does not operate a returns policy unless the goods are defective:

In circumstances where the Company agrees to accept return of goods, a charge of 25% of the invoice value will be made.

DAMAGE CLAIM FORM

Machine: Vizu Auto Breader

Product code: EQV1005AB

Customer name.....

Date of delivery.....

Machine serial number.....

Damage comments.....

.....

.....

.....

.....

.....

.....

.....

.....

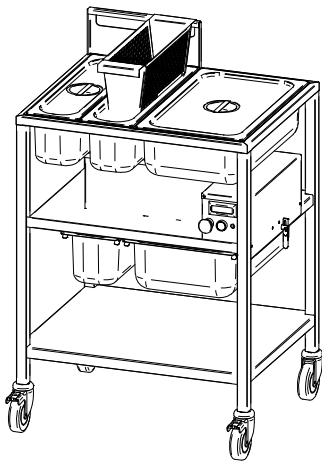

Please indicate on the picture where the unit is damaged

Courier name.....

Please cut this page out and post to *Fast Food Systems*

(The address is on the back of this manual)

Warranty

UNITED KINGDOM AND REPUBLIC OF IRELAND

Excepting where otherwise specified all products are subject to 12 months parts and labour warranty. Goods found defective will be repaired, credited or replaced without charge according to the terms of the Company's standard warranty, provided written notice is given within the guarantee period. In no case will the company be liable for repairs made without its knowledge or sanction, or for indirect damage, or any consequential loss or expense incurred by purchasers.

Fast Food Systems Ltd, warrants to the original purchaser that the equipment supplied to be free from defective materials or workmanship for a period of 12 (twelve) months.

The following are NOT covered by warranty:

1. Failure or breakdown caused by incorrect installation.
2. Glass parts, electric lamps or door seals.
3. Adjustment or calibration of controls - this is a routine maintenance function.
4. Abuse or misuse, including cleaning.
5. Warranty labour is only carried out during normal working hours; calls attended to out of hours may be subject to surcharges.
6. The warranty will commence either on installation or 1 (one) month from date of dispatch - whichever is the sooner.
7. Warranty on spare parts purchased for equipment outside of the warranty period is 3 (three) months from date of sale.
8. Any faulty spare parts replaced under warranty must be returned with 7 days of supply.
9. Warranty is non-transferable.

Fast-Food-Systems Ltd will not be held responsible, financially or otherwise, for any loss of business as a result of equipment breakdown.

Model Number.....

Order ID/Job No.....

Machine serial number.....

Date of Manufacture/...../.....

Date of delivery...../...../.....

Date of commissioning...../...../.....

| | |
|---|---|
|  | <p>ENGLISH</p> <p>Electrical equipment marked with this symbol may not be disposed of in European public disposal systems after 12 August 2005. In conformity with European local and national regulations (EU Directive 2002/96/EC), European electrical equipment users must now return old or end-of-life equipment to the manufacturer for disposal at no charge to the user.</p> <p>Note: For return for recycling, please contact the equipment manufacturer or supplier for instructions on how to return end-of-life equipment for proper disposal.</p> |
|---|---|

Fast Food Systems Limited

Manufacturer & Distributor of Catering Equipment

Unit 1 Headley Park 9 Headley Road East

Woodley Reading Berkshire RG5 4SQ

Tel: 0118 944 1100 Fax: 0118 944 0350

Email: service@fast-food-systems.co.uk

Website: www.fast-food-systems.com

ISSUE: 06/MAY2013