

Gastro Warmer

EQVIGWCOMP



- Ideal for keeping cooked food at controlled temperature.
- Precision digital temperature control
- Countdown timer and alarm
- Drawer holds 1 1/1 GN pan 150mm deep (Supplied).

Gastro Warmer Specification Page



Model EQVIGWCOMP

Dimensions	Machine
Height	370mm
Width	605mm
Depth	505mm
Weight	30kg
Electrical	1 phase, 50HZ AC, 0.600Kw, 230V
Running Amps	2.6 Amps
Connection Type	BSCHUKO 2/3 PIN PLUG
International Option	N/A

All **Vizu Gastro Warmers** have been tested and checked for proper operation before leaving the Fast Food Systems manufacturing facility.

Upon delivery please check the unit for damage. If the unit is damaged, contact the carrier, or Fast Food Systems, immediately and file a damage claim (found in the back of the manual) Please retain all packing materials.

Damage must be reported within 7 days of delivery

General Description

The unit has been designed for the short term holding of cooked product, at a controlled temperature

Assembly Instructions

1. Remove all packaging material from the Gastro Warmer unit.
2. Peel off all protective plastic covering from metal.
3. Wash all removable parts in warm, soapy water and dry them thoroughly.

Installation

Check that the power rocker switch located on the front control panel is set to the OFF position.

Position the Vizu Gastro Warmer unit in the desired position and ensure all four corners of the unit are making contact with surface and the unit is stable and secure.

Connect the unit to power supply.

Operating Instructions

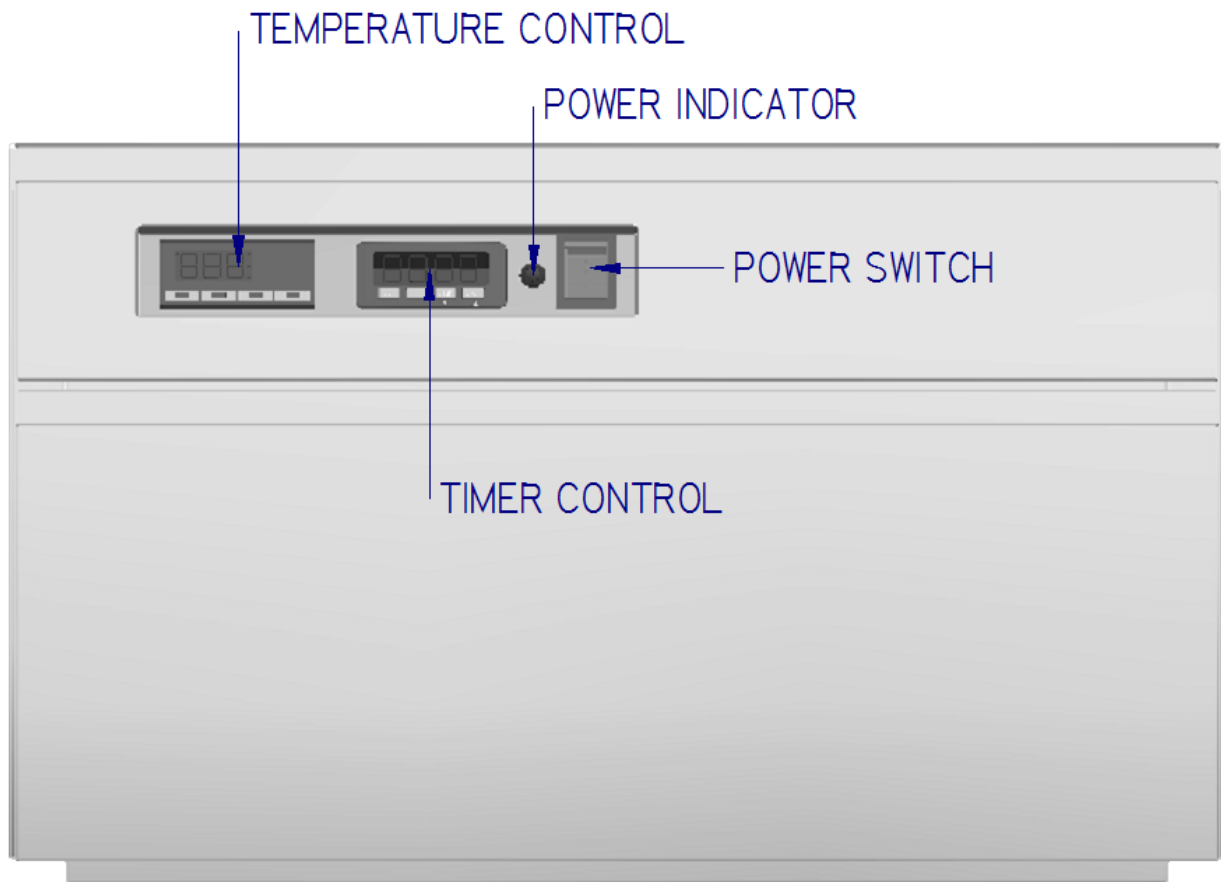

FRONT

1. Plug in and switch 'ON' at wall socket.
2. Red LED power indicator indicates machine is connected to the power supply.
3. Red Rocker switch allows power to pass to heating elements (the temperature is controlled by the digital thermostat). Select position (ON).
4. Digital controller will display start symbols then current temperature and start to heat up, it will take 30 minutes to reach temperature.
5. The controller is set factory set at 70°C.

Note: - If using factory settings it is not advisable to use 150mm deep polycarbonate dishes as the temperature inside the unit may cause damage

Temperature Control

The Gastro Warmer has been factory set at 70°C with an operating range 65 - 75°C.

To vary factory set temperatures:

1. With the machine switched 'ON' i.e. in the working condition press 'SET'. The set control temperature with a flashing LED will be displayed on the digital thermostat display.
2. While the LED is flashing use the up or down arrows to raise or lower to the required operating temperature within parameters (65 - 75°C).
3. When required temperature is displayed press SET to put this temperature into the control programme.

Countdown Timer

A countdown timer is fitted to the machine for timing the products hold time. This counter can be set to operate from 00.01 sec to 99 min 59 sec.

To reset time

1. Switch the machine on. Both the heating and timer control units will flash. Once they have both stopped flashing, press the "set" button and either the ▲ or ▼ to increase or decrease the required timing setting (minutes).
2. To start a countdown period, press the "Start" button (▲) and to stop the timer press the "Stop" button (▼).

Cleaning instructions

1. SWITCH 'OFF' and remove electrical cord from wall supply. Allow unit to cool.
2. Remove pan. Wash in hot soapy water, rinse and dry.
3. Wipe all external surfaces with proprietary stainless steel cleaner or warm damp cloth – dry thoroughly.
4. Replace pan.

DO NOT USE ANY ABRASIVE MATERIALS, SCOURING PADS AND DO NOT USE BLEACH.

Spare Parts List

PART NO	DESCRIPTION	QTY	
MF MTR11TIRES	Digital Thermostat	1	
MF TIMER	Digital Count Down Timer	1	
VI SW17	Red Rocker Switch	1	
VI LE14	Rocker Switch Cover	1	
MF 374-1029	10mm LED Power Indicator	1	
MF EUROCONVERT	Euro to UK plug conversion	1	
376-925	Relay 65-31	1	

MF P08	Element (500W)	2	
MF S561016	16" Drawer Slides	1 pair	
GS GAST40062	150mm Gastronome Pan	1	
GS GAST160	Stainless Steel Wire Tray Insert	1	
MF 120-6594	Six Tab Neutral Terminal Block	1	
MF 121-1488	Six Tab Neutral Terminal Block	2	

Fault Finding

Any servicing must only be carried out by qualified personnel. Machine must be removed from electrical supply before any servicing.

PROBLEM	POSSIBLE CAUSE	SOLUTION
1. Red LED Power indicator is not illuminated.	<ul style="list-style-type: none"> ⇒ Wall socket switched OFF. ⇒ Fuse in plug faulty. ⇒ Power supply failed. 	<ul style="list-style-type: none"> • Switch ON. • Replace fuse. • Check power supply
2. Red rocker switch is not illuminated.	<ul style="list-style-type: none"> ⇒ Red rocker is in OFF (O) position. ⇒ Red rocker switch faulty. 	<ul style="list-style-type: none"> • Switch ON. • Replace switch.
3. Machine does not heat up	<ul style="list-style-type: none"> ⇒ No supply to digital controller ⇒ Digital controller faulty. ⇒ Digital controller indicated control fault. ⇒ Loose/broken wiring or connection heat element faulty. ⇒ Machine has overheated 	<ul style="list-style-type: none"> • See section 1 and 2. • Replace digital controller. • Identify fault and correct. • Find and correct. • Replace element. • Allow to cool down
4. Green rocker switch not illuminated.	<ul style="list-style-type: none"> ⇒ Heating (red rocker) switch not switched on. ⇒ No power to machine. ⇒ Green rocker switch faulty. ⇒ Loose/broken wiring or connection. 	<ul style="list-style-type: none"> • Switch red rocker ON (I) • Connect power supply. • Replace switch. • Find and correct.
5. No illuminated display on counter.	<ul style="list-style-type: none"> ⇒ See section 4. ⇒ Faulty timer 	<ul style="list-style-type: none"> • See section 4. • Replace timer
6. Counter does not count.	<ul style="list-style-type: none"> ⇒ See section 4 and 5. 	<ul style="list-style-type: none"> • See section 4 and 5.

Terms and Conditions

Claims

No claim shall be entertained by the Company unless made in writing. Claims arising from damage or partial loss in transit must reach the Company within 7 days from the date of delivery. Claims for non-delivery must reach the Company within 10 days from the date of dispatch. All other claims must reach the Company within 7 days. Damaged goods must be retained for inspection/collection.

Returns

The Company does not operate a returns policy unless the goods are defective:

In circumstances where the Company agrees to accept return of goods, a charge of 25% of the invoice value will be made.

Damage claim form

Machine: **GASTRO WARMER**

Product code: **EQVIGWCOMP**

Customer name.....

Date of delivery.....

Machine serial number.....

Damage comments.....

.....
.....
.....
.....

Please indicate on the pictures where the unit is damaged

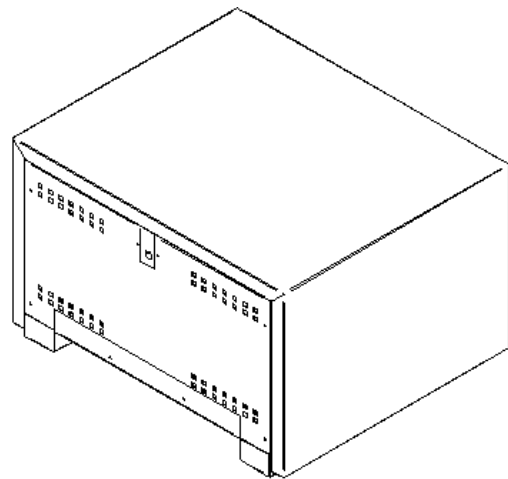
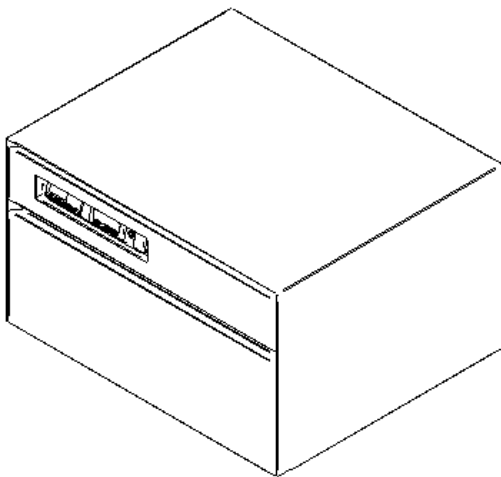

Courier name.....



Please cut this page out and post to **Fast Food Systems**
(The address is on the back of this manual)

Warranty

UNITED KINGDOM AND REPUBLIC OF IRELAND

Excepting where otherwise specified all products are subject to 12 months parts and labour warranty. Goods found defective will be repaired, credited or replaced without charge according to the terms of the Company's standard warranty, provided written notice is given within the guarantee period. In no case will the company be liable for repairs made without it's knowledge or sanction, or for indirect damage, or any consequential loss or expense incurred by purchasers.

Fast Food Systems Ltd, warrants to the original purchaser that the equipment supplied to be free from defective materials or workmanship for a period of 12 (twelve) months.

The following are NOT covered by warranty:

1. Failure or breakdown caused by incorrect installation.
2. Adjustment or calibration of controls - this is a routine maintenance function.
3. Abuse or misuse, including cleaning.
4. Warranty labour is only carried out during normal working hours, calls out of hours may be subject to surcharges.
5. The warranty will commence either on installation or 1 (one) month from date of dispatch - whichever is the sooner.
7. Warranty on spare parts purchased for equipment outside of the warranty period is 3 (three) months from date of sale.
8. Any faulty spare parts replaced under warranty must be returned with 7 days of supply.
9. Warranty is non-transferable.

Fast-Food-Systems Ltd will not be held responsible, financially or otherwise, for any loss of business as a result of equipment breakdown.

NOTES:

Model Number: EQVIGWCOMP

Order ID/Job No.....

Machine serial number.....

Date of Manufacture/...../.....

Date of delivery...../...../.....

Date of commissioning...../...../.....

	<p>ENGLISH</p> <p>Electrical equipment marked with this symbol may not be disposed of in European public disposal systems after 12 August 2005. In conformity with European local and national regulations (EU Directive 2002/96/EC), European electrical equipment users must now return old or end-of-life equipment to the manufacturer for disposal at no charge to the user.</p> <p>Note: For return for recycling, please contact the equipment manufacturer or supplier for instructions on how to return end-of-life equipment for proper disposal.</p>
---	---

Fast Food Systems Limited

Manufacturer & Distributor of Catering Equipment

Unit 1 Headley Park 9 Headley Road East

Woodley Reading Berkshire RG5 4SQ

Tel: 0118 944 1100 Fax: 0118 944 0350

Email: service@fast-food-systems.co.uk

Website: www.fast-food-systems.com

ISSUE: 13 / 01 /2014