

Mega Fries Topper

EQVIMFTOPPER

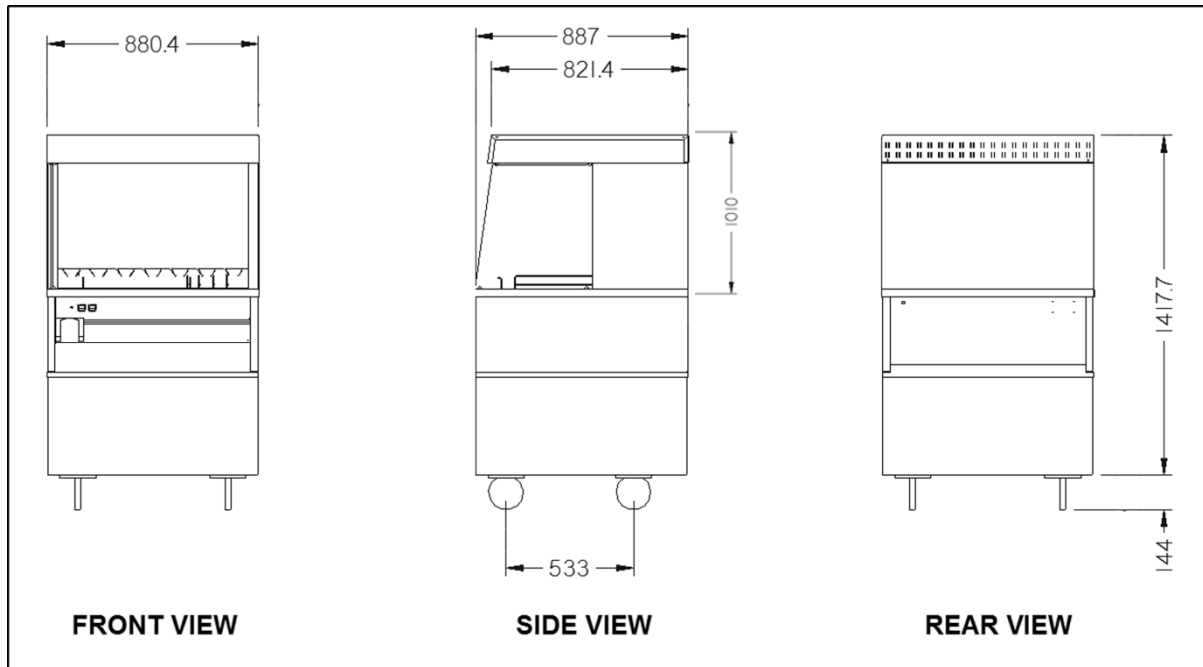

MEGA FRIES TOPPER SPECIFICATION PAGE



MODEL EQVIMFTOPPER

Dimensions	Machine
Height	1020mm
Width	885mm
Depth	890mm
Weight	68kg
Electrical	1 phase, 50Hz AC, 230v, 2.6Kw
Running Amps	13 Amps
Connection Type	BSCHUKO 2/3 PIN PLUG
International Option	N/A

Assembly Instructions

Remove all packing from the unit.

Peel off all protective plastic covering from metal

Wash all removable parts in warm, soapy water and dry them thoroughly.

Installation

Your *Vizu Mega Fries Topper* unit can be set up to work either to the left or right hand side of your fryer(s).

1. Check both heat switch and light switch are in the OFF position.
2. Firstly position the Mega Fries Topper unit in the desired position and lock both front castors in position. Connect this to the power supply.
3. In order to be able to load the Mega Fries Topper unit with fries the side glass needs to be on the opposite side of the machine to the fryer(s). If the glass needs to be moved this is possible by unscrewing the grub screws and sliding the glass out, to re-fit simply slide back in and tighten screws.

Operating Instructions

1. Use the switch with the red LED to start heating of the under pan element and rear pair of heat lamps.
2. Use the switch with the green LED to light front row heat lamps.
3. Allow 20 minutes to reach operating temperature.
4. When fries are cooked lift out of oil and allow to drain.
5. When draining is complete move basket across to Mega Fries Topper serving area and tip contents carefully into tray.
6. Take the salt shaker from its holder and add salt as desired.
7. Now using the fry scoop slide a bag/box over the bottom and scoop chips.
8. The bags full of fries can now be placed in the bagging rack prior to sale.

Note: It is important that fries are held for no longer than **10 minutes**. After this time the quality of the fries will deteriorate.

Additional equipment, to suit Mega Fries Topper

As well as the equipment supplied the Mega Fries Topper is fitted with two handles inside the chip draining plate that can double up as a chip scoop holder.

1. Chip Bagging Scoop holder & handle



Cleaning: Every Day

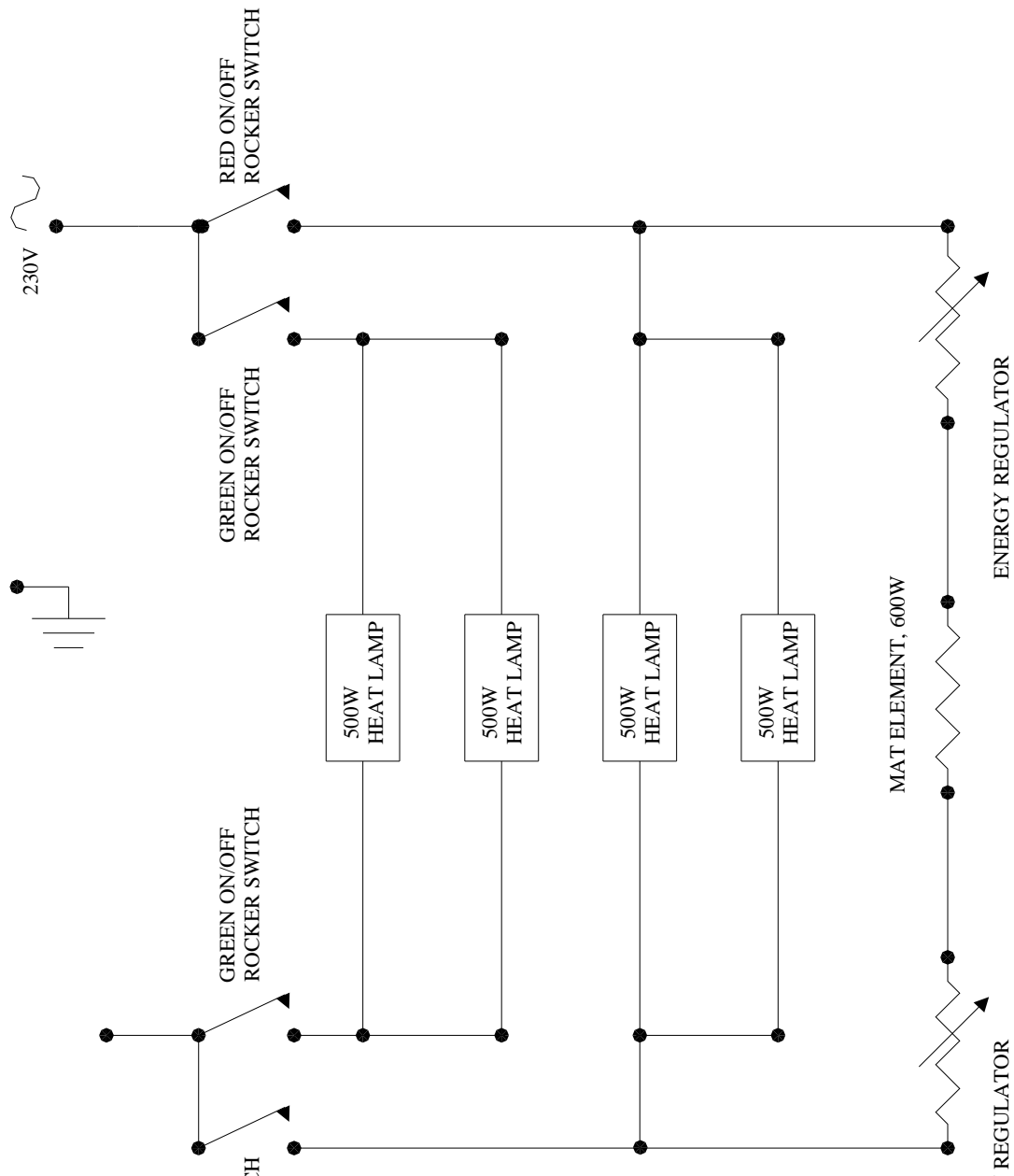

1. 'Switch OFF' and remove electrical cord from power supply. Allow unit to cool
2. First of all remove the bagging rack and wash in warm soapy water
3. Next remove the chip chute and again wash in warm soapy water
4. Finally remove the perforated serving tray, wash in warm soapy water
5. Wipe the inner tray and all exterior surfaces of machines with a soft damp cloth
6. Remove side glass by unscrewing the grub screws and sliding the glass out, to re-fit simply slide back in and tighten screws. Should be cleaned with warm soapy water
7. Dry all parts thoroughly and refit in order they were removed



WIRING DIAGRAM	PROTOTYPE NAME 48 MEGA FRIES			
	DRAWN RT	DESIGNED	DATE 11/10/2004	PROTOTYPE CODE EQVIMF
WIRING DIAGRAM	 Property of Fast Food Systems Ltd. May not be reproduced or used for purposes other than those for which it is supplied, without written permission.			
	Unit 1, Headley Park 9, Headley Road East, Woodley, Reading, Berkshire. RG5 4SQ.			

Spare Parts List

PART NO.	PART NAME	NO. REQUIRED	
MF5057071010	ENERGY STAT	1	
VISW15	GREEN ROCKER SWITCH	1	
VILE14	ROCKER SWITCH COVER	2	
VISW17	RED ROCKER SWITCH	1	
MF374-1029	RED NEON	1	
MF500HOLDER	LIGHT GANTRY	4	
MFELBCE600W	MAT ELEMENT	1	
MFCOB-CR	GLASS CLAMP	8	
MF500PLUGIN	PLUG IN LAMP	4	

MFEUROCONVERT	EURO TO UK CONVERTER	1	
MFMEGAGLASS2	SIDE GLASS	1	

Fault Finding

Any servicing must only be carried out by qualified personnel. Machine must be removed from electrical supply before any servicing.

Problem	Probable Cause	Solution
1. Indicated ON/OFF switch does not light up	⇒ No power to machine. ⇒ ON/OFF switch off ⇒ ON/OFF switch faulty	<ul style="list-style-type: none"> • Check machine is plugged in and switched on. • Check fuse in 13a plug. • Check circuit breaker at main supply board is in (ON). • Check Switch • Replace switch.
2. Unit will not heat up.	⇒ No power to machine. ⇒ Red indicator switch OFF ⇒ Red indicator switch faulty ⇒ Thermostat faulty. ⇒ Heat element faulty	<ul style="list-style-type: none"> • See section 1 • See section 1 • See section 1 • Check and replace if necessary • Check and replace if necessary
3. Lights do not illuminate	⇒ No power to machine ⇒ Green indicator switch off ⇒ Green indicator switch faulty ⇒ Heat lamp broken	<ul style="list-style-type: none"> • Check machine is plugged in and switched on. • Check fuse in 13amp plug. • Check circuit breaker at main supply board is in (ON) • Check switch • Replace switch • Replace heat lamps

Terms and Conditions

Claims

No claim shall be entertained by the Company unless made in writing. Claims arising from damage or partial loss in transit must reach the Company within 7 days from the date of delivery. Claims for non-delivery must reach the Company within 10 days from the date of dispatch. All other claims must reach the Company within 7 days. Damaged goods must be retained for inspection/collection.

Returns

The Company does not operate a returns policy unless the goods are defective:

In circumstances where the Company agrees to accept return of goods, a charge of 25% of the invoice value will be made.

Damage claim form

Machine: **MEGA FRIES TOPPER**
Product code: **EQVIMFTOPPER**

Customer name.....

Date of delivery.....

Machine serial number.....

Damage comments.....

.....

.....

.....

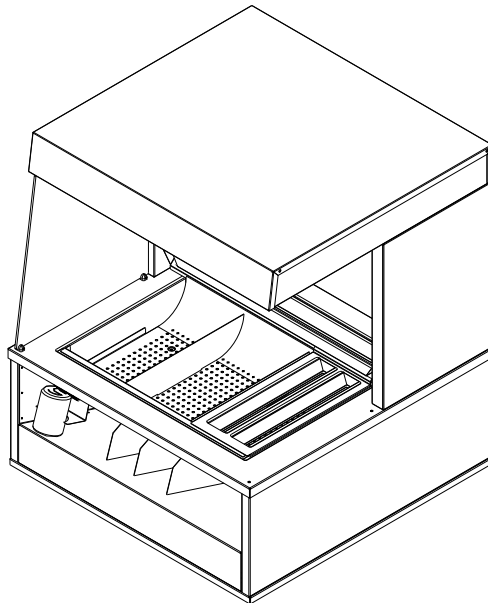

Please indicate on the picture where the unit is damaged.



Courier name.....

Please cut this page out and post to **Fast Food Systems**
(The address is on the back of this manual)

Warranty

UNITED KINGDOM AND REPUBLIC OF IRELAND

Excepting where otherwise specified all products are subject to 12 months parts and labour warranty. Goods found defective will be repaired, credited or replaced without charge according to the terms of the Company's standard warranty, provided written notice is given within the guarantee period. In no case will the company be liable for repairs made without it's knowledge or sanction, or for indirect damage, or any consequential loss or expense incurred by purchasers.

Fast Food Systems Ltd, warrants to the original purchaser that the equipment supplied to be free from defective materials or workmanship for a period of 12 (twelve) months.

The following are NOT covered by warranty:

1. Failure or breakdown caused by incorrect installation.
2. Adjustment or calibration of controls - this is a routine maintenance function.
3. Abuse or misuse, including cleaning.
4. Warranty labour is only carried out during normal working hours, calls out of hours may be subject to surcharges.
5. The warranty will commence either on installation or 1 (one) month from date of dispatch - whichever is the sooner.
7. Warranty on spare parts purchased for equipment outside of the warranty period is 3 (three) months from date of sale.
8. Any faulty spare parts replaced under warranty must be returned with 7 days of supply.
9. Warranty is non-transferable.

Fast-Food-Systems Ltd will not be held responsible, financially or otherwise, for any loss of business as a result of equipment breakdown.

MODEL NUMBER.....

ORDER ID/JOB NO.....

MACHINE SERIAL NUMBER.....

DATE OF MANUFACTURE/...../.....

DATE OF DELIVERY...../...../.....

DATE OF COMMISSIONING...../...../.....

ENGLISH



Electrical equipment marked with this symbol may not be disposed of in European public disposal systems after 12 August 2005. In conformity with European local and national regulations (EU Directive 2002/96/EC), European electrical equipment users must now return old or end-of-life equipment to the manufacturer for disposal at no charge to the user.

Note: For return for recycling, please contact the equipment manufacturer or supplier for instructions on how to return end-of-life equipment for proper disposal.

Fast Food Systems Limited

Manufacturer & Distributor of Catering Equipment

Unit 1 Headley Park 9 Headley Road East

Woodley Reading Berkshire RG5 4SQ

Tel: 0118 944 1100 Fax: 0118 944 0350

Email: service@fast-food-systems.co.uk

Website: www.fast-food-systems.com

ISSUE: 02/MAY/2012