

Server

EQVI003S

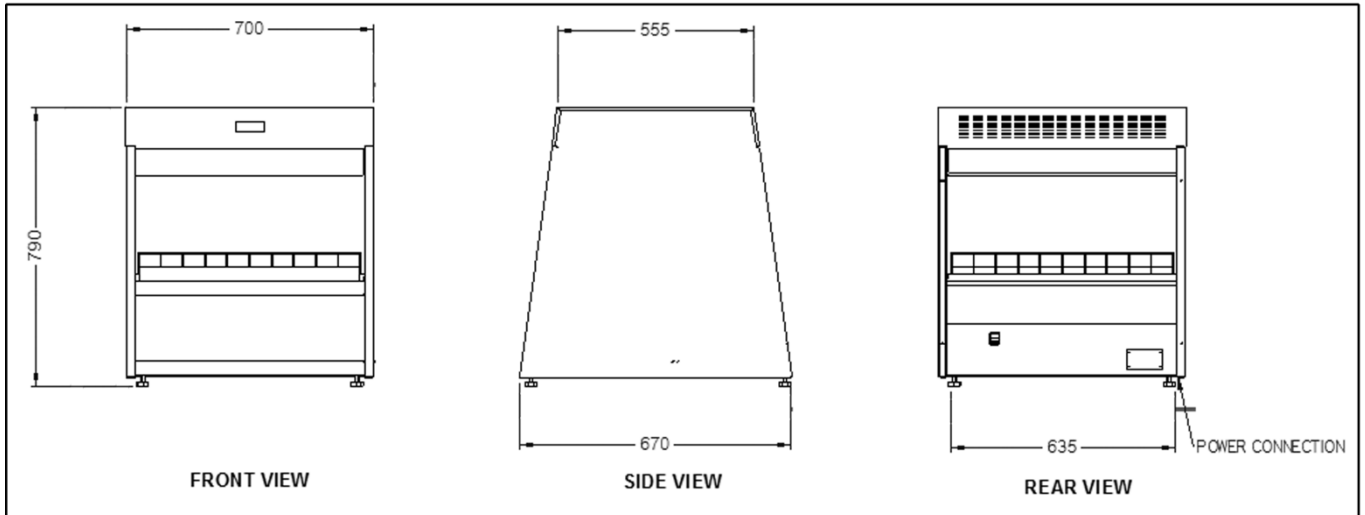

SERVER SPECIFICATION PAGE



Model EQVI003S

Dimensions	Machine
Height	790mm
Width	700mm
Depth	670mm
Weight	48kg
Electrical	1 phase, 50HZ AC, 230v, 1.6Kw
Running Amps	7 Amps
Connection Type	BSCHUKO 2/3 PIN PLUG
International Option	N/A

All **Vizu Server** have been tested and checked for proper operation before leaving the factory.

Upon delivery please check the unit for damage. If the unit is damaged, contact the carrier, or fast food systems, immediately and file a damage claim (found in the back of the manual) Please retain all packing materials.

Damage must be reported within 7 days of delivery

General Description

The unit has been designed to hold fries once cooked, bagged or boxed foods ready for serving.

Assembly Instructions

Remove all packing from the unit.

Peel off all protective plastic covering from metal.

Remove drain plate.

Wash all removable parts in warm, soapy water and dry them thoroughly

Installation

Position the Server in desired position, close to a suitable electrical supply and connect.

The unit is supplied with a 13amp, 3 pin UK plug, fitted with a 10amp fuse.

Operating Instructions

1. With pan and bagging rack empty. Switch the heat lamps "ON"
2. Allow unit to heat up for 20 minutes.
3. Dump fries into pan, salt fries as required.
4. Do not overfill dump pan, as fries at the bottom will go soft.
5. Bag and serve as quickly as possible.

Cleaning Instructions

1. Disconnect the unit from its power supply.
2. Remove bagging rack, pan and dump tray; wash and dry thoroughly.
3. Clean all stainless steel surfaces with proprietary stainless steel cleaner, such as Sheila Shine and a soft lint free cloth.

NOTE: DO NOT USE ABRASIVE CLEANERS OR PADS AND DO NOT BLEACH.

4. Dry all surfaces thoroughly removing all moisture.
5. Re-connect to power supply.









Faultfinder

Any servicing must be carried out by qualified personnel.

Disconnect from power before servicing.

Problem	Possible Cause	Solution
LED power indicator not illuminated	<ul style="list-style-type: none"> - No power to machine - LED is faulty 	<ul style="list-style-type: none"> - Check machine is plugged into electrical supply and switched on. - Check circuit breaker for electrical supply. - Check fuse - Replace LED
ON / OFF switch not illuminated	<ul style="list-style-type: none"> - No power to machine - ON / OFF switch in OFF position - ON / OFF switch damaged or faulty 	<ul style="list-style-type: none"> - See 1 - Switch ON - Replace or refit
Heat lamps are not illuminated	<ul style="list-style-type: none"> - No power to machine. - ON / OFF switch in OFF position - One or both lamps faulty or incorrectly fitted. - Electrical components and / or wiring, damaged or faulty 	<ul style="list-style-type: none"> - See 1 - Switch ON - Replace or refit - Service maintenance to find and correct
Base heat not working	<ul style="list-style-type: none"> - No power to machine - ON / OFF switch on OFF position - Heat element faulty or not working - Energy regulator not working 	<ul style="list-style-type: none"> - See 1 - Switch ON - Check / replace element - Replace energy regulator

Spare Parts Listing

PART NO.	PART NAME	No. Req.	
MFELBCE600W	Element Mat	1	
VISW17	Red Rocker Switch	1	
VILE14	Switch Cover	1	
MF374-1029	10mm LED Power Indicator	1	
MF500PLUGIN	500W Lamp	2	
MF500HOLDER	Lamp Holder	2	
MFE5057071010	Regulator	1	
MFRTH34AFM	Adjustable Foot	4	

Warning, when replacing bulbs

The lamps whilst being a high output unit are fragile. They must be handled with care and they must be kept clean. Guards are fitted to prevent dirt and grease contacting the bulbs. Grease from fingers will weaken the surface of the bulb this will lead to fracture and failure; bulbs should always be held using clean gloves or a wad of tissue to grip the bulb in.

Warning, when replacing energy regulator

The energy regulator is mounted internally and factory present. Before having energy regulator replaced check if the unit has just been serviced, if it has then have the control setting checked before replacing it.

Wiring Diagram

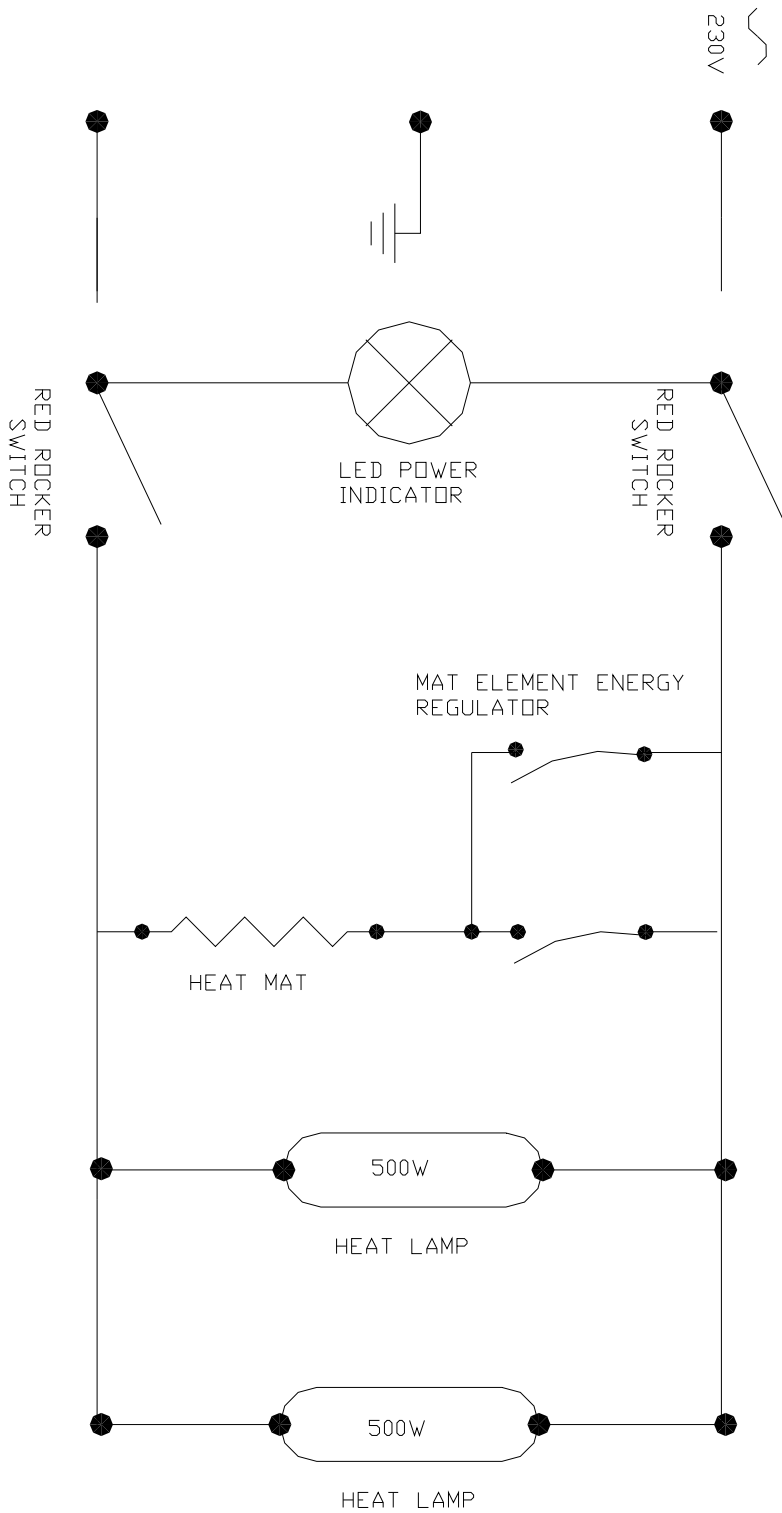

WIRING DIAGRAM		Prototype Name	
Drawn	Designed	21 SERVER	
RG	31/05/2012	Date	31/05/2012
 Property of Fast Food Systems Ltd. May not be reproduced or used for purposes other than those for which it is supplied without written permission.		Prototype No.	EQV1003S
		Build No.	06
Unit 1, Headley Park 9, Headley Road East Woodley, Reading RG5 4SQ			

Damage claim form

Machine: **Server**

Product code: **EQVI003S**

Customer name.....

Date of delivery.....

Machine serial number.....

Damage comments.....

.....
.....
.....

Please indicate on the picture where the unit is damaged

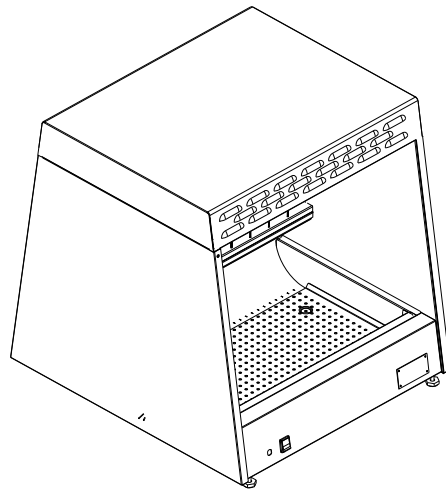

Courier name.....

Please cut this page out and post to **Fast Food Systems**
(The address is on the back of this manual)

Terms and Conditions

Claims

No claim shall be entertained by the Company unless made in writing. Claims arising from damage or partial loss in transit must reach the Company within 7 days from the date of delivery. Claims for non-delivery must reach the Company within 10 days from the date of dispatch. All other claims must reach the Company within 7 days. Damaged goods must be retained for inspection/collection.

Returns

The Company does not operate a returns policy unless the goods are defective:

In circumstances where the Company agrees to accept return of goods, a charge of 25% of the invoice value will be made.

Warranty

UNITED KINGDOM AND REPUBLIC OF IRELAND

Excepting where otherwise specified all products are subject to 12 months parts and labour warranty. Goods found defective will be repaired, credited or replaced without charge according to the terms of the Company's standard warranty, provided written notice is given within the guarantee period. In no case will the company be liable for repairs made without its knowledge or sanction, or for indirect damage, or any consequential loss or expense incurred by purchasers.

Fast Food Systems Ltd, warrants to the original purchaser that the equipment supplied to be free from defective materials or workmanship for a period of 12 (twelve) months.

The following are NOT covered by warranty:

1. Failure or breakdown caused by incorrect installation.
2. Glass parts, electric lamps or door seals.
3. Adjustment or calibration of controls - this is a routine maintenance function.
4. Abuse or misuse, including cleaning.
5. Warranty labour is only carried out during normal working hours, calls attended to out of hours may be subject to surcharges.
6. The warranty will commence either on installation or 1 (one) month from date of dispatch - whichever is the sooner.
7. Warranty on spare parts purchased for equipment outside of the warranty period is 3 (three) months from date of sale.
8. Any faulty spare parts replaced under warranty must be returned with 7 days of supply.
9. Warranty is non-transferable.

Fast-Food-Systems Ltd will not be held responsible, financially or otherwise, for any loss of business as a result of equipment breakdown.

Model Number.....

Order ID/Job No.....

Machine serial number.....

Date of Manufacture/...../.....

Date of delivery...../...../.....

Date of commissioning...../...../.....



ENGLISH

Electrical equipment marked with this symbol may not be disposed of in European public disposal systems after 12 August 2005. In conformity with European local and national regulations (EU Directive 2002/96/EC), European electrical equipment users must now return old or end-of-life equipment to the manufacturer for disposal at no charge to the user.

Note: For return for recycling, please contact the equipment manufacturer or supplier for instructions on how to return end-of-life equipment for proper disposal.

Fast Food Systems Limited

Manufacturer & Distributor of Catering Equipment

Unit 1 Headley Park 9 Headley Road East

Woodley Reading Berkshire RG5 4SQ

Tel: 0118 944 1100 Fax: 0118 944 0350

Email: service@fast-food-systems.co.uk

Website: www.fast-food-systems.com

ISSUE: 15 August 2013