

DOUBLE DECKER 8 LANE FOOD CHUTE

EQVI017



- All stainless steel construction
- Adjustable lane guides
- Independently heated tiers
- Complete with lane listing strips and holders

2 TIER FOOD CHUTE SPECIFICATION PAGE

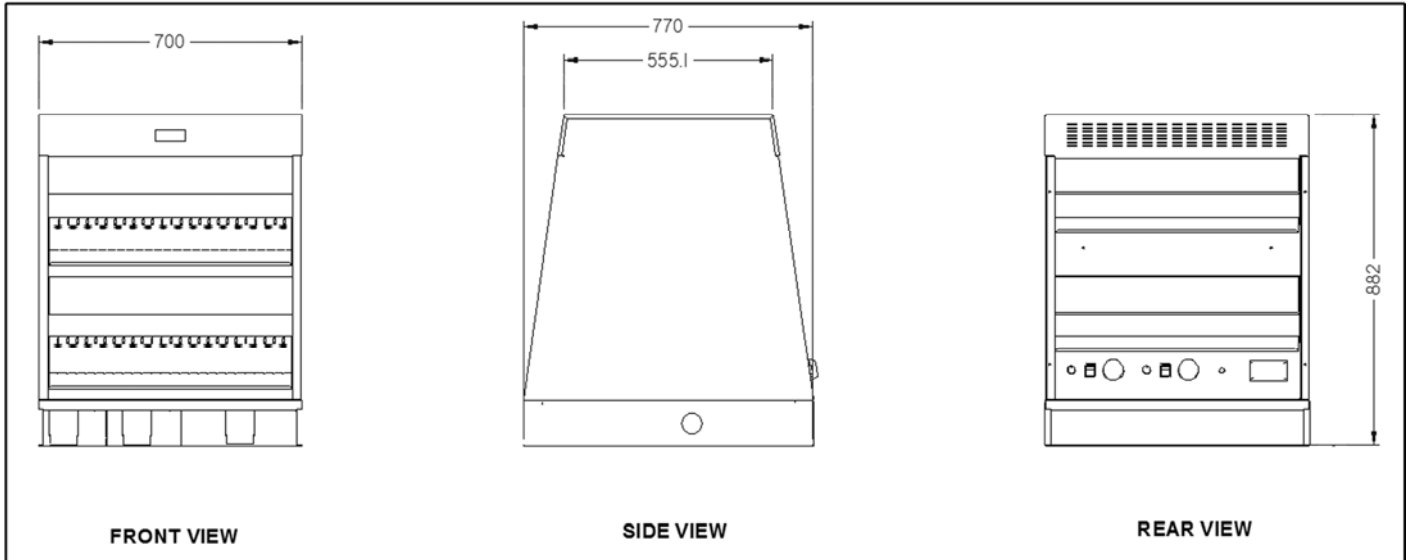

Model EQVI017

Dimensions	Machine
Height	785mm
Width	700mm
Depth	775mm
Weight	60kg
Electrical	1 phase, 50Hz AC, 230v, 2.2Kw
Running Amps	10 Amps
Connection Type	BSCHUKO 2/3 PIN PLUG
International	N/A

All **Vizu 2 Tier Food Chutes** have been tested and checked for proper operation before leaving the factory.

Upon delivery please check the unit for damage. If the unit is damaged, contact the carrier, or Fast Food Systems, immediately and file a damage claim (found in the back of the manual) Please retain all packing materials.

Damage must be reported within 7 days of delivery.

Assembly Instructions

1. Remove all packing from the unit.
2. Peel off all protective plastic covering from metal
3. Wash all removable parts in warm, soapy water and dry them thoroughly.
4. Place chutes and guide bars in position.

Installation

Position the Vizu Double Decker Food Chute in desired position, close to a suitable electrical supply and connect.

Operating instructions

1. Switch the two red rocker switches 'ON' to operate the top and bottom lights and ceramic elements
2. Twist the two big dials into desired position to activate the top elements and bottom mat and elements. Note: start with '0' and adjust upwards slowly until the optimum ambient temperature is reached, this depends on the food product and it's packaging to what the final setting will be. In certain cases this additional heat source will not be required.
3. Set the lighting to the required level with the smaller round dials (The dimmer switches).
4. Allow unit to heat up for 15 minutes.

Cleaning instructions

1. Disconnect the unit from its power supply.
2. Remove chutes and clean.
3. Clean all stainless steel surfaces with proprietary stainless steel cleaner, such as Sheila Shine and a soft lint free cloth. **Note: Do NOT use abrasive cleaners or pads and do NOT bleach.**
4. Wipe ceramic elements only when they are cold with a damp clean cloth.
5. Do NOT touch or clean (quartz) heat lamps with fingers, as this will reduce the life of the tubes.
6. Dry all surfaces thoroughly removing all moisture.

Spare Parts List

PART NO.	DESCRIPTION	QTY	PICTURE
MF100WRJ	Lamps	1	
BETH4300	Lower bulb	1	
EQVIZULABELS	White menu labels	4	
MF354Z	Ceramic block	10	
MF374-1029	10mm Low profile lens LED indicator, 230V AC	1	
MF939/27208	Ceramic lamp holder	4	
MFE5057071010	Energy regulator & control dial	2	
MFELBCE600W	Mat element	1	
MFFSC300W	Ceramic infrared	4	
MFRT34AFM	Adjustable feet	4	

PART NO.	DESCRIPTION	QTY	PICTURE
RS655-638	Dimmer control	2	
MFMOQB6	Knob for dimmer	2	
VILE14	Switch cover	2	
VISW17	Red rocker switch	2	

Fault finder

Qualified personnel must carry out any servicing.
 Disconnect from power before servicing.

Problem	Possible cause	Solution
1. LED Indicator not illuminated	No power to machine.	Check machine is plugged in. Check for correct rated fuse in plug. Check circuit breaker at mains supply board is on.
2. ON/OFF switches not illuminated 2a. LED indicator not illuminated	No power to machine. Wiring / component faulty	Check machine is plugged in and switched on. Check for right rated fuse in plug. Check circuit breaker at mains supply board is in i.e. ON. Find & correct
3. ON/OFF switches are illuminated but there is no heat or light	ON/OFF switches are in OFF position. Dimmer switches and energy regulators in OFF position. ON/OFF switch faulty.	Switch ON. Switch ON. Replace switch.
4. Upper lights not illuminated.	Dimmer switch in OFF position. Halogen lamp faulty. Dimmer switch faulty. Wiring/component fault.	Switch ON. Replace. Replace. Find & correct.
5. Lower lights not illuminated	As section 3.	As section 3
6. Upper section does not heat up.	Energy regulator in OFF position. Energy regulator faulty. One or both ceramic heaters faulty.	Switch ON. Replace. Replace ceramic heater
7. Lower section does not heat up.	As section 5. Base heat mat faulty.	As section 5. Replace mat element.

WIRING DIAGRAM

**EQV1017 8 LANE FOOD CHUTE (BC8)
 EXPLODED VIEW**

- 15-01 INNER SIDES
- 15-02 LOWER SHELF
- 15-04 HOOD
- 15-03 LIGHT REFLECTOR
- 15-07 BASE
- 15-10 UPPER SHELF
- 15-11 LOWER REFLECTIVE SKIRT
- 15-12 UPPER REFLECTIVE SKIRT
- 15-13 TOP CHUTE
- 15-14 LOWER INNER HOOD
- 15-15 BOTTOM CHUTE
- 15-16 UPPER INNER HOOD
- 15-17 LABEL HOLDER
- 15-22 OUTER SIDES
- 15-24 ELEMENT HOLDER
- 15-35 HOOD LIGHT HOLDER
- BETH4300 LAMP
- HAS31ERMHT REGULATOR
- LNKNG2 ENERGY REGULATOR KNOBS
- MFELBC E MAT ELEMENT (800W)
- MFMC5-FOLE MAT ELEMENT
- MSW17 V1LE14 ROCKER SWITCH AND COVER
- MF5C300W CERAMIC ELEMENTS
- MF939/230 LAMP HOLDERS
- MFRTH34AFM ADJUSTABLE FEET
- MFPLATE SERIAL PLATE
- RS655-638 DIMMER CONTROLS
- RS498-839 DIMMER KNOB

DRAWN BY: JEZ
 DATE: 25/10/2005
 ISSUE: 06

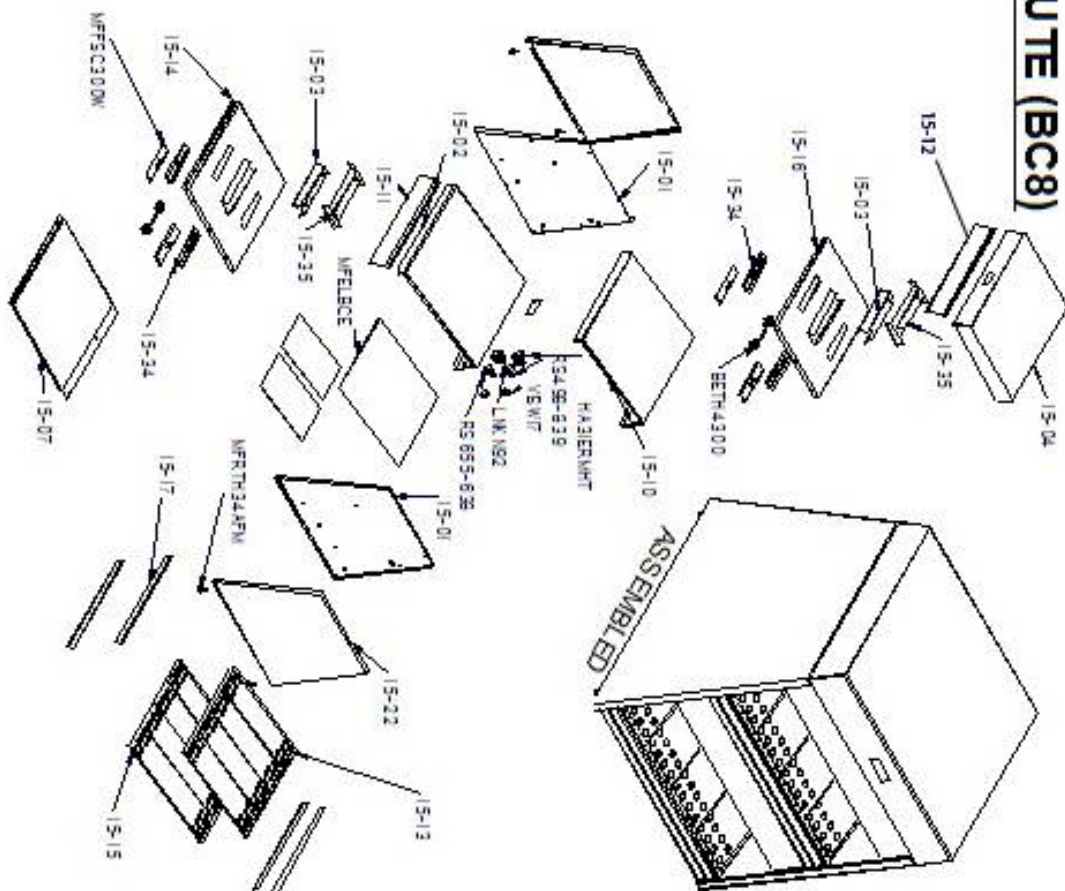

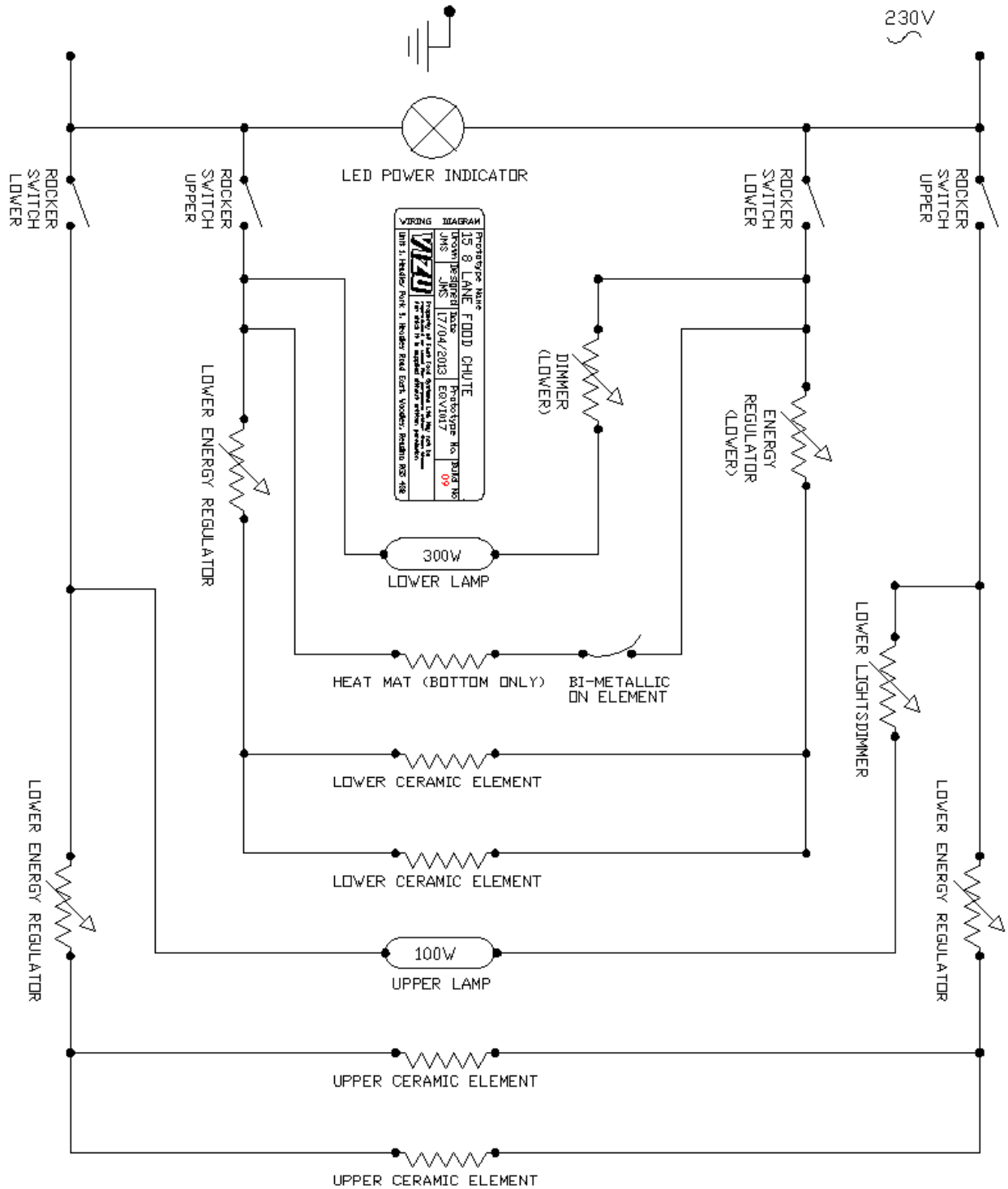

Terms and Conditions

Claims

No claim shall be entertained by the Company unless made in writing. Claims arising from damage or partial loss in transit must reach the Company within 7 days from the date of delivery. Claims for non-delivery must reach the Company within 10 days from the date of dispatch. All other claims must reach the Company within 7 days. Damaged goods must be retained for inspection/collection.

Returns

The Company does not operate a returns policy unless the goods are defective:

In circumstances where the Company agrees to accept return of goods, a charge of 25% of the invoice value will be made.

Damage claim form

Machine: **DOUBLE DECKER 8 LANE FOOD CHUTE**

Product code: **EQVI017**

Customer name.....

Date of delivery.....

Machine serial number.....

Damage comments.....

.....

.....

.....

.....

Please indicate on the picture where the unit is damaged

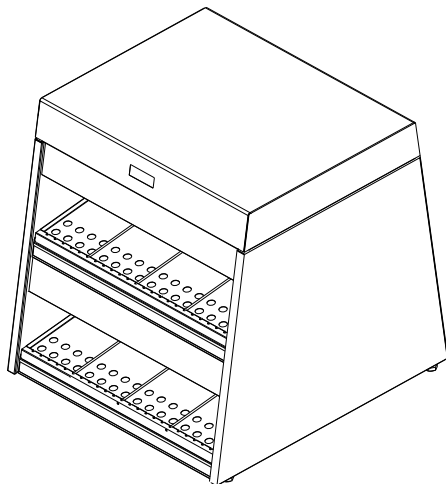

Courier name.....



Please cut this page out and post to **Fast Food Systems**
(The address is on the back of this manual)

Warranty

UNITED KINGDOM AND REPUBLIC OF IRELAND

Excepting where otherwise specified all products are subject to 12 months parts and labour warranty. Goods found defective will be repaired, credited or replaced without charge according to the terms of the Company's standard warranty, provided written notice is given within the guarantee period. In no case will the company be liable for repairs made without it's knowledge or sanction, or for indirect damage, or any consequential loss or expense incurred by purchasers.

Fast Food Systems Ltd, warrants to the original purchaser that the equipment supplied to be free from defective materials or workmanship for a period of 12 (twelve) months.

The following are NOT covered by warranty:

1. Failure or breakdown caused by incorrect installation.
2. Adjustment or calibration of controls - this is a routine maintenance function.
3. Abuse or misuse, including cleaning.
4. Warranty labour is only carried out during normal working hours, calls out of hours may be subject to surcharges.
5. The warranty will commence either on installation or 1 (one) month from date of dispatch - whichever is the sooner.
7. Warranty on spare parts purchased for equipment outside of the warranty period is 3 (three) months from date of sale.
8. Any faulty spare parts replaced under warranty must be returned with 7 days of supply.
9. Warranty is non-transferable.

Fast-Food-Systems Ltd will not be held responsible, financially or otherwise, for any loss of business as a result of equipment breakdown.

MODEL NUMBER.....**EQVI017**.....

ORDER ID/JOB NO.....

MACHINE SERIAL NUMBER.....

DATE OF MANUFACTURE/...../.....

DATE OF DELIVERY...../...../.....

DATE OF COMMISSIONING...../...../.....



ENGLISH

Electrical equipment marked with this symbol may not be disposed of in European public disposal systems after 12 August 2005. In conformity with European local and national regulations (EU Directive 2002/96/EC), European electrical equipment users must now return old or end-of-life equipment to the manufacturer for disposal at no charge to the user.

Note: For return for recycling, please contact the equipment manufacturer or supplier for instructions on how to return end-of-life equipment for proper disposal.

Fast Food Systems Limited

Manufacturer & Distributor of Catering Equipment

Unit 1 Headley Park 9 Headley Road East

Woodley Reading Berkshire RG5 4SQ

Tel: 0118 944 1100 Fax: 0118 944 0350

Email: service@fast-food-systems.co.uk

Website: www.fast-food-systems.com

ISSUE: 08 APRIL 2013