

# ORWAK®

## Environmental Services

# Model 3610

### Benefits

- Savings on your waste collection
- Tidy premises
- Compliance to meet your legal obligations
- Space and time saving



# BALERS

# Model 3610

- Front loading
- Large loading aperture
- Sliding door
- Equipped with autostart
- High performance
- 50-ton big baler
- Generates 550 kg bales
- Quiet operation
- Fast cycle time



A= 3566 mm  
 B= 1770 mm  
 C= 1321 mm  
 D= 2680 mm  
 E= 1262 mm  
 F= 2390 mm

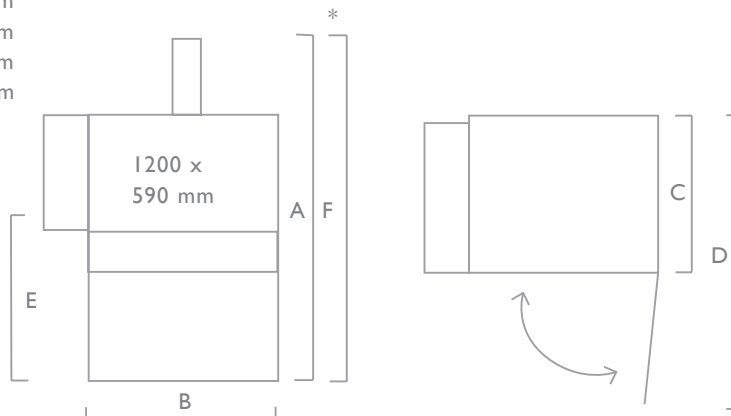

\* Transport Height

## SPECIFICATIONS

### CYCLE TIME

33 secs

### WEIGHT

Total: 2300 kg

### MACHINE DIMENSIONS

Height: 3566 mm  
 Width: 1770 mm  
 Depth: 1321 mm

### CHAMBER DIMENSIONS (INTERNAL)

Width: 1200 mm  
 Depth: 900 mm  
 Height: 1140 mm

### BALE SIZE

Width: 1200 mm  
 Depth: 900 mm  
 Height: 1735 mm  
 Weight (cardboard): up to 550kg

### TOPCOAT

Two part paint and powder coat with phosphatising as base

### HYDRAULIC DATA

Working pressure (HP): 200 bar  
 Relief pressure (HP): 220 bar  
 Press force (HP): 50 ton (500 kN)  
 Press force/cm<sup>2</sup> (HP): 4,86 kg  
 Piston stroke: 1200 mm

### RECOMMENDED OIL: TEMP > 5°C

64l ISO VG 32-68 SAE 10

### ELECTRICAL DATA

Operating power: 3-phase 3x400, 50Hz  
 Electrical connection: 5 pin CEE-plug, 16 A  
 Operating voltage: 24V AC/DC  
 via transformer

### NOISE LEVEL

< 63.9 dB (A)

VOLTAGE	FUSE	IP
3 PHASE, 3X400 V, 50 HZ	16A	55

a **phs** Group company

Tel: 0121 565 7426 Fax: 0121 565 7427  
 Email: orwaksales@phs.co.uk Website: www.orwak.co.uk  
 Orwak Environmental Services Ltd, Unit 6,  
 Alpha Industrial Park, Bevan Way, Smethwick B66 1BZ

Printed on recycled paper