



HI-DUTY

resilient mounting material



• **TICO** •
RF/PA

• **TICO** •
PF/PA

• **TICO** •
FF/PA



Tiflex

TICOBRHD0001

HI-DUTY

resilient mounting material

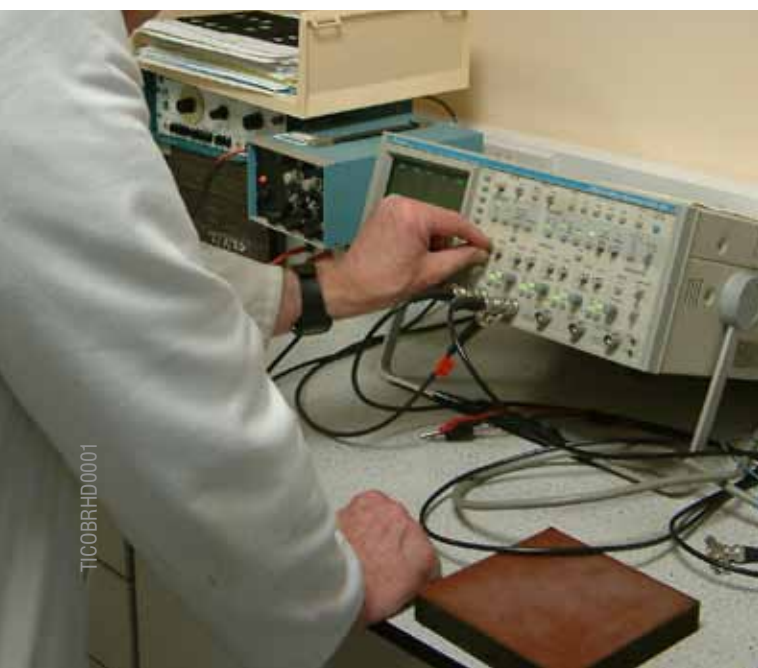

The TICO brand is synonymous with high performance and value in the field of vibration attenuating machinery mounting. Tiflex is proud to have been involved in a wide variety of projects throughout the world where TICO products have been employed to provide effective solutions to the problems of noise and vibration.

We are committed to the research and development of the TICO anti-vibration product ranges and have both the experience and resources necessary to respond to the exacting technology requirements of today's market. We are committed to providing the very best in product quality and customer service.

Working closely with our customers, our polymer technologists work to develop solutions to a variety of engineering problems particularly those requiring high performance and product durability. We use the highest grade of raw materials, advanced production techniques and strict quality control to maintain consistent product standards.

Our TICO Hi-Duty range, available in three grades, covers applications from light weight instrumentation mounting through to anvil pads and spigot packing for the largest of mechanical hammers.



TICO Hi-Duty materials are designed to reduce shock, impact loads and vibration in a wide range of applications in heavy industries where arduous conditions prevail. They have the strength and resilience to cushion massive impacts, absorb fierce shock loads, and attenuate severe vibration from heavy plant.

This sophisticated range is made up of three products, each with its own individual features that can be tailored to meet the needs of the customer.

- TICO RF/PA
- TICO PF/PA
- TICO FF/PA

Benefits

- Very tough and resilient
- Absorbs highly destructive shock loads without reducing efficiency
- Prolongs the life of machinery
- Retains its properties under extreme conditions
- Can be custom moulded (PF/PA)
- Unaffected by dampness or environmental changes
- Composition can be varied to suit specific duties

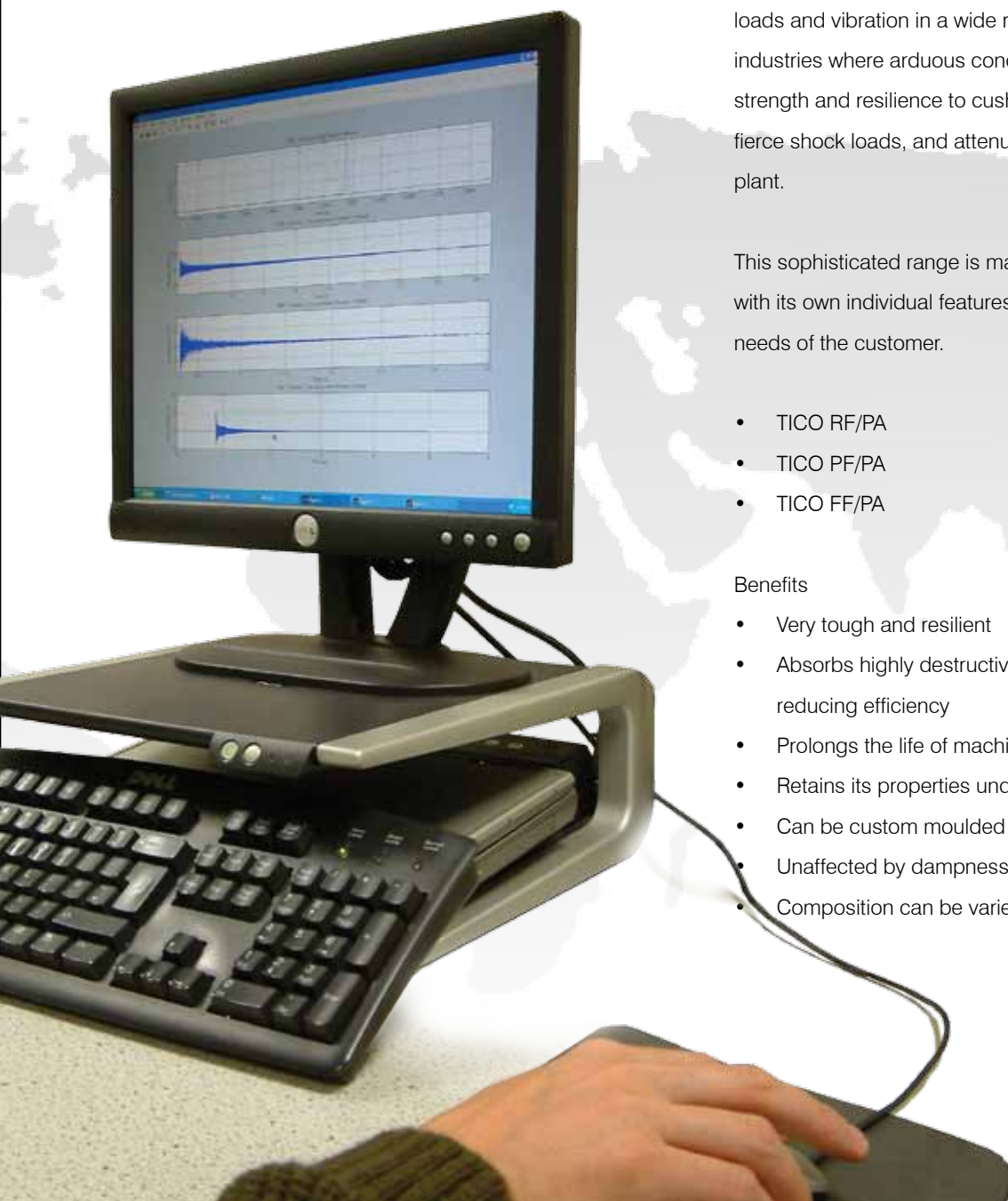

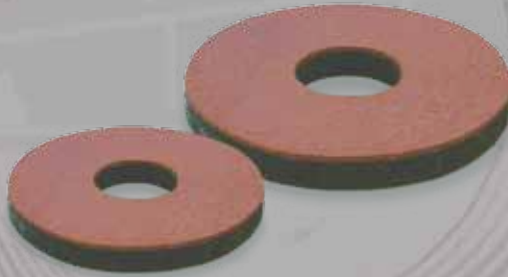
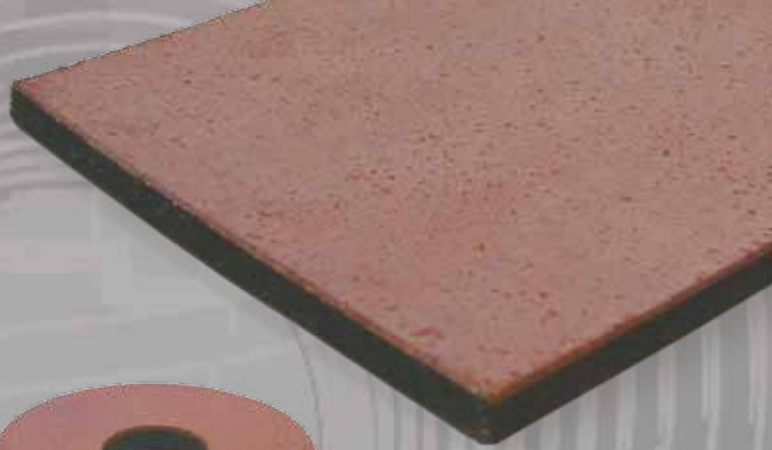

RF/PA

Although particularly designed for use under power and drop hammer anvils, this grade is eminently suitable for noise and vibration reduction in most heavy duty applications and has many uses in general industry where heavy duty pads are required.

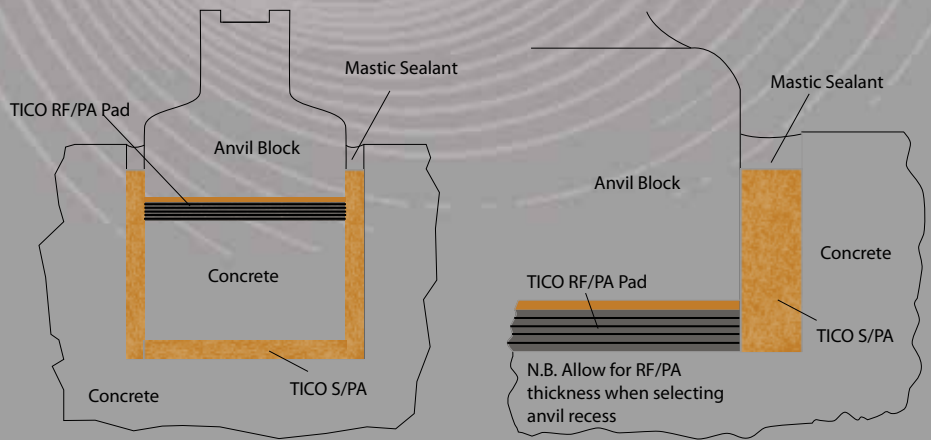

Typical Anvil Applications

TICO RF/PA is a high load-bearing pad material, comprising plies of synthetic rubber proofed cotton with interplies of neoprene rubber, modified with cellular particles. One side is faced with a thin layer of rubber bonded cork to absorb irregularities in the seating surface. It is resistant to water, oil, cooling fluids and other media generally encountered in heavy industry.

The tough yet resilient nature of TICO RF/PA ensures continuous heavy impact absorption whilst the interply construction provides extended life under high stress conditions in both exterior and protected applications.

Typical Applications

- Anvil pads on new and existing forging hammer installations
- Anti-vibration mounts on large plant
- Heavy duty buffers
- Pipe support and isolation (oil and gas industry)
- Support of TICO Sliding Bearings



PF/PA

For this material, plies of synthetic rubber proofed cotton fabrics are vulcanised together to form a smooth finish pad of great durability.

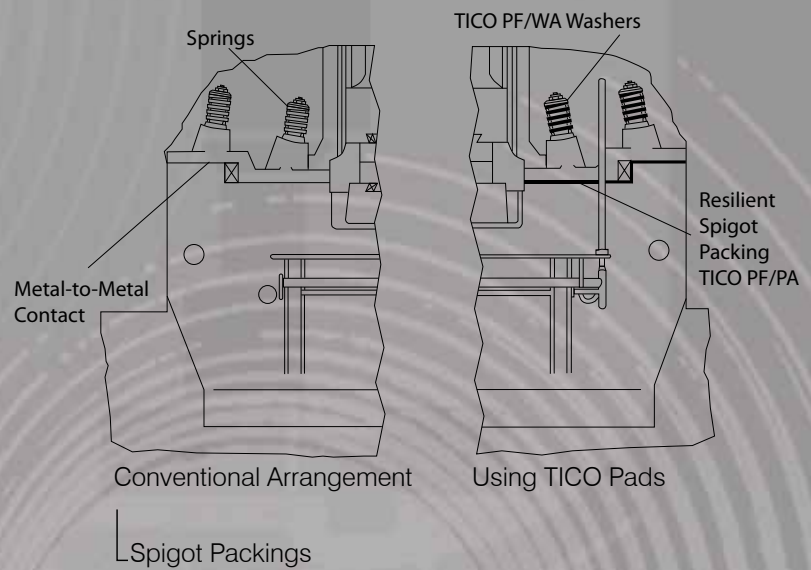

TICO PF/PA should be used where the material's high stiffness is more important than a predictable response to impact. Typical applications are for impact absorption on piling hammers, sheet piling buffers and as resilient spigot packings - the absorbing layer between sections of hammer frames - which are frequently used in conjunction with TICO PF/PA washers which replace the strings or Belleville washers on the tie bolts. It is also ideal for preventing fretting corrosion and spalling of concrete seatings. A further application is its use on heavy industrial machinery, for mounting equipment on the main frame to reduce noise and vibration and increase operator comfort.

Typical Applications

- Impact absorption on piling hammers
- Resilient spigot packing between sections of hammer frames
- Mounting ancillary equipment on heavy plant to attenuate vibration and improve operator comfort
- Prevent fretting, corrosion, and spalling of concrete seatings
- TICO PF/WA washers to replace spring washers on tie bolts



FF/PA

This composite material is intended for arduous shock absorbing applications, for example as buffers on counter blow hammers and mine cages. The properties of TICO FF/PA can be varied to suit demands by altering the proportions of the individual layers in the material.

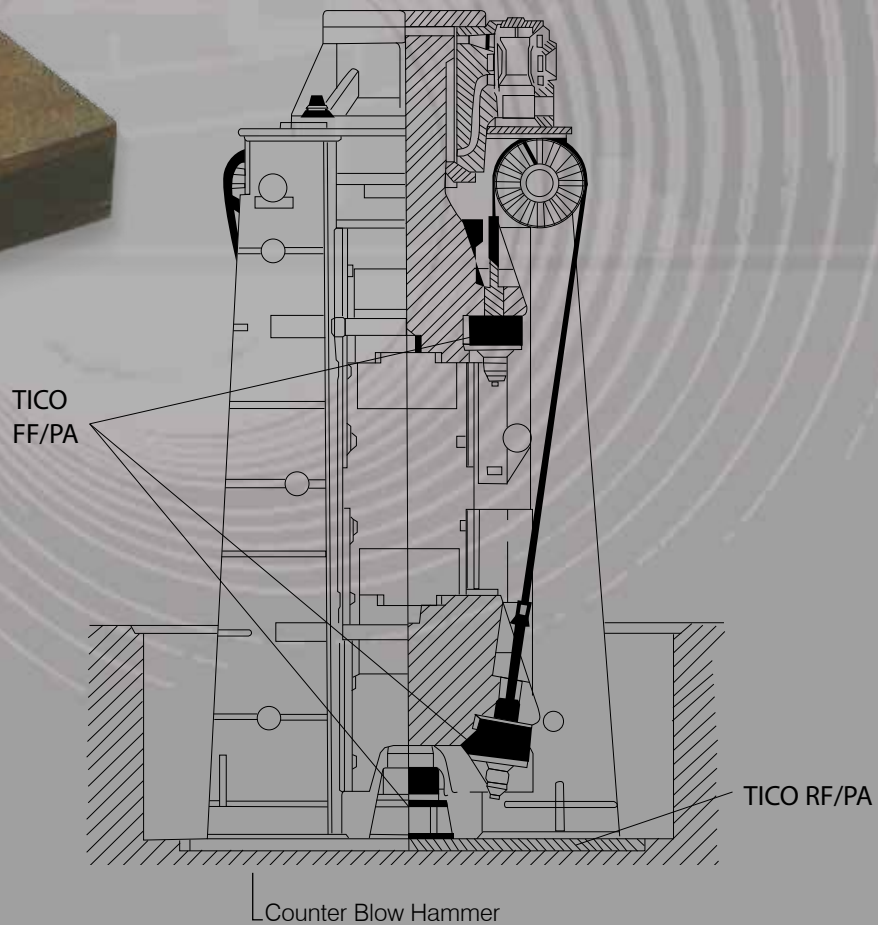

TICO FF/PA utilises TICO PF/PA material, firmly bonded to a layer of synthetic rubber modified with cellular particles. The elastomeric layer may also take the form of a sandwiched interply for increased resilience. As a face layer, this will absorb seating irregularities to give an even location of the pad as a whole.

Typical Applications

- Forging hammer buffer pads
- Resilient pads for roller table bearing chocks
- End stop buffers in steelworks
- Buffers for mine cages
- Mounting high-load machines on irregular surfaces



Supply

Code	Product	Standard Thickness mm	Standard Size mm
TICO RF/PA	Hi-Duty Material	6 (1/4")	1,200 (4') x 1,200 (4')
		12.5 (1/2")	1,200 (4') x 1,200 (4')
		19 (3/4")	1,200 (4') x 1,200 (4')
		25 (1")	1,200 (4') x 1,200 (4')
TICO PF/PA	Hi-Duty Material Also supplied as washers and custom moulded components	6 (1/4")	1,200 (4') x 1,200 (4')
		12.5 (1/2")	1,200 (4') x 1,200 (4')
		19 (3/4")	1,200 (4') x 1,200 (4')
		25 (1")	1,200 (4') x 1,200 (4')
TICO FF/PA	Hi-Duty Materia	6 (1/4")	1,200 (4') x 1,200 (4')
		12.5 (1/2")	1,200 (4') x 1,200 (4')
		25 (1")	1,200 (4') x 1,200 (4')

Adhesives

The following standard products are available for use with TICO Hi-Duty resilient mounting materials.

TICO Contact S Adhesive	General Purpose	1 litre (0.264 US Gal) 5 litre (1.32 US Gal)	Approx. coverage 4 m ² /litre
TICO A/ST Sealing Tape	Sealing Tape	74 mm (3") wide x 50 m roll	
TICO VF/PA	Void Filler	1200 x 600 x 12.5 mm 1200 x 600 x 25 mm	Pack of 10 sheets Pack of 5 sheets
TICO Marine Epoxy (two parts)	Epoxy Resin	600 g	Approx. coverage 1 m ²

Storage

On arrival on site, TICO Hi-Duty material should be very carefully stored in a cool dry place, away from direct sunlight, excessive heat, chemical or any liquid media.

For a full recommendation on storage please refer to ISO 2230.

Safe Handling data sheets are available for all TICO products on request.



Technical

RF/PA

Property	Characteristic	Explanation
Load Bearing Capacity	7 MN/m ² (1000 lbf/in ²) 23.5 MN/m ² (3400 lbf/in ²)	Recommended maximum stress Average ultimate stress at breakdown
Hardness (ISO 48)	83 ± 5 °	International Rubber Hardness Degrees
Coefficient of Friction	0.5 0.7 0.6 0.7	Fabric surface to bright mild steel Fabric surface to concrete TICO S to bright mild steel TICO S to concrete
Temperature Range	*-40 °C to +70 °C	*For static applications only. -30 °C is the minimum temperature for dynamic applications
Lateral Spread	Stress Average Lateral Spread 3.5 MN/m ² 1% (500 lbf/in ²) 7.0 MN/m ² 2.1% (1000 lbf/in ²)	A pad exhibited these characteristics under compression
Average Loss Factor	0.14	

Please contact our Customer Services Department with full details of your requirements for a free written quotation. Our Technical Department will also be pleased to assist you in determining your exact requirements.

All TICO materials are manufactured in accordance with BS EN 9001:2000.

PF/PA FF/PA

Property	Characteristic TICO PF/PA	TICO FF/PA	Explanation
Load Bearing Capacity	15.5 MN/m ² (2240 lbf/in ²) 68.2 MN/m ² (9890 lbf/in ²)	15.5 MN/m ² (2240 lbf/in ²) 68.2 MN/m ² (9890 lbf/in ²)	Recommended maximum stress Average ultimate stress at breakdown
Hardness (ISO 48)	95 ± 5 °	95 ± 5 ° - Fabric Surface 80 ± 5 ° - Face Layer Surface	International Rubber Hardness Degrees
Coefficient of Friction	0.6 0.8	0.6 0.8 0.8 0.7	Fabric surface to bright mild steel Fabric surface to concrete Face layer to bright mild steel Face layer to concrete
Temperature Range	*-40 °C to +80 °C	*-40 °C to +80 °C	*For static applications only. -30 °C is the minimum temperature for dynamic applications



Tiflex Limited, Tiflex House, Liskeard, Cornwall, PL14 4NB, UK

Tel: +44 (0) 1579 320808 Fax: +44 (0) 1579 320802

Email: tico@tiflex.co.uk

Web: www.tiflex.co.uk

James Walker



Uniclass L53912	EPIC E48
CI/SIB (43.9) X (J6)	