

## HIGH PERFORMANCE SEALING SOLUTIONS



# Corporate Overview

**Fluorocarbon is one of the UK's largest fluoropolymer processors and a global supplier of PTFE, polymer related components and semi-finished materials.**

**Many of our customers are worldwide market leaders across many business sectors, which is why we ensure our range of products and services are focused on meeting their increasing demands.**

## Worldwide Resources

- 5 manufacturing sites: 4 in the UK and 1 in Europe
- Sales offices in Europe and the USA
- Partners globally
- Design and development facilities

## Products

Our expertise in design & development and commitment to first-rate customer service has created global appeal for our extensive range of products, which include:

- Seals
- Hoses
- Fluoroglide® slide bearings, Pipe Supports and Skidways
- PU & rubber finished products
- Valve seats
- Semi-finished materials (melt fluoropolymers, PTFE rod, tube, sheet and tape)
- Machined components
- Moulded components
- High performance surface coatings
- Industrial bakeware

## Services

- Cleaning and gritblasting
- Etching and bonding

## Competitive advantage

We aim to offer our customers, cost effective solutions at the highest quality from material selection through to product design, manufacturing and distribution.

We have a group research and development team bringing new materials and products to market, and our modern, qualified laboratories offer full traceability on all products, other advantages include:

- A quality system certified to ISO 9001:2008
- Supply against discreet requirements or scheduled demands such as Kanban and Just-In-Time.
- Support for APQP and PPAP submission of products
- Testing and analysis to International Standards including - ASTM, DIN, BSI and ISO
- Testing includes - tensile, elongation, density, hardness, zero strength time, peel testing, compression and flexural.

## Fluorinoid® Materials

Based on elastomer, PTFE and thermoplastic technologies, our Fluorinoid® company register includes over 500 materials that offer exceptional characteristics enabling them to operate in demanding environmental conditions at temperatures from -196°C (-320°F) to over 300°C (572°F).

One of the UK's largest fluoropolymer processors and a global supplier of PTFE, polymer related components and semi-finished materials.



Introduction

# Contents

Description	Page Number
Bespoke Services	Page 2
Materials	Page 3
Product Range	Page 4
Rubber Energised PTFE Piston and Rod Seals	Page 5
F100 Seals	Page 5
F200 Seals	Page 6
F300 Seals	Page 7
F400 Wiper Rings	Page 8
'U' Spring Energised PTFE Piston and Rod Seals	Page 9
F500 Seals	
Coil Spring Energised PTFE Piston and Rod Seals	Pages 10 - 11
F600 Seals	Page 10
F610 Seals	Page 11
Coil Spring Energised PTFE Face Seals	Page 12
F650 Seals	
High Pressure Sealing Performance	Page 13
'U' Spring Energised PTFE Rotary Shaft Seals	Page 14
F700 Seals	
Fluoroglide® PTFE Bearing Strips	Page 15
F800 Bearing Strips	
PTFE Rotary Shaft Seals	Pages 16 - 17
Metal Sealing Rings	Pages 18
Installation Details	Pages 19
Notes	Page 20
Application Data Sheet	Page 21

What We Do

## Bespoke Service

Fluorocarbon Ltd is a global supplier of high performance fluid handling products such as seals and hoses, designed to meet the demanding applications of aerospace, energy, automotive, pharmaceutical, medical and many others, including the sub-market supply chain.

Many of the seals in this catalogue are designed to suit industry standard grooves and assemblies, however, we also provide bespoke solutions in both product design and material specification.

Our commercial and design engineers have many combined years of product design experience, working with our customers engineering team, to ensure the product meets or exceeds the requirements of the application.

Support from the Fluorocarbon Group ensures we have the latest material developments available. In addition to usual testing for material specification, many applications can be replicated for tribological testing.



### Case Histories

**Low Friction Seats and Stem Seals**  
Through extensive material development, Fluorocarbon has introduced a low friction seat material, with low water absorption and cold flow rates reducing torque figures throughout valve life.

**Welded Ball Valves**  
Large diameter welded ball valves can suffer from large body cavity expansion at high pressures. This creates higher than normal clearances and extrusion gaps, so Fluorocarbon designed a seal configuration which allows float of the anti-extrusion device, reducing the likelihood of material flow under pressure. At lower pressures the anti-extrusion device is stowed and does not impede the cavity contraction.

**Transmission Seals**  
Working with our customer on a new product development, Fluorocarbon designed a range of rotary shaft seals for the driveline of semi-amphibious military vehicles. All specially designed and developed to retain the transmission fluids, but also to prevent dirt and water ingress.

**Drinks Dispenser**  
Following a number of unscheduled engineer call outs, Fluorocarbon was contacted to review and improve the seal arrangement on an OEM drinks dispenser. We developed a new aftermarket seal configuration and material which improved seal efficiency and increased service call schedules from 6 months to 12 months.

**Bias Drill Transport Sleeve**  
Fluorocarbon were approached to improve a current 'clam-shell' bias unit protector, which had issues regarding product quality, re-usability and function. The resultant product was better quality, could be re-used and allowed a narrow range of product to be used on a wider range of units, resulting in lower unit prices.

Fluorocarbon have been awarded **NORSOK M-710** approval for 10 of our Fluoronoid® materials

Our Range

# Materials

## Standard PTFE Materials

### Fluorinoid® PTFE Compounds

Fluorocarbon's Fluorinoid® PTFE materials are renowned for their chemical inertness to almost all known industrial chemicals and are suitable for continuous temperatures of up to 260°C dependent on pressure. Limitations for use are restricted to the molten alkali materials, fluorine and strong fluorinating agents.

Our extensive resources enable us to offer unrivalled experience of PTFE materials technology when applied to sealing systems. The table below details the recommended Fluorinoid® materials for energised seals and bearing strips.

Code	Description	Properties / Application
100	Virgin PTFE	Almost a universal chemical resistance over a wide temperature range with unique low friction and anti-stiction properties. More prone to creep and abrasion than filled grades. Suitable for food applications.
114	Carbon/Graphite filled PTFE	Good bearing material with excellent resistance to wear and creep.
115	Carbon filled PTFE	Good bearing material with excellent resistance to wear and creep.
117	Ekonal® filled PTFE	Polymer filler provides good physical properties which can be used with non-hardened running surfaces.
123	Graphite filled PTFE	Good material for bearing applications with limited lubrication.
141	Bronze filled PTFE	Standard bearing material with excellent resistance to wear and creep.
148	Bronze filled PTFE	Standard material for oil hydraulics with excellent resistance to wear and creep. Chemical resistance is limited to that of the bronze filler.
151	PTFE with special additives	General purpose low friction material with good resistance to abrasion and creep.
156	Carbon filled PTFE	Good resistance to wear and creep under load.
158	Glass / Molybdenum filled PTFE	This combination of fillers offers excellent physical properties with good resistance to creep and abrasion. Requires harder running surfaces to minimise wear.
159	Glass Filled PTFE with special additives	General grade of PTFE with glass fibre and other fillers. Offers excellent physical properties with good resistance to abrasion and creep. Requires harder running surfaces than other PTFE grades.

## Spring Energiser Material

For general use, spring energised seals are fitted with springs manufactured from stainless steel 301/302. Other materials are available and their properties and applications are listed below.

Code	Description	Properties / Application
V	Stainless steel 301/302	General purpose application. Good corrosion resistance. 301 used for smaller springs.
W	Nickel-chromium alloy UNS N10276 (eg Hasteloy® C-276)	Excellent resistance to localised forms of attack by hot contaminated mineral acids, solvents, chlorine and chlorine contaminated acids. NACE approved.
X	Cobalt-nickel-chromium-molybdenum alloy UNS R30003 (eg Elgiloy®)	Excellent corrosion resistant alloy with high strength and good mechanical properties, even at elevated temperatures. Widely used in the oil industry. NACE approved.
Y	Nickel-chromium alloy UNS N07750 (eg Inconel® X750)	Excellent corrosion resistance. Widely used in petrochemical applications. NACE approved.
Z	Double spring cobalt-nickel-chromium-molybdenum alloy UNS R30003	Excellent corrosion resistant alloy with high strength and good mechanical properties. Widely used in the oil industry. Double spring typically used in cryogenic applications. NACE approved.

Other spring materials are available upon request, subject to availability.

## Rubber Energiser Material

The following elastomers are recommended for the standard range of rubber energised seals.

Code	Description	Properties / Application
E	Ethylene Propylene/EP	A rubber with excellent resistance to ozone, weathering, water and steam. Good high and low temperature capability (-40°C to +150°C) with excellent resistance to set.
F	Fluoroelastomer/ Viton®	High temperature capability (-15°C to 220°C) and excellent resistance to hydraulic oils, petrol and many chemicals.
N	Nitrile/Buna-N®	Excellent resistance to mineral based fluids. Strength, resilience, abrasion and heat resistance are reasonable (-40°C to +120°C).
P	Polychloroprene/ Neoprene®	Good resistance to weathering, (crazing and cracking). Good high and low temperature properties (-35°C to +110°C).
S	Silicone	Can be used at extremes of temperature (-60°C to +220°C). Excellent chemical and weathering resistance. Widely used in the medical field due to its non-toxicity.



Our Range

# Product Range

## F100

Double acting rubber energised PTFE piston and rod seals for reciprocating hydraulic and pneumatic applications.

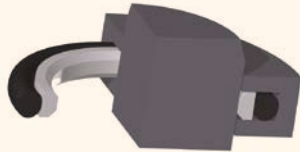

## F500

Single acting spring energised PTFE piston and rod seals for high performance applications where rubber energisers would not be suitable.

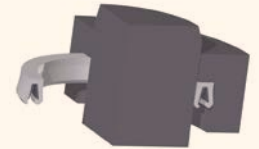

## F200

Double acting rubber energised PTFE piston and rod seals designed to replace standard 'O' rings in order to reduce friction and extend service life.

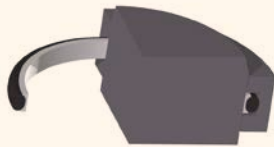

## F600

Coil spring energised PTFE seals for high pressure low speed/static applications.

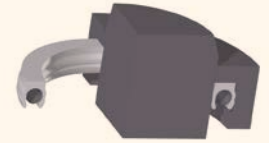

## F300

Single acting rubber energised PTFE piston and rod seals for low friction reciprocating hydraulic and pneumatic applications.

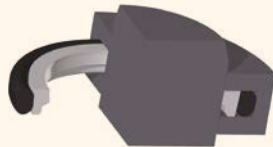

## F700

Spring energised PTFE rotary shaft seals.

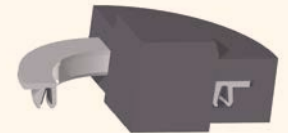

## F400

Rubber energised PTFE wiper ring designed to prevent ingress of dust and moisture into hydraulic and pneumatic systems.



## F800

Fluoroglide® PTFE bearing strips.

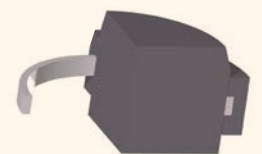



Our Range

# Rubber Energised PTFE Piston and Rod Seals

## F100 Seals

F100 rubber energised PTFE piston and rod seals can be used in both single and double acting applications. This simple robust seal is particularly suited to reciprocating hydraulic and pneumatic applications.

### Operating Range

F100 seals can operate at pressures of up to 380 bar (5510 psi) in dynamic applications and 750 bar (10875 psi) in some static applications. Operating temperatures can range from -60°C to +220°C (-76°F to +428°F) depending on the materials selected.

The seals can operate at linear surface speeds of up to 12m/sec depending upon application conditions.

### Recommended PTFE Materials

- Fluorinoid® 148 (Bronze filled PTFE)
- Fluorinoid® 151 (PTFE with Special Additives)
- Fluorinoid® 114 (Carbon/Graphite filled PTFE)
- Fluorinoid® 159 (Glass filled PTFE with Special Additives)

## Installation Details

### F100B Piston Seal

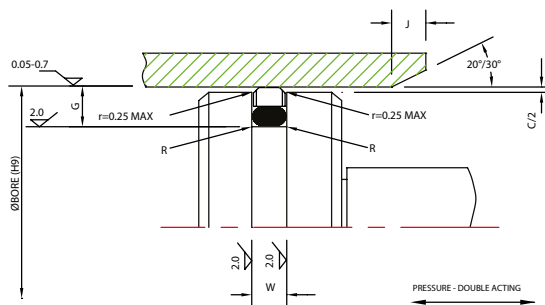

### F100R Rod Seal

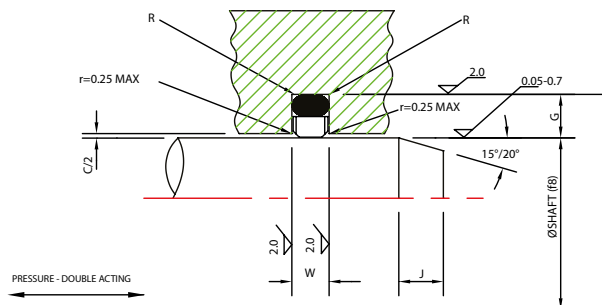

G	W	Max Diametrical Clearance 'C'		R Max	J Min
		+0.25 -0.00	0-190 BAR		
2.50	2.25	0.6	0.4	0.4	1.5
3.75	3.30	0.7	0.5	0.7	2.5
5.50	4.25	0.8	0.5	1.3	3.0
7.75	6.35	0.9	0.6	1.5	5.0
10.50	8.20	1.0	0.6	2.0	6.0
12.25	8.20	1.2	0.7	2.0	6.0
14.00	9.65	1.4	0.7	2.5	7.0

Our Range

# Rubber Energised PTFE Piston and Rod Seals

## F200 Seals

F200 rubber energised PTFE seals are designed to replace conventional 'O' rings in existing installations, in order to reduce friction and improve service life. They can be used for both single and double acting reciprocating applications.

The F200 seal comprises a PTFE ring and a standard 'O' ring energiser. The PTFE ring is shaped to hold the 'O' ring in position and prevent extrusion.

## Operating Range

F200 seals can operate at pressures of up to 340 bar (4930 psi) and temperatures ranging from -60°C to +220°C (-76°F to +428°F) depending on the materials selected.

The seals can operate at surface speeds of up to 12m/sec depending upon application conditions.

## Notes on Selection

F200 seals can be used to replace standard 'O' ring seals with up to two anti-extrusion rings.

## Recommended PTFE Materials

Fluorinoid® 151 (PTFE with Special Additives)

Fluorinoid® 156 (Carbon filled PTFE)

G	W +0.25 -0.00	Max Diametrical Clearance 'C'	R Max	J Min
1.45	2.45	0.12	0.4	2.0
2.25	3.55	0.18	0.4	2.9
3.10	4.80	0.20	0.6	3.9
4.70	7.20	0.24	0.8	5.7
6.10	9.50	0.28	0.8	7.6

## Installation Details

### F200B Piston Seal

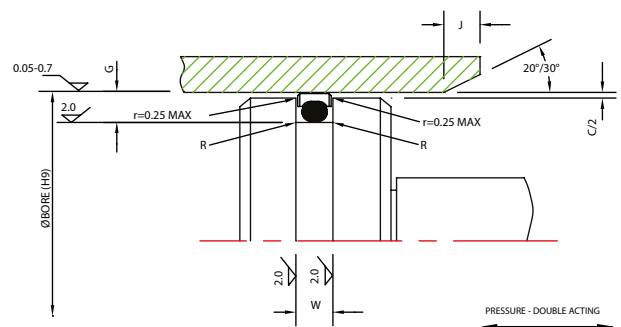

### F200R Rod Seal

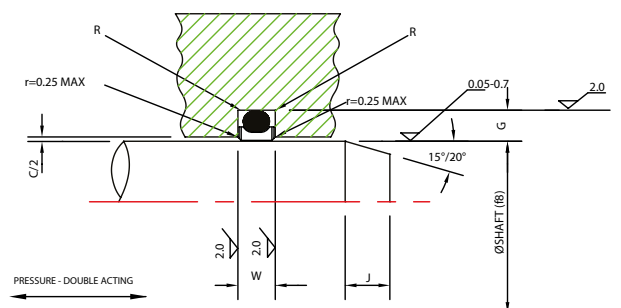

### F300 Seals

F300 rubber energised PTFE piston and rod seals can be used in single acting hydraulic and pneumatic cylinders. The PTFE ring has a cross section which minimises friction and provides an effective wiper seal.

### Operating Range

F300 seals can operate at pressures of up to 380 bar (5510 psi) in dynamic applications and 750 bar (10875 psi) in some static applications. Operating temperatures can range from -60°C to +220°C (-76°F to +428°F) depending on the materials selected.

The seals can operate at surface speeds up to 15m/sec depending upon application conditions.

### Recommended PTFE Materials

- Fluorinoid® 114 (Carbon/Graphite filled PTFE)
- Fluorinoid® 148 (Bronze filled PTFE)

G	W +0.25 -0.00	Max Diametrical Clearance 'C'		R Max	J Min
		0-190 BAR	190-380 BAR		
2.50	2.25	0.6	0.4	0.4	1.5
3.75	3.30	0.7	0.5	0.7	2.5
5.50	4.25	0.8	0.5	1.3	3.0
7.75	6.35	0.9	0.6	1.5	5.0
10.50	8.20	1.0	0.6	2.0	6.0
12.25	8.20	1.2	0.7	2.0	6.0
14.00	9.65	1.4	0.7	2.5	7.0

### Installation Details

F300B Piston Seal

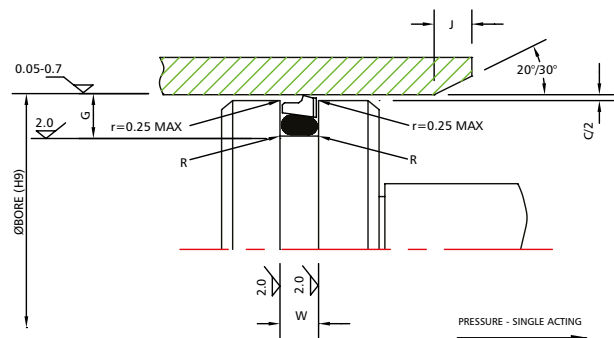

F300R Rod Seal

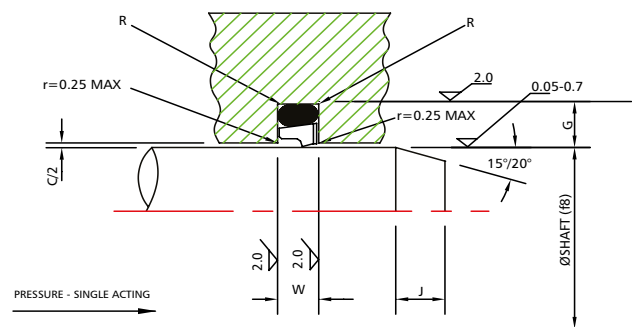

Our Range

# Rubber Energised PTFE Wiper Rings

## F400 Wiper Rings

F400 rubber energised PTFE wiper rings are designed to act on reciprocating piston rods and plungers to prevent the ingress of dust and moisture etc into hydraulic and pneumatic systems.

## Operating Range

F400 wiper rings can operate at temperatures ranging from -60°C to +220°C (-76°F to +428°F) depending on the materials selected. The wiper rings can operate at surface speeds of up to 16m/sec depending upon application conditions.

## Recommended PTFE Materials

- Fluorinoid® 114 (Carbon/Graphite filled PTFE)
- Fluorinoid® 148 (Bronze filled PTFE)
- Fluorinoid® 151 (PTFE with Special Additives)
- Fluorinoid® 159 (Glass filled PTFE with Special Additives)

## Installation Details

### F400R Wiper Ring

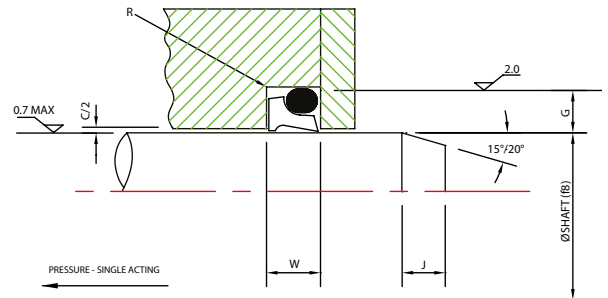

G	W <sup>+0.25</sup> <sub>-0.00</sub>	Max Diametrical Clearance 'C'	X Max	R Max	J Min
2.5	4.0	2.0	1.7	0.4	2.6
3.5	5.0	3.0	2.4	0.7	3.5
4.5	6.0	3.5	3.2	1.0	4.2
6.0	8.5	4.0	4.5	1.2	5.9
8.0	11.0	5.0	5.5	1.5	7.7
10.0	14.0	6.0	6.0	2.0	9.8



Our Range

# “U” Spring Energised PTFE and Rod Seals

## F500 Seals

F500 ‘U’ spring energised piston and rod seals are designed for single acting, high performance, reciprocating applications.

### Operating Range

F500 seals can typically operate at pressures of up to 340 bar (4930 psi). Operating temperatures range from -80°C to +260°C (-112°F to +500°F).

For reciprocating applications, the seals can operate at surface speeds of up to 14m/sec. The seals can also be used for slowly rotating and oscillating applications with surface speeds up to 1m/sec.

### Recommended PTFE Materials

- Fluorinoid® 100 (Virgin PTFE)
- Fluorinoid® 117 (Ekonal® filled PTFE)
- Fluorinoid® 158 (Glass/Molybdenum filled PTFE)
- Fluorinoid® 148 (Bronze filled PTFE)
- Fluorinoid® 151 (PTFE with Special Additives)
- Fluorinoid® 156 (Carbon filled PTFE)
- Fluorinoid® 159 (Glass filled PTFE with Special Additives)

### Recommended Spring Materials

- Stainless Steel 301/302
- Cobalt-Nickel-Chromium-Molybdenum Alloy
- UNS R30003 (eg Elgiloy®)

## Installation Details

### F500B Piston Seal

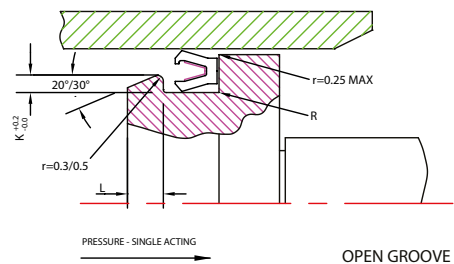
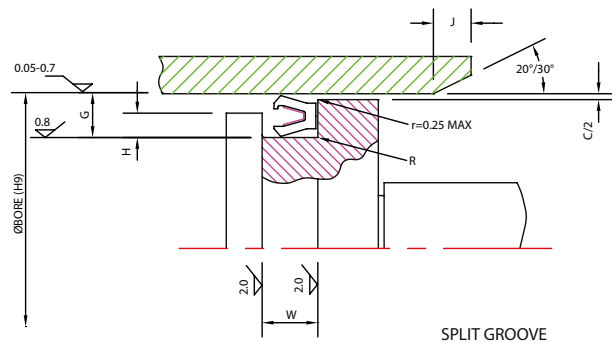

### F500R Rod Seal

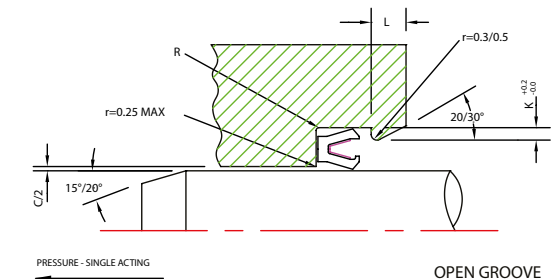
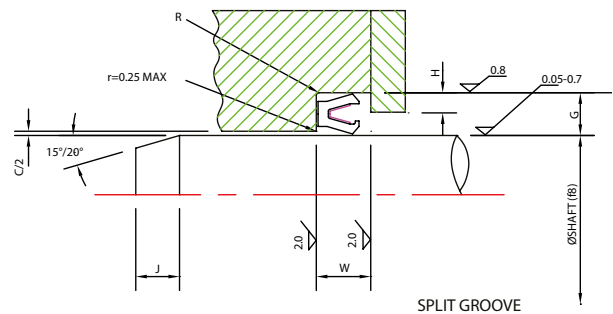

G	W <sup>+0.25</sup> -0.00	Max Diometrical Clearance 'C'	R Max	K	L Min	J Min	H Min
1.45	2.45	0.10	0.35	0.35	2.5	2.5	0.4
2.25	3.6	0.12	0.4	0.5	4.7	2.5	0.6
3.10	4.8	0.15	0.6	0.6	5.5	3.0	0.7
4.70	7.1	0.20	0.8	0.7	5.7	4.5	0.8
6.10	9.5	0.25	0.8	0.8	8.5	6.0	0.9

Our Range

# Coil Spring Energised PTFE Piston and Rod Seal

## F600 Seals

F600 coil spring energised seals are designed for single acting, high pressure, low speed/static applications, and are available for both internal and external fittings.

## Operating Range

F600 seals can typically operate at pressures of up to 690 bar (10000 psi) and temperatures ranging from -196°C to +260°C (-320°F to +500°F). Please consult our design office for wider pressure and temperature ranges.

## Recommended PTFE Materials

Fluorinoid® 148 (Bronze filled PTFE)  
Fluorinoid® 156 (Carbon filled PTFE)

## Recommended Spring Materials

Stainless Steel 301/302  
Cobalt-Nickel-Chromium-Molybdenum Alloy  
UNS R30003 (eg Elgiloy®)



## Installation Details

### F600B Piston Seal

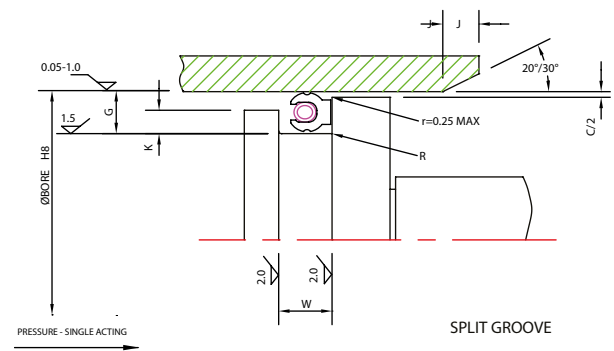

### F600R Rod Seal

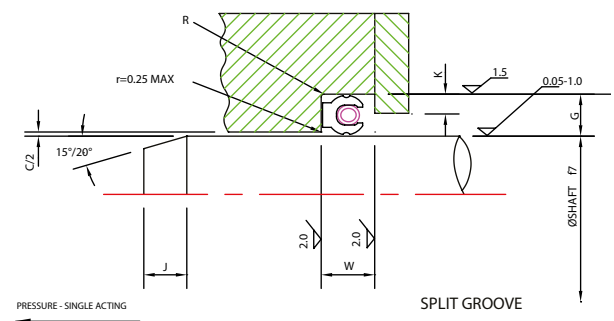

G	W <sup>+0.25</sup> / <sub>-0.00</sub>	R Max	K Min	J Min
1.45	2.45	0.35	0.4	2.5
2.25	3.6	0.4	0.6	2.5
3.10	4.8	0.6	0.7	3.0
4.70	7.1	0.8	0.8	4.5
6.10	9.5	0.8	0.9	6.0

For diametrical clearance (c) see figure 2 on page 13

Our Range

# Coil Spring Energised PTFE Piston and Rod Seals

## F610 Seals

F610 coil spring energised seals are designed for single acting, high pressure, static applications. They are available for both internal and external fittings.

## Operating Range

F610 seals can typically operate at pressures of up to 690 bar (10000 psi). Operating temperatures can range from -196°C to +260°C (-320°F to +500°F).

Please consult our design office for wider pressure and temperature ranges.

## Recommended PTFE Materials

Fluorinoid® 100 (Virgin PTFE)

Fluorinoid® 123 (Graphite filled PTFE)

Fluorinoid® 156 (Carbon filled PTFE)

## Recommended Spring Materials

Stainless Steel 301/302

Cobalt-Nickel-Chromium-Molybdenum Alloy

UNS R30003 (eg Elgiloy®)

## Installation Details

### F610B Piston Seal

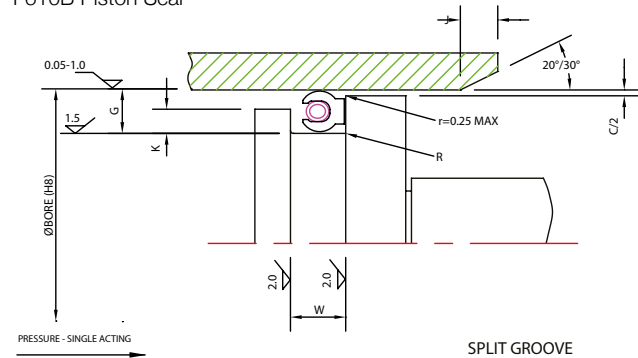

### F610B Rod Seal

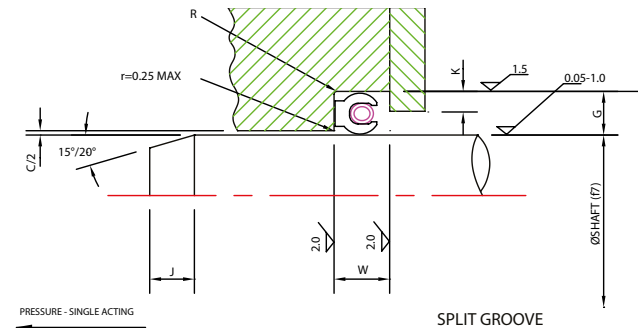

G	W	+0.25 -0.00	R Max	K Min	J Min
1.45	2.45		0.35	0.4	2.5
2.25	3.6		0.4	0.6	2.5
3.10	4.8		0.6	0.7	3.0
4.70	7.1		0.8	0.8	4.5
6.10	9.5		0.8	0.9	6.0

For diametrical clearance (c) see figure 2 on page 13



Our Range

# Coil Spring Energised PTFE Face Seal

## F650 Seals

F650 coil spring energised seals are designed for single acting, high pressure, static applications. They are available for both internal and external fittings.

## Operating Range

F650 seals can typically operate at pressures of up to 690 bar (10000 psi) and temperatures ranging from -196°C to +260°C (-320°F to +500°F).

Please consult our design office for wider pressure and temperature ranges.

## Recommended PTFE Materials

- Fluorinoid® 100 (Virgin PTFE)
- Fluorinoid® 123 (Graphite filled PTFE)
- Fluorinoid® 156 (Carbon filled PTFE)

## Recommended Spring Materials

- Stainless Steel 301/302
- Cobalt-Nickel-Chromium-Molybdenum Alloy
- UNS R30003 (eg Elgiloy®)

## Installation Details

F650I Seal

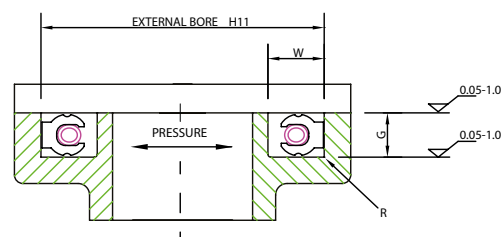

F650E Seal

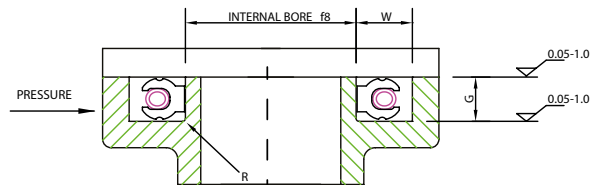

G	TOL on G	W +0.25 -0.00	R Max
1.45	+0.02 -0.03	2.45	0.35
2.25	+0.02 -0.03	3.6	0.4
3.10	+0.02 -0.03	4.8	0.6
4.70	+0.02 -0.04	7.1	0.8
6.10	+0.02 -0.04	9.5	0.8
9.30	+0.02 -0.04	13.1	0.8



Our Range

# High Pressure Sealing Performance

## Extrusion Gaps and Anti-extrusion Rings

When sealing at elevated temperatures and pressures, the amount of clearance between the opposing piston and housing, behind the seal, becomes critical. This clearance is termed the extrusion gap.

High pressure, particularly in combination with elevated temperature, can cause the seal to extrude into the clearance and cause premature failure. Extrusion gaps should always be kept to a reasonable minimum, and should not exceed the values shown in figure 2.

By modifying the heel of the seal or incorporating anti-extrusion rings, as shown, larger extrusion gaps are acceptable.

The anti-extrusion ring is generally of a material with a higher flexural modulus like PEEK but can also be supplied in metals if required.

The seal can also be supplied with a profiled angled heel and a single angled anti-extrusion ring. This allows the anti-extrusion ring to float radially within the housing. This is particularly useful in applications where the applied pressure causes a swelling of the housing, which is evident in some large diameter welded valves and connectors.

For larger extrusion gaps or extremes of pressure and temperature please contact our design office.

Groove width must be increased to accommodate these anti-extrusion devices (See figure 3).

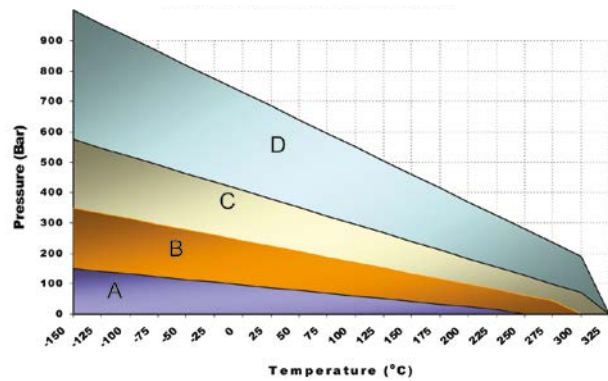

Figure 1, Temperature/Pressure Chart

	Material	A	B	C	D
1	Virgin PTFE	0.10	0.075	0.05	n/a
	Filled PTFE	0.15	0.10	0.075	n/a
2	Virgin PTFE	0.15	0.10	0.075	n/a
	Filled PTFE	0.20	0.15	0.10	0.075
3	Virgin PTFE B/U	0.20	0.15	0.10	0.075
	PEEK B/U	0.25	0.20	0.15	0.10
4	Filled PTFE	0.25	0.20	0.15	0.10
	PEEK B/U	0.35	0.25	0.20	0.15

Figure 2, Radial Clearance (mm)

C/S	W			
	1	2	3	4
1.45	2.45	4.15	5.6	5.6
2.25	3.6	5.0	6.7	6.7
3.1	4.8	6.3	8.1	8.1
4.7	7.1	9.1	11.5	11.5
6.1	9.5	12.0	15.5	15.5

Figure 3, Groove width dimensions required (mm)



Our Range

# 'U' Spring Energised PTFE Rotary Shaft Seals

## F700 Seals

F700 'U' spring energised PTFE seals are designed for single acting rotary applications. They are particularly useful for small diameter shafts and where groove size is limited.

## Operating Range

F700 rotary shaft seal can operate at surface speeds of up to 15m/sec, however the maximum operating pressure is dependent on the rotational speed. Operating temperatures can range from -80°C to +200°C (-112°F to +392°F).

## Recommended PTFE Materials

- Fluorinoid® 117 (Ekonal® filled PTFE)
- Fluorinoid® 158 (Glass/Molybdenum filled PTFE)
- Fluorinoid® 156 (Carbon filled PTFE)

## Recommended Spring Materials

- Stainless Steel 301/302
- Cobalt-Nickel-Chromium-Molybdenum Alloy
- UNS R30003 (eg Elgiloy®)

## Installation Details

F700 Rotary Shaft Seal

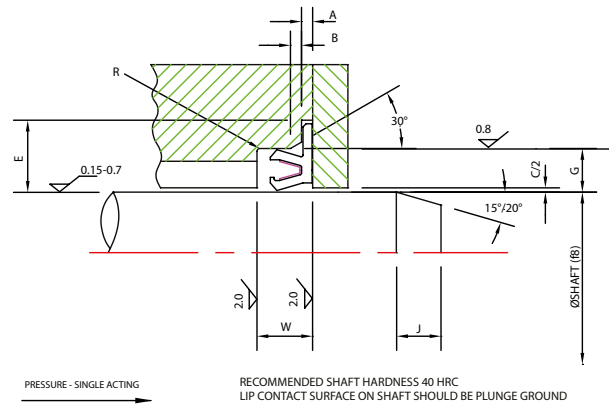

G	W	+0.20 -0.00	Max Diametrical Clearance 'C'	R Max	A	+0.0 -0.1	B	+0.2 -0.0	E Min	J Min
2.25	3.6		0.13	0.4	0.75		0.9		6.5	3.4
3.10	4.8		0.15	0.6	1.00		1.0		7.0	3.4
4.70	7.1		0.17	0.8	1.50		1.3		10.0	3.7
6.10	9.5		0.25	0.8	2.00		1.5		11.0	7.5

Our Range

# Fluoroglide® PTFE Bearing Strips

## F800 Bearing Strips

Fluoroglide® PTFE bearing strips are used to guide pistons and piston rods in hydraulic and pneumatic cylinders to prevent metal-to-metal contact. Seal life is considerably improved when bearing strips are installed adjacent to PTFE piston and rod seals by ensuring concentricity and damping vibrations.

F800 Fluoroglide® bearings are available to fit the standard groove sizes detailed and can be manufactured to suit almost any application.

## Operating Range

Fluoroglide® PTFE bearing strips can operate at linear speeds of up to 2m/sec. Operating temperatures can range from -80°C to +260°C (-112°F to +500°F).

## Notes on Installation

The ends of the bearing strips for reciprocating applications are cut at an angle of 60°. Bearing strips for rotary applications are cut square. Special forms are available on request.

## Recommended PTFE Materials

- Fluorinoid® 148/141 (Bronze filled PTFE)
- Fluorinoid® 114 (Carbon/Graphite filled PTFE)
- Fluorinoid® 115 (Carbon filled PTFE)
- Fluorinoid® 123 (Graphite filled PTFE)

## Installation Details

F800B External Acting Bearing Strip

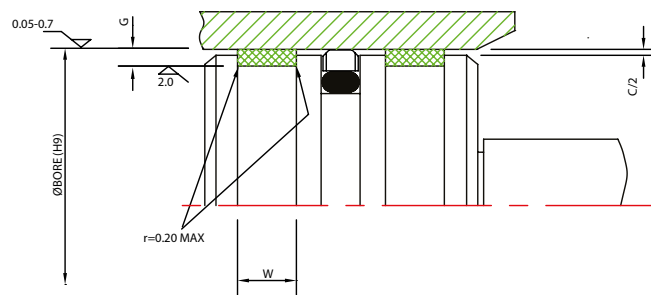

F800R Internal Acting Bearing Strip

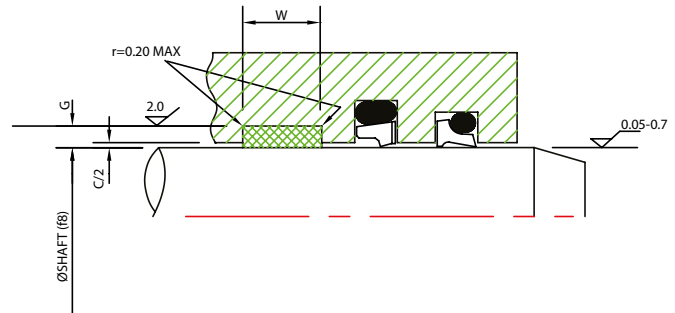

G	W	+0.25 -0.00	Max Diametrical Clearance 'C'
1.5	2.5		0.4
1.5	4.0		0.4
2.5	5.6		0.6
2.5	9.7		0.6
2.5	15.0		0.6
2.5	25.0		0.6



Our Range

## PTFE Rotary Shaft Seals

Fluorocarbon PTFE rotary seals are designed for use in most demanding conditions and offer the following benefits:

- Excellent chemical resistance
- Wide operating temperature range
- Very low coefficient of friction (low torque)
- No stick / slip effect
- High resistance to wear
- Dry run capability
- Very high shaft surface speeds
- Sealing large eccentricities

### Benefits

#### High shaft speeds

Up to 10m/sec can be achieved. These very high surface speeds are subject to lubrication, surface finish and pressure.

#### Dry run

At application start up, seals can be starved of lubrication for brief periods, this is when seal damage is most likely to occur. PTFE, with its ability to microscopically transfer itself to the contact surface of the shaft, prevents high seal wear at this critical dry run period.

#### Low torque (low break-out friction)

Eliminates stiction and seal break-out friction at shaft start-up. Reduces wear, energy and lip temperature, resulting in higher speeds and less risk of oil carbonisation.

#### Shaft eccentricity

PTFE seals are ideally suited to deal with shaft runout and vibration, due to their wide sealing band and lip contact area and the ability to stay with the shaft at high speed when shaft vibration or shaft whip is present.

All configurations are available with hydrodynamic features to improve seal effect, where applications allow.

### Design Types

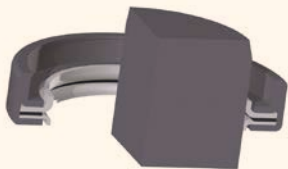

Plain with Dust Lip



Standard Plain Lip

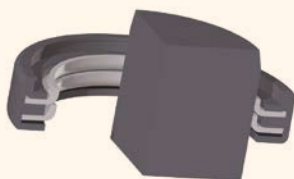

Double Plain Lip

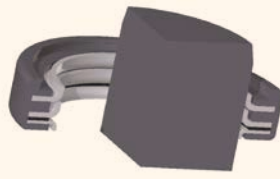

Plain Lips with Dust Lip Excluder

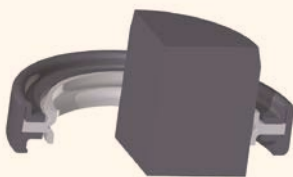

Media Separation Plain Lip



Solid PTFE Design



## Housing and Shaft

### Housing Bore

For full bore and housing size recommendations consult Fluorocarbon Seal Design Department.

Housing tolerance ideally should be held to H8 max, with a surface finish of  $0.8\mu\text{m Ra}$  (32 microinch). Housing lead-in chamfers of  $30^\circ$  are required.

### Shafts

The running area for the seal must be plunge ground with a recommended surface finish of  $0.4\mu\text{m Ra}$  (16 microinch).

### Shaft hardness

- 40 Rockwell C (370 brinell) average ideal hardness up to 50 Bar.
- 35 Rockwell C (323 Brinell) is acceptable for lubricated seal lips.
- At higher pressure, 60 Rockwell C (601 Brinell) for lubricated or corrosive media.
- If shafts are hard nickel or chrome plated, a plating thickness of 0.08mm min (0.003ins) is required after grinding.
- Shafts should have a  $30^\circ$  lead-in chamfer without burrs or sharp edges.

## Seal Material

### Metal cased shell material

The seal case material should match the housing material to produce similar coefficients of expansion during temperature cycles to prevent OD leakage. This is not necessary with rubber covered seals as the rubber interface can tolerate expansion differences.

Our range of case materials include the following:

- Stainless Steel
- Aluminium
- Hastelloy
- Cold Rolled Steel
- Titanium
- Inconel

### Sealing Element Materials

Fluorocarbon have over 500 grades of PTFE compounds and other engineering plastics, but the most common grades for rotary seals are filled with:

- Virgin (unfilled)
- Molybdenum
- Graphite
- Carbon
- Glass Fibre
- Polymeric

Fluorocarbon also offer specially processed grades of material to suit any particular application.

### Gasket Materials

A comprehensive range of gasket materials are available, these typically include:

- DuPont™ Viton®
- Nitrile
- Silicone
- EPDM

### Assembly / Installation

Special care should be taken during assembly due to PTFE lip seals having high lip interferences.

Seals can be supplied with their own individual transport/ installation sleeve or a cone shaped assembly mandrel which is more suitable for OEM/production installations when assembling over a shaft.

For high volume production, seals are transported and stacked on cardboard mandrels which protect the sealing lips.



Our Range

# Metal Sealing Rings

Fluorocarbon metal O rings and C rings are designed for static sealing applications in extreme conditions and hostile environments where elastomer or polymer seals cannot be used. They can withstand pressures from high vacuum to 700MPa and temperatures from cryogenic to 1000°C (1832°F).

Metal sealing rings are manufactured from hollow tube or solid wire in a wide range of materials including various grades of Inconel® and stainless steel.

The rings are often plated or coated with soft materials such as gold, silver, nickel or PTFE, which bed into machining grooves to improve sealing performance.



### Type FH Hollow Metal O Rings

Simple hollow metal O ring suitable for medium pressure and vacuum applications. Max pressure: 4MPa



### Type FG Gas Filled Metal O Rings

Gas filled metal O rings are hollow rings, gas filled to give increased resilience at high temperatures above 430°C (805°F). Max pressure: 40MPa



### Type FS Solid Metal O Rings

Solid metal O rings can be used in numerous applications where an economical metal ring is required. Max pressure: 4MPa



### Type FA System Activated Metal O Rings

System activated O rings are hollow metal rings with small holes that allow the tube to be energised by system pressure. High pressure applications up to 700MPa.



### Type FC System Activated Metal C Rings

System activated C rings are also pressure energised and used in medium to high pressure applications up to 400MPa. They require lower compression loadings and provide higher springback than metal O rings.



### Type FE Spring Activated Metal C Rings

Spring energised C rings are spring and system pressure activated. They offer exceptional spring-back, capable of compensating for expansion due to pressure and temperature cycling. Max pressure: 700MPa

## Part Numbering System

FH - E - 00254 - A - 01 - L - 01 - A

### Product Type Code

FH = Hollow Metal O Ring  
FG = Gas Filled Metal O Ring  
FA = System Activated Metal O Ring  
FC = System Activated Metal C Ring  
FS = Solid Metal O Ring  
FE = Spring Energised Metal C

### Ring Pressure Direction

E = External:  
I = Internal

### Ring Diameter (X10)

eg: 00254 - 25.4mm  
NB: Specify ring ID for external pressure and OD for internal pressure.

### Tube Cross Section

A = 0.9mm  
B = 1.6mm  
C = 2.4mm  
D = 3.2mm  
E = 4.0mm  
F = 4.8mm  
G = 6.4mm  
H = As specified

### Wall Thickness

01 = 0.13mm  
02 = 0.15mm  
03 = 0.25mm  
04 = 0.30mm  
05 = 0.36mm  
06 = 0.51mm  
07 = 0.64mm  
08 = 0.81mm  
09 = 1.24mm  
00 = solid wire

### Material

L = Stainless Steel 304  
M = Stainless Steel 316  
N = Stainless Steel 321  
O = Stainless Steel 347  
Q = Inconel® 718  
R = Inconel® 600  
S = Inconel® X-750  
T = Copper

### Plating Material Thickness

01 = Silver 0.03/0.05mm  
02 = Silver 0.05/0.08mm  
03 = Gold 0.01/0.03mm  
04 = Nickel 0.03/0.05mm  
05 = Copper 0.03/0.05mm  
07 = PTFE 0.03/0.05mm  
08 = PTFE 0.05/0.08mm  
09 = As specified  
00 = None

### Heat Treatment

A = 4-hour aging  
B = 16-hour aging  
C = Annealed  
D = None  
E = As specified

Our Range

# Installation Details

## Installation

Metal sealing rings are usually installed between flanges, located in either a groove or counterbore. The groove depth is calculated to ensure correct compression loading of the ring.

Alternatively, the ring can be installed between two flat flanges and located with a support plate. The thickness of the support plate is equal to the groove depth specified.

## Recommended Surface Finish

0.2µm (8µin.) RMS for plated rings in high vacuum (10 ~ 10 torr)

0.4µm (16µin.) RMS for plated rings in gas, vacuum or low viscosity fluids.

0.8µm (32µin.) RMS for plated rings in medium to high viscosity fluids.

0.4µm (16µin.) RMS for unplated rings in medium to high viscosity fluids.

All machining marks on sealing surfaces must be concentric.

## Internal System Pressure

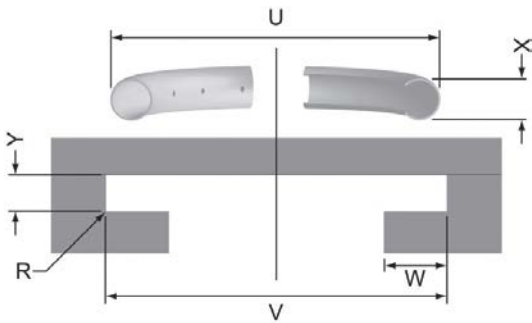

## Internal System Pressure

Tube section 'X'	Ring diameter 'U'	Groove diameter 'V'	O ring groove depth 'Y'	C ring groove depth 'Y'	W min	R max
0.9	6~100	U+0.10/0.15	0.60/0.65	N/A	1.4	0.3
1.6	12~250	U+0.10/0.15	1.05/1.15	1.24/1.30	2.4	0.5
2.4	25~500	U+0.15/0.25	1.65/1.75	1.80/1.96	3.6	0.7
3.2	45~1000	U+0.20/0.30	2.30/2.40	2.46/2.62	4.8	1.0
4.0	70~1500	U+0.20/0.35	2.90/3.05	3.12/3.28	6.0	1.3
4.8	90~2000	U+0.25/0.35	3.70/3.80t	3.75/3.91	7.2	1.6
6.4	120~3000	U+0.30/0.50	4.95/5.05	4.98/5.18	9.6	2.1

## External System Pressure

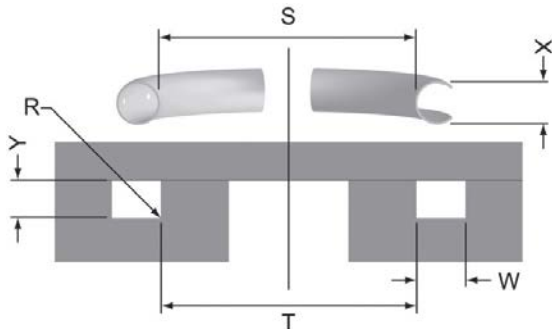

## External System Pressure

Tube section 'X'	Ring diameter 'S'	Groove diameter 'T'	O ring groove depth 'Y'	C ring groove depth 'Y'	W min	R max
0.9	4~100	S-0.10/0.15	0.60/0.65	N/A	1.4	0.3
1.6	8~250	S-0.10/0.15	1.05/1.15	1.24/1.30	2.4	0.5
2.4	20~500	S-0.15/0.25	1.65/1.75	1.80/1.96	3.6	0.7
3.2	40~1000	S-0.20/0.30	2.30/2.40	2.46/2.62	4.8	1.0
4.0	60~1500	S-0.20/0.35	2.90/3.05	3.12/3.28	6.0	1.3
4.8	80~2000	S-0.25/0.35	3.70/3.80	3.75/3.91	7.2	1.6
6.4	100~3000	S-0.30/0.50	4.95/5.05	4.98/5.18	9.6	2.1



Application



# Data Sheet

Please fill in as many details below as possible, this will enable us to recommend the design and materials most suited to your application. Where possible, please include drawings of hardware and/or groove details.

Please send completed form to: Fax: 01992 587 983

Customer:

Address:

Web:

Contact:

Tel:

Fax:

Email:

Application:

Gland Size (mm/inches)\*

OD:  ID:  Width:

Groove details

Open:  Closed:  Split:  Stepped:

Method

Reciprocating:  Radial:  Piston:  Internal Pressure:

Rotary:  Axial (flange):  Rod:  External Pressure:

Application details

Pressure: Max:  Min:  Test (if applicable):

Temperature: Max:  Min:

Media to be sealed:

Speed/Velocity:  (RPM / m/s / ft/min / Hz)\*

Hardware Material 1:  Dynamic surface hardness:

Hardware Material 2:

Quantity required:

Additional notes:  
Please add any notes that will help us to make our recommendation. Including extrusion clearance, eccentricity, guide price, hardware changes, required seal performance etc.

Contacts

C

## Main Contact:

Web: [www.fluorocarbon.co.uk](http://www.fluorocarbon.co.uk)

Email: [info@fluorocarbon.co.uk](mailto:info@fluorocarbon.co.uk)

Fluorocarbon Ltd  
Fluorocarbon Company Ltd  
Fluorocarbon Surface Technologies Ltd

Hertford Office  
Caxton Hill  
Hertford  
Hertfordshire  
SG13 7NH  
United Kingdom  
Tel: +44 (0)845 250 5100  
Fax: +44 (0)845 250 5101

---

### Fluorocarbon Company Ltd FBS Prestige Ltd

Manchester Office  
Fluorocarbon Company Ltd  
Northbank Industrial Park  
Excalibur Way  
Irlam  
Manchester  
M44 5DL  
United Kingdom  
Tel: +44 (0)161 777 6300  
Fax: +44 (0)161 776 2503/7

### Fluorocarbon Surface Technologies Ltd

Sheffield Office  
Birley Vale Avenue  
Sheffield  
S12 2AX  
United Kingdom  
Tel: +44 (0)114 253 0353  
Fax: +44 (0)114 253 0355

### FBS Prestige Ltd

Nottingham Office  
Unit B  
Lilac Grove  
Beeston  
Nottingham  
NG9 1PF  
United Kingdom  
Tel: +44 (0)845 250 5400  
Fax: +44 (0)845 250 5401

### Fluorocarbon Polymers SRL FBS Prestige SRL

European Sales Office  
SC Fluorocarbon SRL  
Strada Dunarii Nr. 277, Corp C10  
Alexandria  
Judetul Teleorman  
Romania  
Tel: +40 247 306170 /314245  
Fax: +40 247 421076

### Fluorocarbon Inc.

USA Sales Office  
Fluorocarbon Inc  
13831 N W Fwy, #407  
Houston  
TX 77040  
USA  
Tel: +1 832 426 4296

The Fluorocarbon trademark is the intellectual property of The Fluorocarbon Group. The following trademarks are the intellectual property of The Fluorocarbon Group. Fluorinoid®, Fluoroglide®, Fluoroflex®, Fluoroetch®, F-LON®  
FCL-SB-010 Issue 6



**FLUOROCARBON**