

Freewheel chain  
adjusting mechanism

Easy to maintain  
Corrosion resistant  
and long-lasting

Nickel plated load chain  
grade 100 (V) (1000 N/mm<sup>2</sup>),  
in accordance with standard  
EN 818-7

Hook latch with safety tip



Options: Carrying case for Model LX003

Dimensions  
(mm)

	LX003	LX005
a	90,5	102,0
b	73,5	93,0
C	205,0	246,0
D	150,0	180,0
e	62,0	68,0
g	21,0	24,5
s	32,0	35,5
t	11,0	12,0

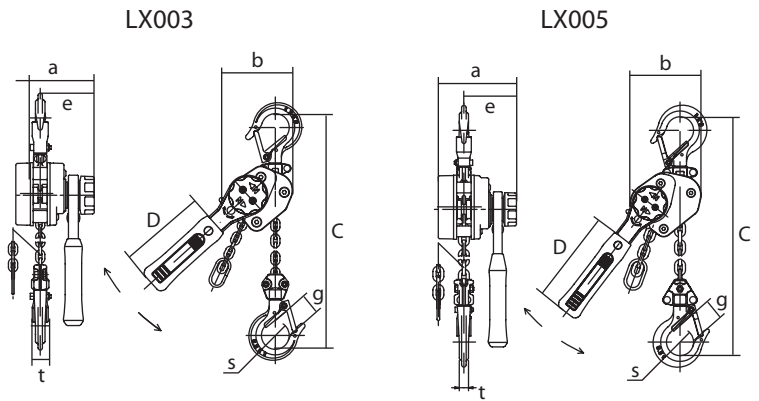

Technical data		
Type	LX003	LX005
Capacity, kg	250	500
Standard lift, m	1,5	1,5
Hand pull to lift full load, daN	20	31
Load chain diameter, mm	3,2 x 9,0	4,3 x 12,0
Chain fall	1	1
Net weight, kg	1,7	2,7
Test weight, kg	380	750
Weight for additional 1 m lift, kg	0,2	0,4

Disclaimer:  
KITO does not assume liability for inappropriate usage of products.  
Operating instructions must be followed at all times.  
Subject to technical change, misprint and errors.

Contact  
[sales@rriuk.com](mailto:sales@rriuk.com)