

Möbilis MOBILE SHELVING

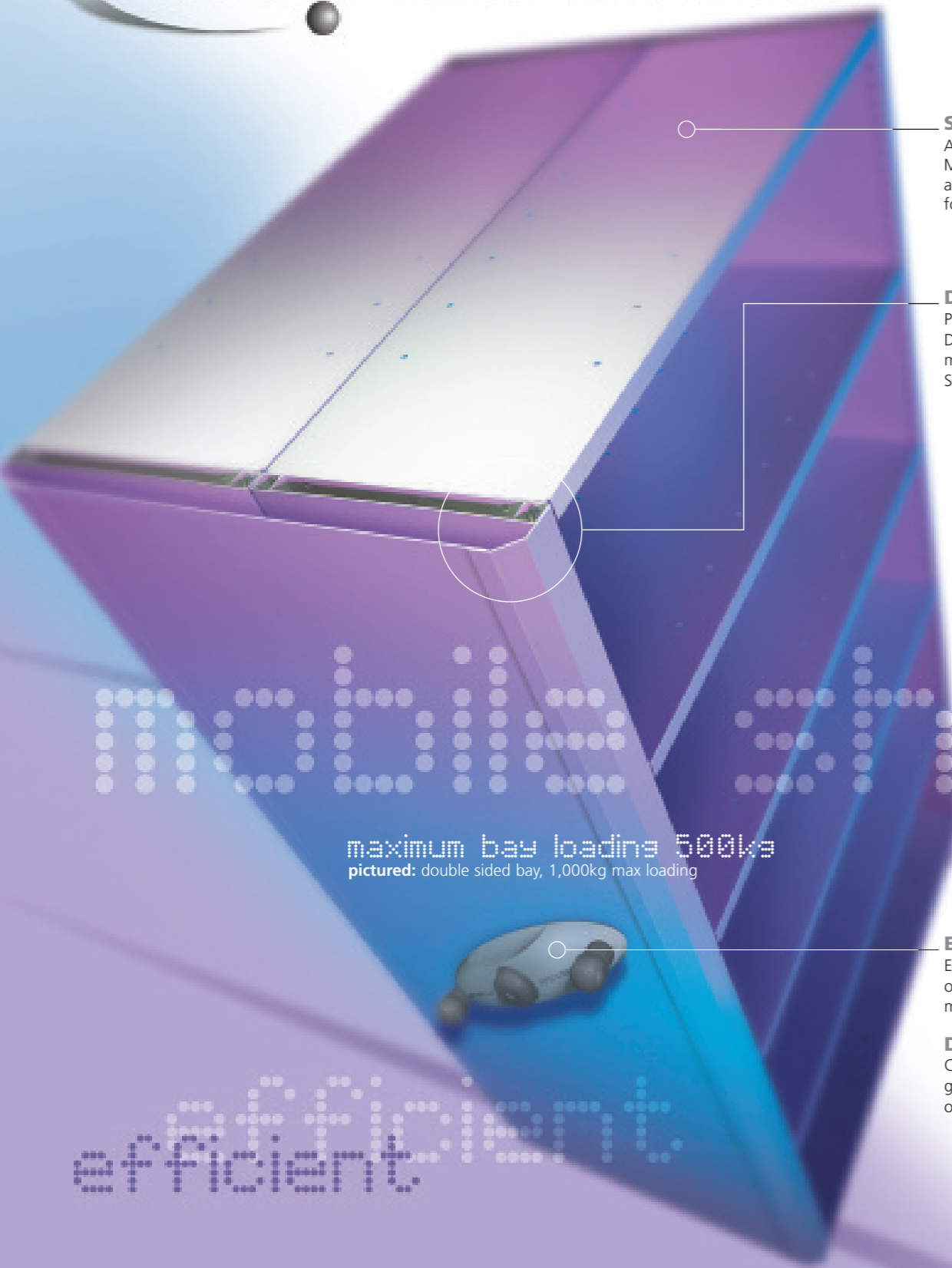

SHELVING AC+IVECOAT®
Available with Probe's Diablo, Mistral, Industrial Angle and Rolled Edge Shelving for added flexibility.

DECOR END PANELS
Probe offer these optional Decor End Panels in a range of materials, finishes and colours. See next page for details.

ERGONOMIC HANDLE
Ergonomic handle with optional built in locking mechanism for safe operation.

DRIVE MECHANISM
Chain driven with mechanical gear reduction, making operation simple and light.

maximum bay loading 500kg
pictured: double sided bay, 1,000kg max loading

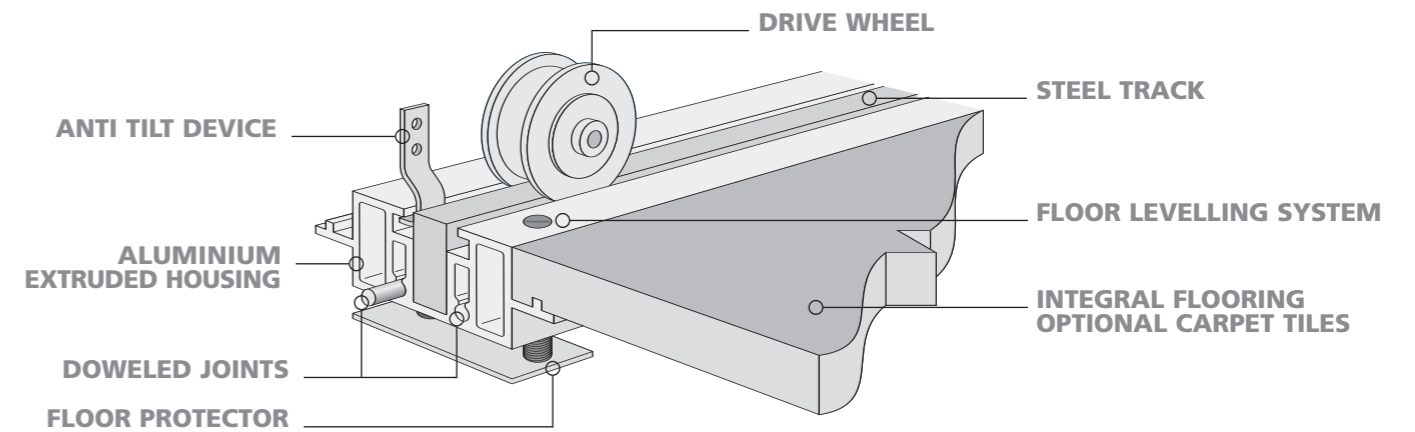

TRACK SPECIFICATIONS

Lengths	1200, 1800, 2400mm
Widths	99mm (65mm visible)
Height	38mm
Material	Aluminium extrusion 6063T6
Rolling surface:	12 x 30mm bright mild steel
Finish	Anodised natural AA10

FLOOR PANELS

Depth	600mm
Widths	750, 1000mm (nom)
Material	18mm Flooring grade chipboard
Finish	Laminate/Optional carpet tiles

DRIVE SPECIFICATIONS

1.866:1 mechanical reduction gearing.
Effort 0.8kg/100kg

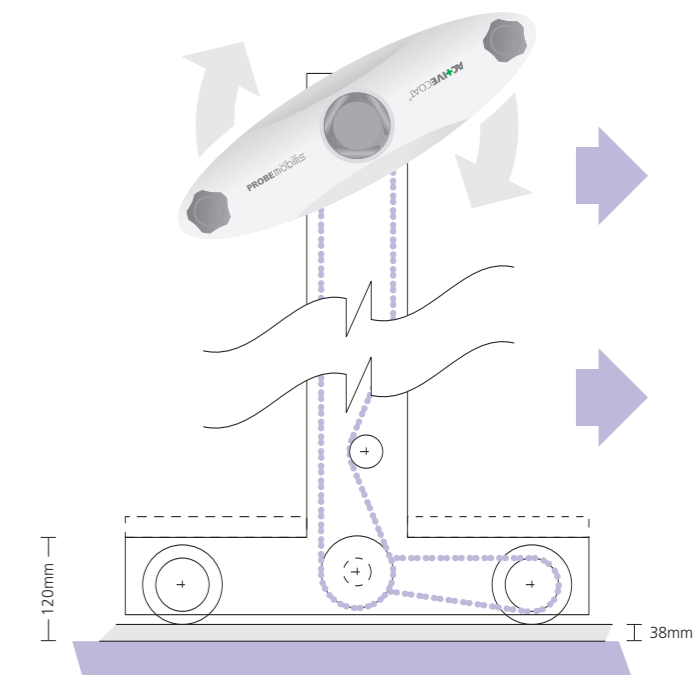

increase storage space

MÖBILIS MOBILE SHELVING
Below are two examples of shelving in the same area. Probes Mobile Shelving System increases shelving area by as much as **100%**.

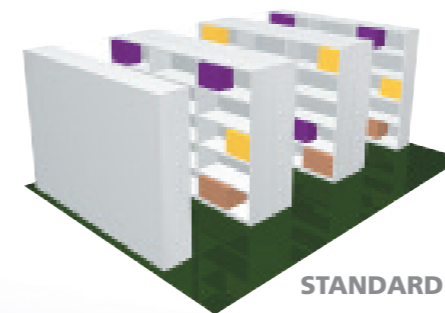

STANDARD SHELVING

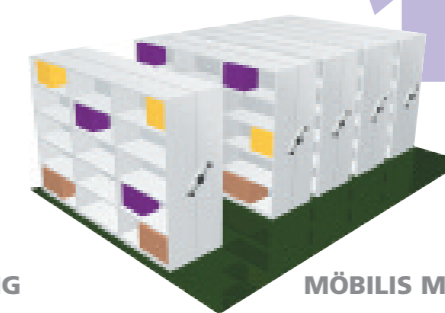

MÖBILIS MOBILE SHELVING

UP TO **100%**
SPACE
SAVING

MOBILE SHELVING

Möbilis MOBILE SHELVING

space saving

MÖBILIS

This Medium Duty Mobile Shelving System from Probe offers the highest quality track, mechanism and cradle. It will accommodate Probe's Mistral, Diablo, Industrial Angle and Rolled Edge shelving systems. Create up to 100% more storage space in your existing archive area.

MÖBILIS MOBILE SHELVING

A completely freestanding mobile shelving system, no drilling, no fixing down, no messy ground or civil works. It will not damage or disturb your carpet or floor covering in any way.

INTEGRAL FLOOR

The integral floor provides a secure, rigid and safe platform to walk on.

HEIGHT ADJUSTABLE TRACK

The unique screw adjustment from above ensures a level track even on uneven floors. Track joints are doweled and screwed for security and efficiency.

ANTI TILT

Ultra safe anti-tilt mechanism locks shelving into the track.

MÖBILIS MOBILE BASE

The standard base comes with drive mechanism housed in colour co-ordinated section. See below for optional Decor End Panels



SHELVING

Pictured with Probes stylish Mistral Shelving System.

DECOR END PANELS

Probe offer a large range of, optional, high quality decor end panels to suit your environment. Standard mobile system is supplied without decor end panels.

ACTIVECOAT[®] ERGONOMIC HANDLE

Ergonomic handle with built in locking mechanism for safe operation. Optional lock and key available for added security.

DRIVE MECHANISM

Chain driven with mechanical gear reduction, making operation simple and light.

END STOPS

LOW PROFILE BASE

Increases floor height by a mere 80mm. Additional 50mm to base of shelving.

HEIGHT ADJUSTABLE TRACKS

Height adjustable tracks enable installation on uneven floors and as the tracks are not fixed to the existing floor, the entire mobile system can be easily relocated.

INTEGRAL TEXTURED FLOOR

many colours available

Contact your local Probe distributor for details of colours and finishes to suit your environment.

FLOORING RAMP

Enabling installation on top of existing flooring.

A WIDE RANGE OF LAMINATE COLOURS ARE AVAILABLE

Optional Decor End Panels

This is a small sample of the finishes available. Others available on request. *Denotes timber effect.

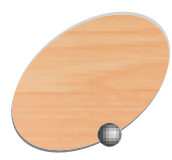

ASH*



BEECH*



OAK*



MAPLE*



SMOKE WHITE STEEL



PERFORATED STEEL

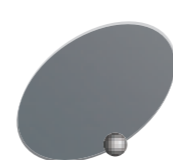

A WIDE RANGE OF LAMINATE COLOURS ARE AVAILABLE

Diablo DOUBLE SKIN



SMOKE WHITE AC+IVECOAT®
The new hard wearing, anti-bacterial powder coating exclusively from Probe, developed in conjunction with DUPONT.

SHELVES
A quick and simple system to build with shelves being clipped in place.

FLUSH DOUBLE SKIN
This unique, stylish shelving system offers maximum usable shelf width and unimpeded access.

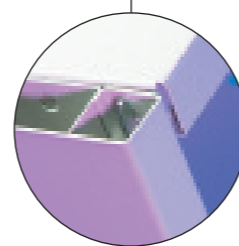

maximum bay loading 500kg
dependent on specification

pictured: single bay

BS:5454 COMPLIANT
Clean sidewalls with no exposed clips ensure valuable books and files stay in perfect condition making this system ideal for libraries, archives and offices.



FLUSH DOUBLE SKIN SIDEWALLS
This unique, stylish shelving system offers maximum usable shelf width and unimpeded access.

SHELF OPTIONS
A range of shelves are available to suit your needs, including pull out shelves and filing cradles & frames.

DIABLO DOUBLE SKIN
These stylish shelving bays carry a maximum bay loading of 500kg.

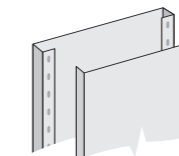
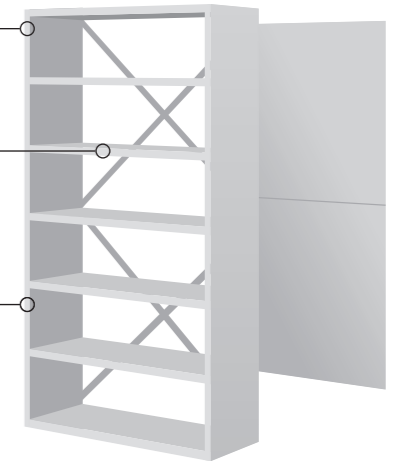

FLUSH DOUBLE SKIN SIDEWALLS
Ideal for libraries, archives and offices with clean sidewalls and no exposed clips ensuring safe usage for staff and customers alike.

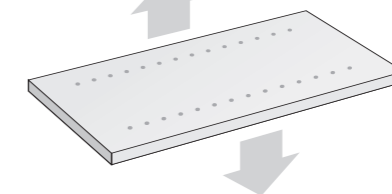

SHELF ADJUSTMENT
Shelves can be raised or lowered by 25mm increments making this system extremely versatile.

BAY DIMENSIONS

Height (mm) Sidewalls	Widths (mm) Shelf	Depths (mm)			
		250	300	350	400
1880	750
	900
	1000
2230	1200

Individual fixed shelf loadings 80kgs UDL

PULL OUT SHELVES

Height (mm) Sidewalls	Widths (mm) Shelf	Depths (mm)			
		250	300	350	400
1880	750
	900
	1000
2230	1000

Individual shelf loading of 40kgs UDL

PULL OUT FILE CRADLE

Height (mm) Sidewalls	Widths (mm) Cradle	Depths (mm)			
		250	300	350	400
1880	750
	900
	1000
2230	1000

Individual cradle loading of 40kgs UDL

LATERAL FILING FRAME

Height (mm) Sidewalls	Widths (mm) Frame	Depths (mm)			
		250	300	350	400
1880	750
	900
	1000
2230	1000

Individual filing frame loading of 40kgs UDL

bay bracing requirements
maximum bay loading 500kg
dependent on specification

BAYS AERIAL VIEW WITHOUT CLADDING

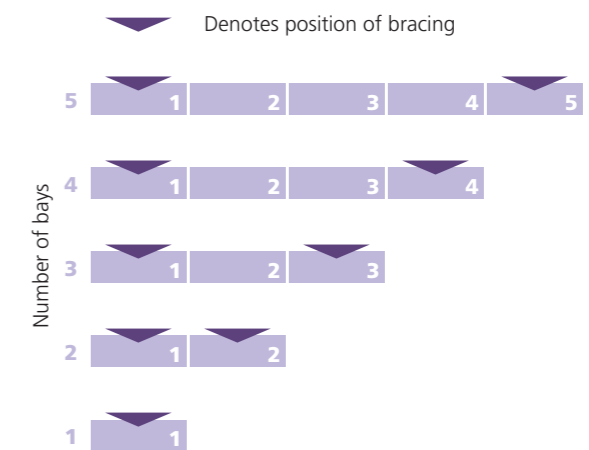

This system does not need bracing if fully clad.

DIABLO CONTINUED

Diablo DOUBLE SKIN

DIABLO DOUBLE SKIN

This unique and stylish shelving system offers maximum usable shelf width and unimpeded access, ideal for libraries, archives and offices. Clean sidewalls ensure valuable stored items are not damaged.

office



BS:5454 COMPLIANT

Clean sidewalls with no exposed clips ensure valuable books and files stay in perfect condition making this system ideal for libraries, archives and offices.

SHELF OPTIONS

A wide range of standard shelves are available to suit your needs.

SHELF ADJUSTMENT

Shelves can be raised or lowered by 25mm increments making this system extremely versatile.

FEATURES & BENEFITS

- Flush **Double Skin** for safe unimpeded access.
- Clean sidewalls allow full width access to shelves.
- Smoke white powder coated for a durable, clean and stylish look



library



Accessories

FEATURES & BENEFITS

- Quick and easy to build for minimum disruption when being installed.
- A large range of accessories to tailor this system to your specific needs.



STANDARD SHELF

To complement this system, a wide range of shelf options have been made available to suit your needs.



PULL OUT SHELF

These Pull Out Shelves offer quick and convenient access to many items. UDL 40Kg

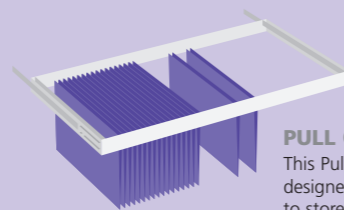

PULL OUT CRADLE

This Pull Out Cradle is designed to give easy access to stored hanging files and is available in two depths: 350mm & 400mm UDL 40Kg

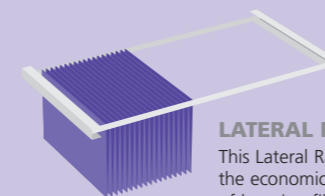

LATERAL RAIL

This Lateral Rail allows for the economical storage of hanging files and is available in two depths: 350mm & 400mm UDL 40Kg



DIVIDERS

A large range of Full height Dividers are available, see price guide for all options.



PART HEIGHT SHELF DIVIDER

These dividers are designed for easily creating individual part height compartments on shelves.

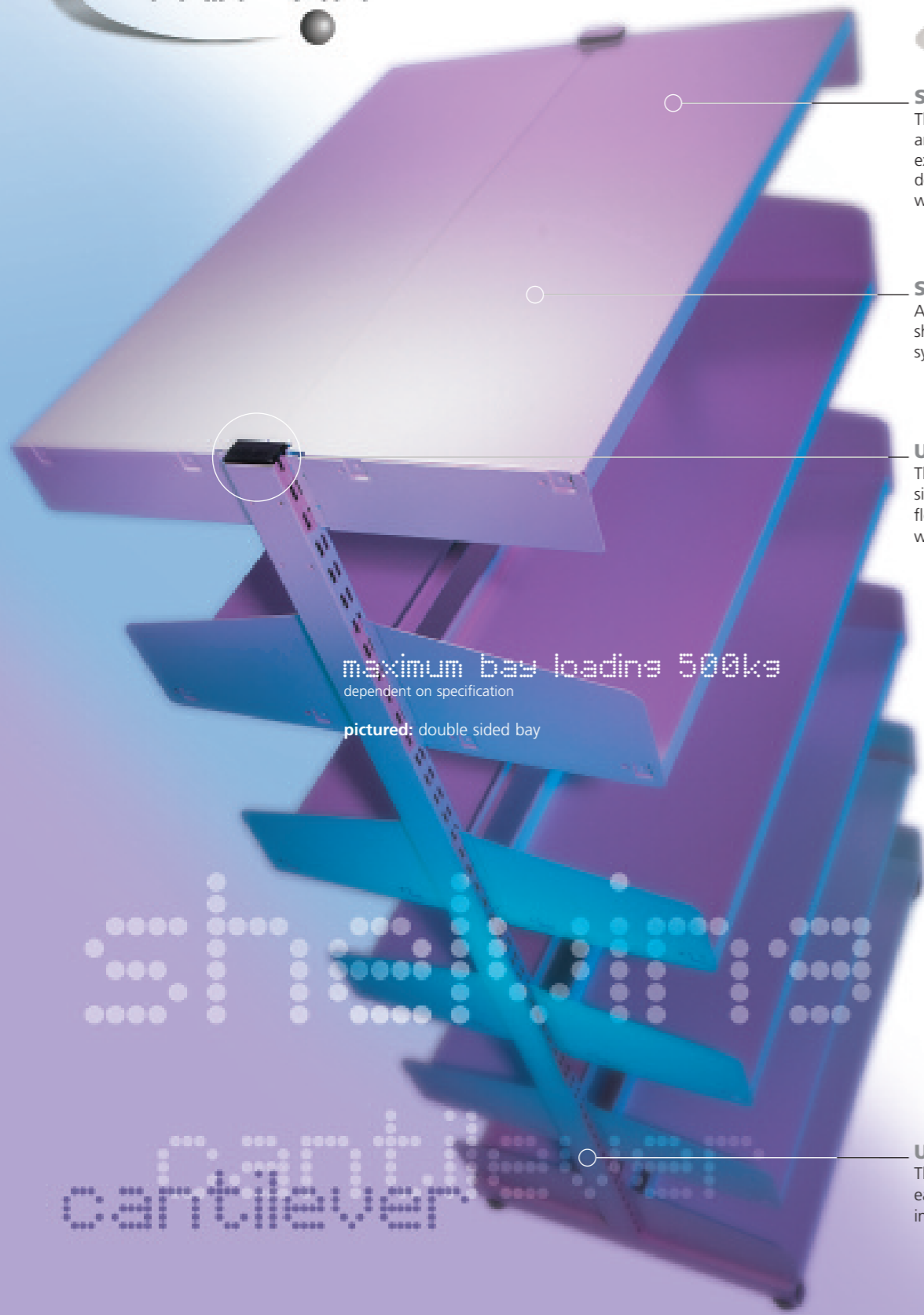

SMOKE WHITE ACTIVECOAT®

The new hard wearing, anti-bacterial powder coating exclusively from Probe, developed in conjunction with DUPONT.

SPECIAL USE SHELVES

A wide range of special use shelves are available to adapt this system to your individual needs.

UPRIGHTS

This versatile system includes single & double sided floorstanding uprights and wall mounted uprights.

maximum bay loading 500kg
dependent on specification

pictured: double sided bay

UPRIGHTS

These uprights allow for quick and easy adjustment of shelves in increments of 35mm.

versatile

SINGLE SIDED BAYS pictured right

Height (mm) Uprights	Widths (mm) Shelf
1200	750
1500	
1800	900
2100	
2300	

DOUBLE SIDED BAYS pictured left

Height (mm) Uprights	Widths (mm) Shelf
1200	750
1500	
1800	900
2100	
2300	

WALL MOUNTED BAYS pictured right

Height (mm) Uprights	Widths (mm) Shelf
1030	750
1380	
1680	900
2030	
2300	

maximum bay loading 500kg
dependent on specification

MAXIMUM SHELF LOADING (UNIFORMLY DISTRIBUTED)		
SHELF	SIZE(mm)	UDL
Flush/Canopy Shelf	750 x 250	65kg
	750 x 300	65kg
	900 x 250	65kg
	900 x 300	65kg
Display Shelf	750	65kg
	900	65kg
Tape Cassette or CD/DVD Shelf	900	65kg
Video Shelf	900	65kg
Display & Storage Shelf	900 x 350	65kg
Standard Shelf	750 x 250	65kg
	750 x 300	65kg
	900 x 250	65kg
	900 x 300	65kg

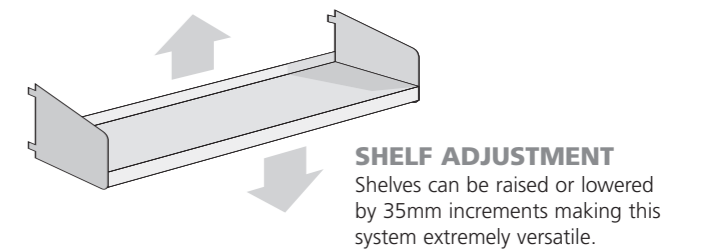
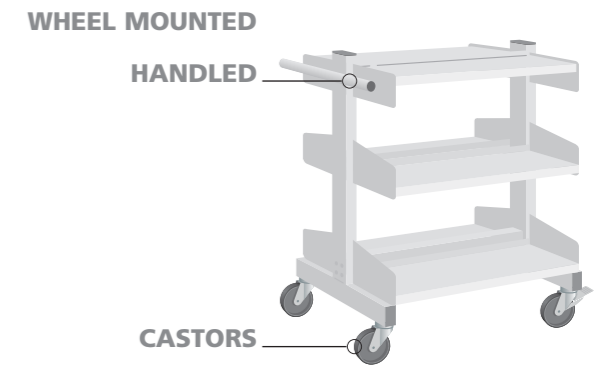
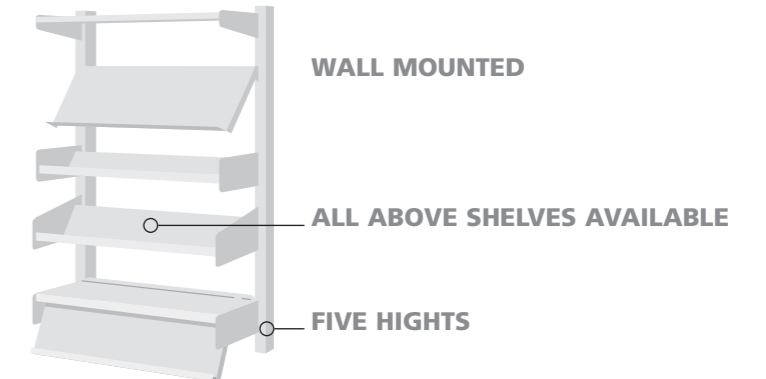
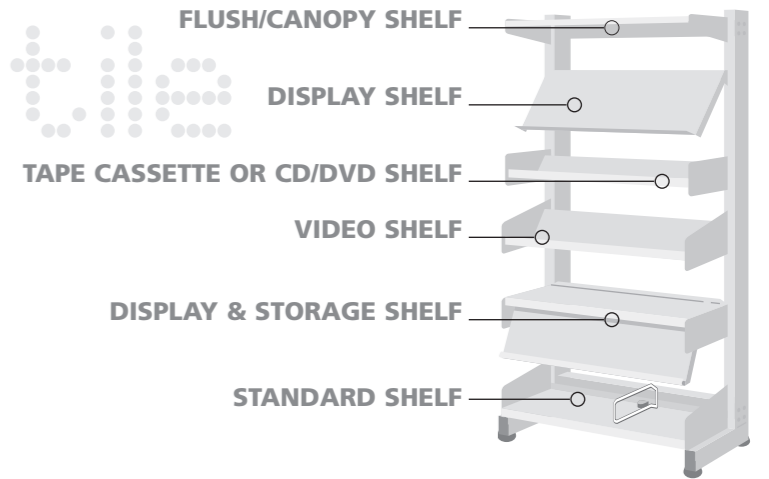

Nörvik Office Shelving

NÖRVIK SHELVING

This versatile shelving system offers a wide range of specialist shelves and accessories to suit your business. Nörvik Office can be quickly adapted to meet your changing needs.



● SINGLE SIDED BAYS

5 HEIGHT OPTIONS

Available in five heights 1200, 1500, 1800, 2100 & 2300mm and two depths 250 & 300mm. Note: Wall mounted available in different heights, see technical page.

SHELF OPTIONS

A wide range of shelf options has been made available to suit your needs.

A STYLISH SYSTEM

A stylish system well suited to your office environment.

QUICK BUILD

This versatile shelving system is quick and easy to construct, saving down time and minimising disturbance.

FEATURES & BENEFITS

- Elegant and sturdy construction
- A quick and easy to build system
- Compatible with System 4

of Office

● WALL MOUNTED BAYS



● DOUBLE SIDED BAYS



● WHEEL MOUNTED LOW BAY



FEATURES & BENEFITS

- Full range of optional accessories.
- Adjustable feet (except wall & wheel mounted units).

Accessories



STANDARD SHELF

A wide range of shelf options are available to suit your needs. Pictured with an optional Wire Divider ideal for supporting filing wallets.



DISPLAY SHELF

Display documents, brochures and products. UDL 65Kg



DISPLAY & STORAGE SHELF

This shelf is similar to the display shelf with the added facility to store a number of displayed items. UDL 65Kg



TAPE/VIDEO CASSETTE OR CD/DVD SHELF

UDL 65Kg



FLUSH/CANOPY SHELF

Used at the top of this system to maximise storage space. UDL 65Kg

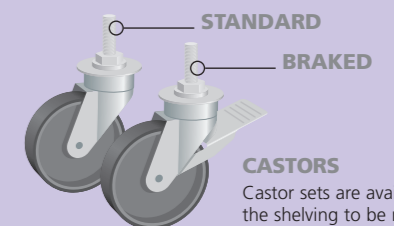

CASTORS

Castor sets are available enabling the shelving to be moved easily.

Nörvik Library Shelving

NÖRVIK LIBRARY SHELVING

This versatile shelving system offers a wide range of specialist shelves and accessories to suit your library. Nörvik Library can be quickly adapted to meet your changing needs.



● DOUBLE SIDED BAYS

5 HEIGHT OPTIONS

Available in five heights 1200, 1500, 1800, 2100 & 2300mm and two depths 250 & 300mm. Note: Wall mounted available in different heights, see technical page.

SHELF OPTIONS

A wide range of shelf options has been made available to suit your needs.

A STYLISH SYSTEM

A stylish system well suited to your office environment.

QUICK BUILD

This versatile shelving system is quick and easy to construct, saving down time and minimising disturbance.

FEATURES & BENEFITS

- Elegant and sturdy construction
- A quick and easy to build system
- Compatible with System 4



● WHEEL MOUNTED LOW BAY

library shelving



● SINGLE SIDED BAYS

FEATURES & BENEFITS

- Full range of optional accessories.
- Adjustable feet (except wall & wheel mounted units).

Accessories



STANDARD SHELF

A wide range of shelf options are available to suit your needs. Pictured with an optional Wire Divider ideal for supporting filing wallets.



DISPLAY SHELF

Display documents, brochures and products. UDL 65Kg



DISPLAY & STORAGE SHELF

This shelf is similar to the display shelf with the added facility to store a number of displayed items. UDL 65Kg



TAPE/VIDEO CASSETTE OR CD/DVD SHELF

UDL 65Kg



FLUSH/CANOPY SHELF

Used at the top of this system to maximise storage space. UDL 65Kg

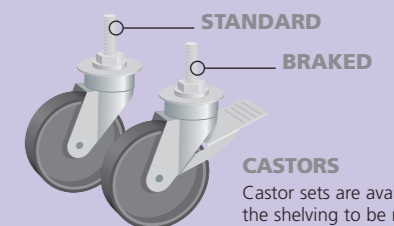

CASTORS

Castor sets are available enabling the shelving to be moved easily.

Mistral TRUE DELTA



SMOKE WHITE ACTIVECOAT[®]
The new hard wearing, anti-bacterial powder coating exclusively from Probe, developed in conjunction with DUPONT.

SHELVES
A quick and simple system to build with shelves being clipped in place.

TRUE DELTA EDGE
This, slim, True Delta Edge adds style and strength to this high quality shelving system.

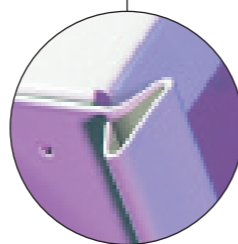

maximum bay loading 500kg
dependent on specification

pictured: single bay

A STYLISH SOLUTION
Available in three heights, six depths and with a range of special use shelves and accessories, you are sure to find what you are looking for.

3 HEIGHT OPTIONS
Uprights available in 3 heights and six depths.

SHELF OPTIONS
A range of shelves are available to suit your needs, including pull out shelves and filing cradles & frames.

DECOR END PANELS
Add the finishing touch to this stylish system with these neat decor end panels.

DOOR & FRAME SETS
These convenient door sets allow an added security feature to this universal system. Available in 1880mm & 2230mm high and 1000mm wide.

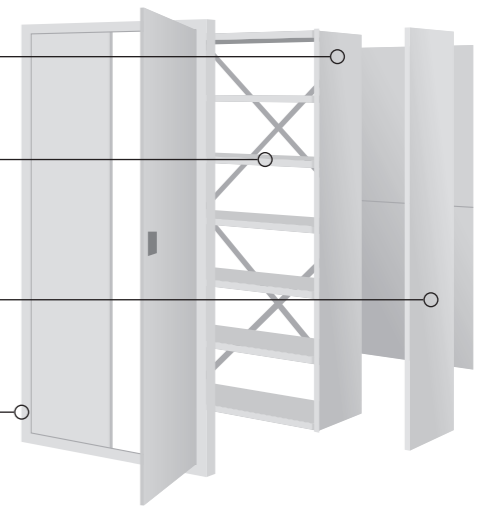

BAY DIMENSIONS

Height (mm)	Widths (mm)			Depths (mm)				
	Sidewalls	Shelf	250	300	350	400	450	600
1880	}	750
2230		900
2580		1000

Individual shelf loading of 80kgs UDL.

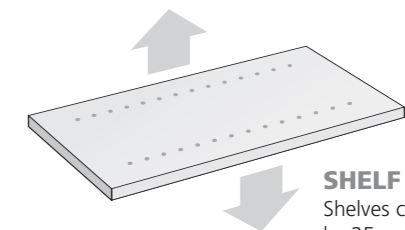

SHELF ADJUSTMENT
Shelves can be raised or lowered by 25mm increments making this system extremely versatile.

bay bracing requirements

maximum bay loading 500kg
dependent on specification

BAYS AERIAL VIEW

WITHOUT CLADDING

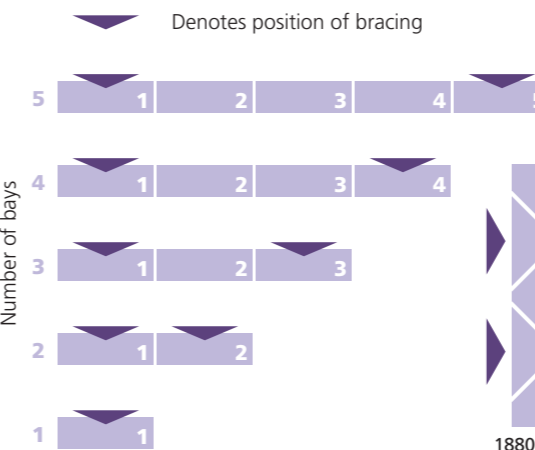

BAY REAR VIEW



This system does not need bracing if fully clad.

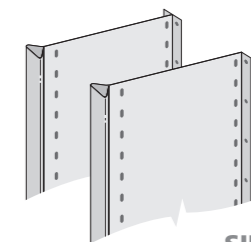

SIDEWALLS
Mistral sidewalls blend strength with appearance through innovative design and manufacture. Intermediate and end sidewalls available.

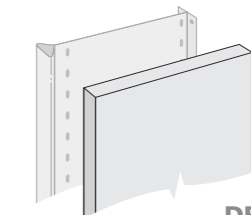

DECOR END PANELS
Mistral offers an optional Decor End Panel to add that finishing touch to this attractive system.

Mistral TRUE DELTA

MISTRAL

This is a stylish shelving system which offers a wide range of accessories making it a flexible and affordable option for all your storage needs.



3 HEIGHT OPTIONS

A range of heights and depths are available to suit your needs.

SHELF OPTIONS

A wide range of shelf sizes and special use shelves have been made available to suit your needs.

DOOR SET

These convenient door sets allow secure storage of valuable items within this affordable system.

TRUE DELTA

These True Delta uprights give this system a stylish appearance while adding strength.

FEATURES & BENEFITS

- A stylish and affordable shelving system.
- **ACTIVECOAT**[®] Probe's new hard wearing, anti-bacterial, powder coating make this system suitable for clean environments.
- Shelves may be clipped for quick and easy assembly or bolted for added strength.



commercial



Accessories

FEATURES & BENEFITS

- Quality engineered to provide a sturdy and robust shelving system that will give many years of service.
- A wide range of accessories makes this a truly flexible system to suit your needs.



COMMERCIAL SHELF

To complement this system, a wide range of shelf options have been made available to suit your needs.



PULL OUT SHELF

These Pull Out Shelves offer quick and convenient access to many items.
UDL 40Kg

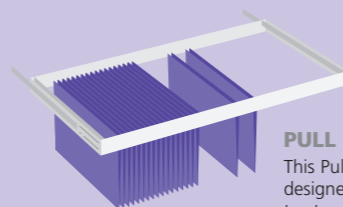

PULL OUT CRADLE

This Pull Out Cradle is designed to give easy access to stored hanging files and is available in two depths: 350mm & 400mm
UDL 40Kg

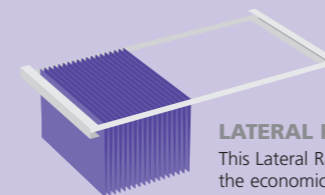

LATERAL RAIL

This Lateral Rail allows for the economical storage of hanging files and is available in two depths: 350mm & 400mm
UDL 40Kg

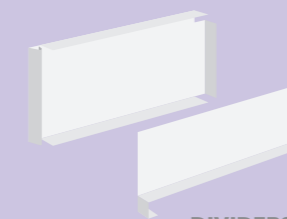

DIVIDERS

A large range of Full and Part height Dividers are available, see price guide for all options.



DOOR SETS

These convenient door sets allow an added security feature to this universal system. Available in 1880mm & 2230mm high and 1M wide.

Industrial Angle

Strength



DOVE GREY AC+IVECOAT®
The new hard wearing, anti-bacterial powder coating exclusively from Probe, developed in conjunction with DUPONT.

maximum bay loading 6800kg
dependent on specification

pictured: single bay

ROLLED ANGLE POST
This universal system offers maximum strength for heavy industrial applications.

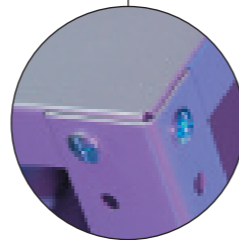

HEAVY DUTY SHELVES
Both Commercial and British Standard shelves are available in many widths and depths for maximum flexibility.

BS:826 MANUFACTURED
Manufactured in accordance with BS:826:1955

HEIGHT OPTIONS
Available in a wide range of heights and depths.

SHELF OPTIONS
A wide range of shelf sizes have been made available to suit your needs.

DOOR & FRAME SETS
These convenient door sets offer an added security feature to this universal system. Available in 75" & 87" high and 36" wide.

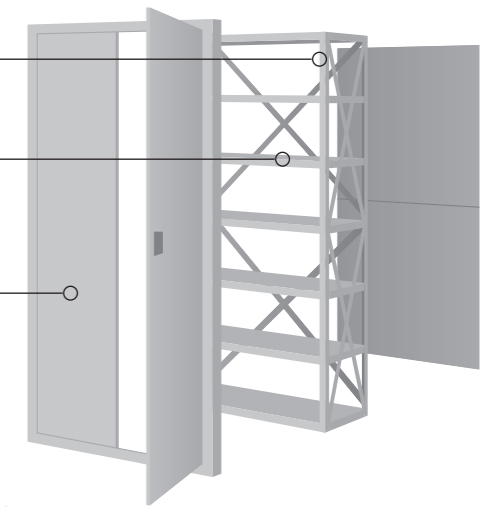

SHELF ADJUSTMENT
Shelves can be raised or lowered by 1" (25.4mm) increments making this system extremely versatile.

SHELF CLIPS
Shelves may be seated on clips for ease of adjustment but maximum shelf loading is reduced. Specific shelves still need to be bolted, refer to technical department for specification.

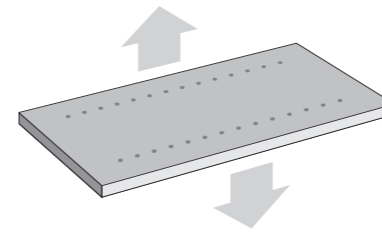

BAY DIMENSIONS

Height (inch)	Widths (inch)	Depths (inch)					
		12	15	18	24	30	36
39	24
51	30
63	36
75	42
87	48
99	1M
111	
123	

Individual shelf loadings from 115-204kgs UDL

bay bracing requirements
maximum bay loading 6800kg
dependent on specification

BAYS REAR VIEW WITHOUT REAR CLADDING

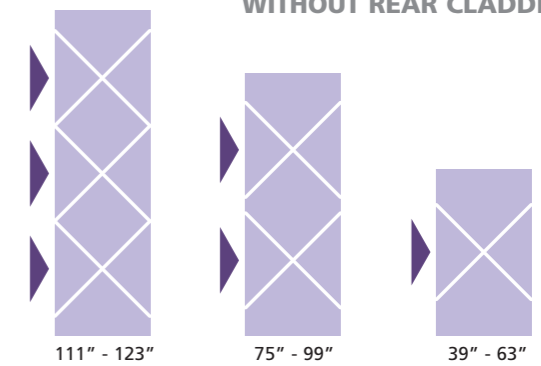

BAYS AERIAL VIEW WITHOUT CLADDING

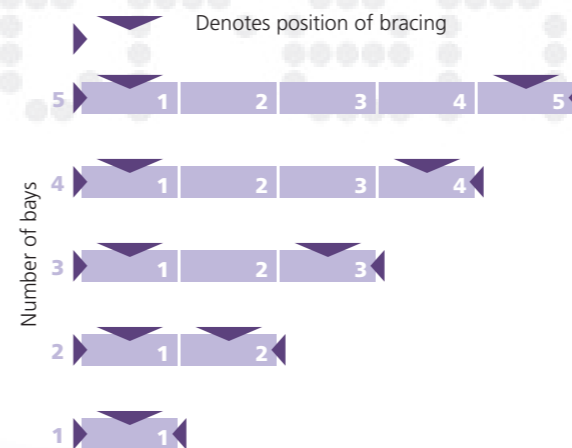

BAYS AERIAL VIEW WITH BACK CLADDING ONLY

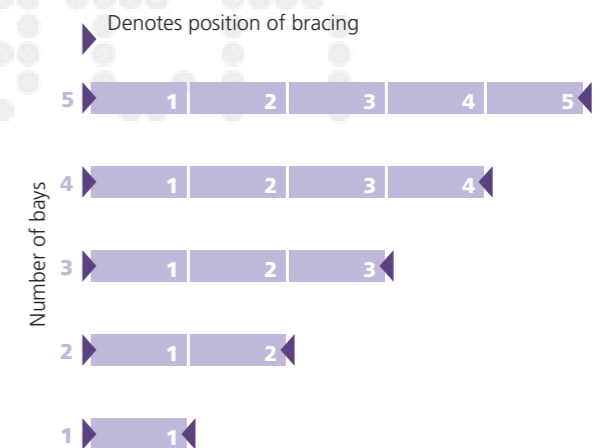

This system does not need bracing if fully clad.

compatible

Industrial Angle

INDUSTRIAL ANGLE

This shelving system offers maximum strength and flexibility. It also offers our widest range of sizes to accommodate your space and is fully compatible with any similar, third party, BSS systems you may already have.



HEIGHTS TO SUIT

Available in many standard heights and may be supplied cut to your own specification. These uprights come in two strengths, Heavy Duty and Ultra-Heavy Duty.

HEAVY DUTY SHELVES

Both Commercial and British Standard shelves are available in many widths and depths for maximum flexibility.

DOOR SET

These convenient door sets allow secure storage of valuable items within this universal system.

FEATURES & BENEFITS

- Extremely strong construction.
- Fully compatible with all similar, third party, BSS systems.
- **ACTIVECOAT**[®] Probe's new hard wearing, anti-bacterial, powder coating greatly improves levels of hygiene in your environment.



universal



Accessories

FEATURES & BENEFITS

- Quality engineered to provide a shelving system that will give many years of service.
- A large range of optional accessories to accommodate your specific needs.

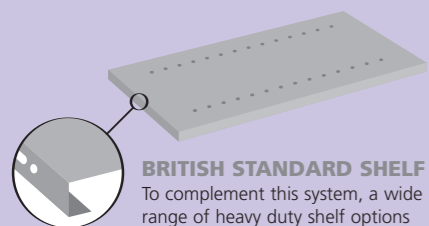

BRITISH STANDARD SHELF
To complement this system, a wide range of heavy duty shelf options has been made available to suit your needs.

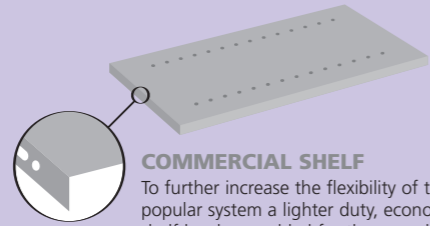

COMMERCIAL SHELF
To further increase the flexibility of this popular system a lighter duty, economical, shelf has been added for those applications where ultimate strength is not required.

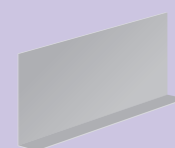

PART HEIGHT SHELF DIVIDER
These dividers are designed for easily creating individual part height compartments on shelves.

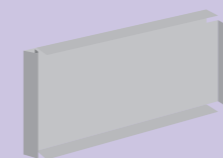

SHELF DIVIDER
These dividers are perfect for creating individual compartments on shelves and are available in a range of depths and heights.

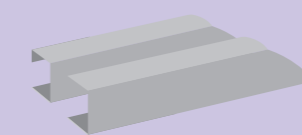

RETAINING BIN FRONT AND PLINTH
Retaining Bin Fronts are easily fixed to shelves preventing items rolling off. Plinths fit to bottom of bay preventing items rolling under.



DOOR SETS
These convenient door sets allow an added security feature to this universal system. Available in 75" & 87" high and 36" wide.

Rolled Edge



DOVE GREY AC+IVECOAT®
The new hard wearing, anti-bacterial powder coating exclusively from Probe, developed in conjunction with **DUPONT**.

SHELVES
Both Commercial and British Standard shelves are available in many widths and depths for maximum flexibility.

SLIM VERTICAL EDGE
This, slim, rolled edge allows maximum shelf width to be used while adding strength to this system.

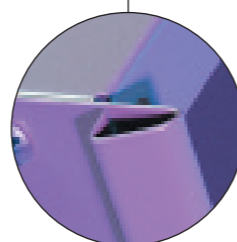

maximum bay loading 500ks
dependent on specification

pictured: single bay

ROLLED EDGE UPRIGHTS
Available in three heights 75", 87" & 99" and four depths 12", 15", 18" & 24".
Note: 99" not available in 24" depth.

3 HEIGHT OPTIONS
75" 87" and 99" uprights in a choice of depths.

4 SHELF DEPTHS & 6 WIDTHS
A wide range of shelf options have been made available to suit your needs. Not all depths are available with all widths, see price guide for a comprehensive list.

SPECIAL USE SHELVES
See the next page for the full range of pull out and filing shelves.

DOOR & FRAME SETS
These convenient door sets allow an added security feature to this universal system. Available in 75" & 87" high and 36" wide.

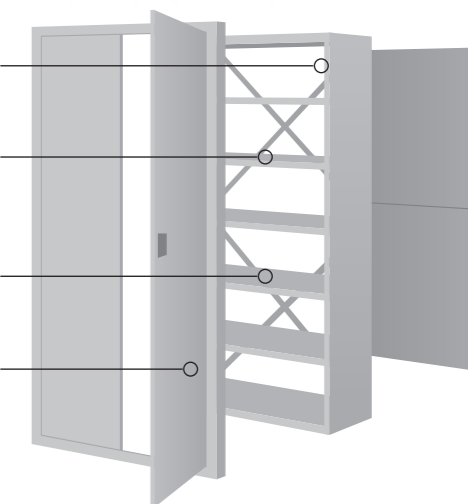

BAY DIMENSIONS

Height (inch)	Widths (inch)	Depths (inch)			
		12	15	18	24
75	24"	•	•	•	•
	30"	•	•	•	•
	36"	•	•	•	•
	48"	•	•	•	•
87	1M	•	•	•	•
	42"	•	•	•	•
99	42"	•	•	•	•
	48"	•	•	•	•

Individual fixed shelf loadings 90-205kgs UDL
See price list for individual shelf loadings.

PULL OUT SHELVES

Height (mm)	Widths (mm)	Depths (mm)	
		15"	18"
75	36"	•	•
		•	•
		•	•
87	36"	•	•
99	36"	•	•

Individual shelf loading of 40kgs UDL.

PULL OUT FILE CRADLE

Height (mm)	Widths (mm)	Depths (mm)	
		15"	18"
75	36"	•	•
		•	•
		•	•
87	36"	•	•
99	36"	•	•

Individual cradle loading of 40kgs UDL.

LATERAL FILING FRAME

Height (mm)	Widths (mm)	Depths (mm)	
		15"	18"
75	36"	•	•
		•	•
		•	•
87	36"	•	•
99	36"	•	•

Individual filing frame loading of 40kgs UDL.

SLIM VERTICAL EDGE

Slim Vertical Edge rolled for added strength and style. Pictured with optional Decor End Panels to finish off bay ends neatly.

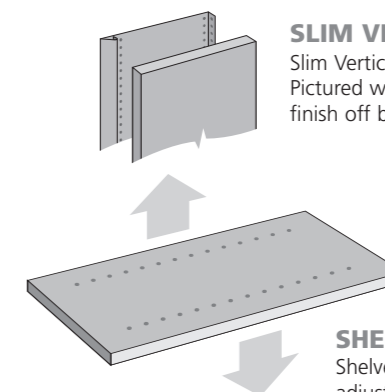

SHELF ADJUSTMENT

Shelves can be raised or lowered by 1" (25.4mm) increments making this system extremely versatile.

SHELF CLIPS

Shelves may be seated on clips for ease of adjustment but maximum shelf loading is reduced. Specific shelves still need to be bolted, refer to technical department for specification.

bay bracing requirements
maximum bay loading 500ks
dependent on specification

BAYS AERIAL VIEW

WITHOUT CLADDING

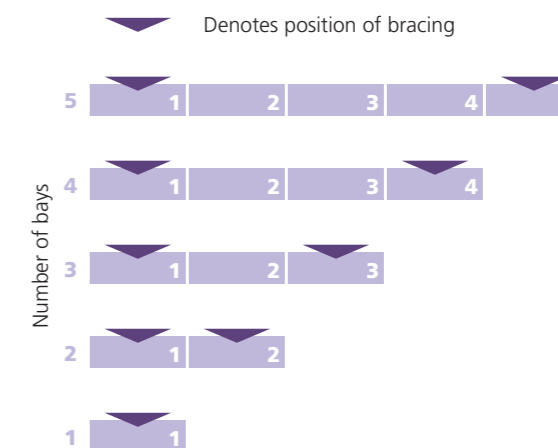

BAY REAR VIEW



This system does not need bracing if fully clad.

Rolled Edge Edge

ROLLED EDGE

This neat shelving system with its Slim Vertical Edge gives increased access to shelves and is fully compatible with all, third party, rolled edge shelving systems.



3 HEIGHT OPTIONS

Available in three heights 75", 87" & 99" and four depths 12", 15", 18" & 24". Note: 99" not available in 24" depth.

4 SHELF DEPTHS AND 6 WIDTHS

A wide range of shelf options have been made available to suit your needs. Not all depths are available with all widths, see price guide for a comprehensive list.

DOOR SET

These convenient door sets allow secure storage of valuable items within this universal system.

SLIM VERTICAL EDGE

This, slim, rolled edge allows increased access to shelves and gives added strength to this neat system.

FEATURES & BENEFITS

- Slim Vertical Edge giving increased access to shelves.
- Fully compatible with all, third party, rolled edge shelving systems.
- Shelves may be clipped for quick and easy assembly or bolted for added strength.



FEATURES & BENEFITS

- Quality engineered to provide a sturdy and robust shelving system that will give many years of service.
- **ACTIVECOAT**[®] Probe's new hard wearing, anti-bacterial, powder coating greatly improves levels of hygiene in your environment.

Accessories

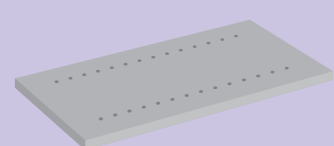

SHELVES

To complement this system, a wide range of shelf options have been made available to suit your needs.



PULL OUT SHELF

These Pull Out Shelves offer quick and convenient access to many items. UDL 40Kg

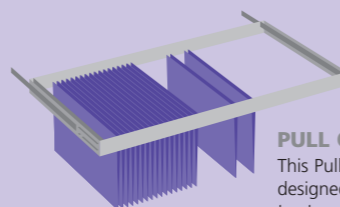

PULL OUT CRADLE

This Pull Out Cradle is designed to give easy access to stored hanging files and is available in two depths: 15" & 18" UDL 40Kg

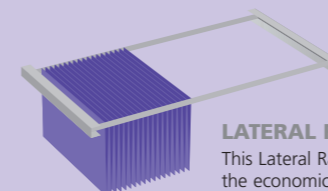

LATERAL RAIL

This Lateral Rail allows for the economical storage of hanging files and is available in two depths: 15" & 18" UDL 40Kg

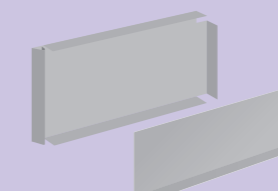

DIVIDERS

A large range of Full and Part height Dividers are available, see price guide for all options.



DOOR SETS

These convenient door sets allow an added security feature to this universal system. Available in 75" & 87" high and 36" wide.



THE **hard wearing**
anti-bacterial powder coating
for the most stringent hygienic environment.

ACTIVECOAT is a new, hard wearing, patent-protected powder coating containing elemental Silver ionically bonded into a bio-compatible ceramic material known as a Zeolite. This impedes the growth and migration of potentially harmful bacteria, mold, fungi, algae and more reducing the risk of cross-contamination from surface to surface. Especially suitable where stringent hygiene standards are required, such as health care, educational, catering and retail changing rooms.

- ✓ **99.9% REDUCTION OF E-COLI & MRSA SUPER BUG**
- ✓ **INDEPENDENTLY TESTED**
- ✓ **100% SAFE TO HUMANS**
- ✓ **EFFECTIVE FOR THE LIFE OF THE COATING**
- ✓ **ACTIVECOAT IS AVAILABLE IN ALL PROBE COLOURS**

MICROBIOLOGICAL TESTING

ACTIVECOAT has been tested by an Internationally recognised microbiological testing laboratory for antibacterial performance, against the most widely encountered and problematic organisms including the **MRSA Super bug** and **E-coli**. These micro-organisms suffered a **99.9%** reduction in population.

ACTIVECOAT is effective against harmful bacteria including:

- ✗ **ASPERGILLUS NIGER**
- ✗ **STAPHYLOCOCCUS AUREUS (MRSA Super Bug)**
- ✗ **PSEUDOMONAS AERUGINOSA**
- ✗ **STREPTOCOCCUS**
- ✗ **ESCHERICHIA COLI (E-coli)**

THE EFFECTIVE LIFE OF ACTIVECOAT

Unlike anti-bacterial sprays and chemical disinfectant which rely on repeated use **ACTIVECOAT** contains anti-bacterial agents uniformly distributed throughout the coating therefore antimicrobial efficacy will continue for the life of the coating.

PROBE PRODUCTS

All Probe products come as standard with **ACTIVECOAT** anti-bacterial powder coating. In addition, all plastic components used in the manufacture of Probe products incorporate a silver based anti-bacterial agent.

PROBE ACTIVECOAT DEVELOPED IN CONJUNCTION WITH DUPONT



The miracles of science™

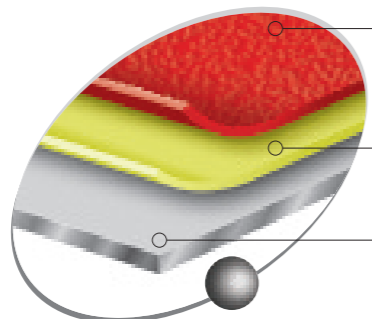

ACTIVECOAT®

The hard wearing anti-bacterial powder coating for the most stringent hygienic environment.

IRON PHOSPHATE KEY COAT

This anti-rust, key coat bonds to the steel in readiness for the final active coating.

PREPARED STEEL SURFACE

Chemical cleaning ensures an ideal surface for further coatings.



99.9% REDUCTION OF MRSA, E-COLI & BACTERIA
Antimicrobial efficiency will continue for the life of the coating.