



YEOMAN  
**SHIELD**

WALL & DOOR PROTECTION

OVER 40 YEARS OF SUCCESS



# YEOMAN SHIELD - THE MARKET LEADER IN WALL & DOOR PROTECTION



The success of an organisation is often measured on profitability and, in the case of a listed company, an impressive share price. Allow me to invite you to consider another benchmark, **People**, but more specifically, a company's employees, customers and suppliers.

Obviously you need a commodity that carries out a function and on viewing this brochure you will see that we have that in abundance with Yeoman Shield. We display a range of desirable, excellent products and most are available from stock. We continue to invent, design and improve. We also offer a full supply and fix service using our own directly employed operatives. But what we would like is for you to experience our unrivalled service.

It starts with our people and their morale. Job satisfaction is essential because a happy team desires to offer a service that is second to none. At the time of going to print we have a team of sixty-five people. Ten have gold watches that have been presented to them for giving us twenty-five years of their working life. Seven more "Golds" have retired and three more presentations will be made within the next five years. We have experience and expertise served up with a courtesy that sets us apart from our competitors.

People are also our customers and clients. People who put their faith in us to deliver to their expectations and we believe that they deserve the best. If you are an existing customer, thank you, your continued loyalty enables us to get to know you and deliver exactly what you require. If you are new to us then we look forward to treating you to a service that some only link to the traditions of yesteryear.

Our suppliers also have their part to play. They know that our business is customer focused and that without their support delays can occur. That is why we build up a relationship with them. They understand that they are an extension of our company and that, although they are invisible to our clientele, they have a responsibility that reaches beyond supplying us.

Since our foundation in 1966 we have learnt many lessons. It cannot reasonably be expected that people will go about their daily duties in such a careful manner so as not to cause any damage to the fabric of buildings. After all, we put them in charge of apparatus that positively helps.

Therefore, our attention is drawn toward preventative maintenance, not time consuming, costly repair. Visible fabric damage can harm your image.

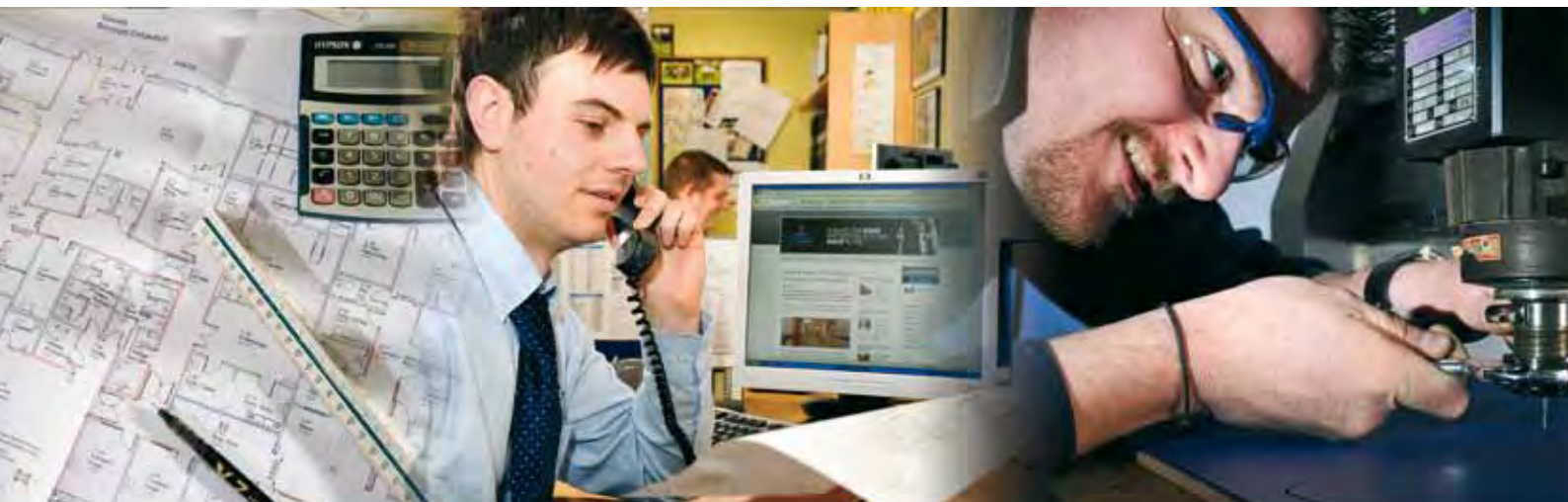



Yeoman Shield prevents damage. Once fitted it will be a front line defence in savings on repair and redecoration and is an investment that lasts for many years.

Our systems can blend into the background or be used to enhance the décor you desire. In this brochure you will see examples of both.

If you need any advice please get in touch. You control every next step. We can be involved when you are ready, new build or refurbishment. Our assistance is given freely be it over the phone or during a visit.

**Our motto of “Making Business a Pleasure” is inherent throughout.**

**Ray Saperia**  
Managing Director





# CONTENTS



## PROTECTION RAILS

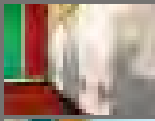

NEW PRODUCT DEVELOPMENT

6-7

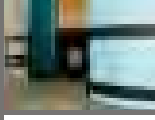

MARKET DIVERSITY

58-59



COLOURS & FINISHES

60-61



GENERAL INFORMATION

62-63

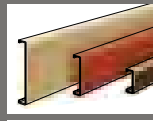

200, 125 & 75 PROTECTION RAIL

8-9

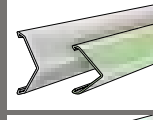

ULTRA 60 & 40 RAIL

10-11

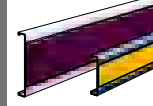

200 & 125 CONTRA RAIL

12-13

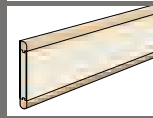

PREMIER PROTECTION RAIL

14-15

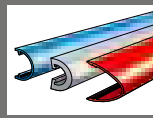

RIGI, FLEXI & MAXI RAIL

16-17

## HANDRAILS

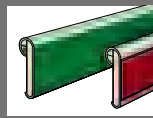

GUARDIAN HANDRAIL

18-19

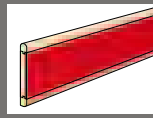

PREMIER HANDRAIL

20-21

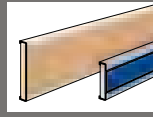







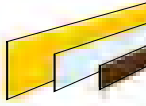

COMBINED HANDRAIL/  
PROTECTION RAIL



22-23



## WALL PROTECTION

|   |                                  |       |
|---|----------------------------------|-------|
|    | PROTECTION STRIP                 | 24-25 |
|    | WALL PROTECTION PANELS           | 26-27 |
|   | IMAGERY                          | 28-29 |
|  | CORNER PROTECTION ANGLES & TRIMS | 30-31 |
|  | ULTRA CORNER PROTECTION ANGLES   | 32-33 |
|  | BED HEAD PROTECTORS              | 34-35 |
|  | SKIRTING                         | 36-37 |
|  | FLOOR MOUNTED BOLLARDS           | 38-39 |

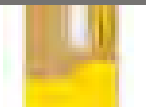
## DOOR PROTECTION

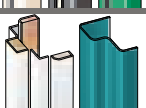
|   |                                    |       |
|---|------------------------------------|-------|
|  | DOOR PROTECTION PANELS & PLATES    | 40-41 |
|  | DOOR CLAPPING LATH                 | 42-43 |
|  | DOOR EDGE PROTECTORS               | 44-45 |
|  | DOOR FRAME & ARCHITRAVE PROTECTORS | 46-47 |

## HEAVY DUTY PROTECTION

|   |                                 |       |
|---|---------------------------------|-------|
|    | D-FENDER & C-FENDER             | 48-49 |
|    | E-FENDER & MINI E-FENDER        | 50-51 |
|   | DUO-FENDER & MINI DUO-FENDER    | 52-53 |
|  | MIDI-FENDER                     | 54-55 |
|  | HD100, HD100(H) & MD75, MD75(H) | 56-57 |





# NEW PRODUCT DEVELOPMENT



We recognise the importance of bringing new products to market to maintain a competitive edge and provide our customers with a greater choice of well designed, functional and reliable wall and door protection.

Our investment in new technology coupled with the ability to manufacture high quality products in house has enabled us to continually grow our range of aesthetically pleasing and performance driven systems such as **imagery** by Yeoman Shield (see page 28).

**imagery** brings a whole new dimension to wall and door protection panels uniting functional impact protection with aesthetically pleasing designs. Panels can be cut and shaped to create unique patterns and positive design concepts to influence the ambiance and atmosphere of public buildings.



airport or leisure centre, why not take advantage of our creative wall and door protection materials.

We are building up a choice of standard **imagery** designs ranging from relaxing and serene to eye-catching and bold. However, if you're feeling creative, you may prefer to specify your own unique concept to complement your interior. Please contact our Sales Office for further information and to obtain a quote.

In healthcare environments, attractive surroundings can have a positive therapeutic effect and the use of mood enhancing patterns and colours can contribute to calming, healing surroundings, which help aid treatment and recovery.

Bold shapes and bright colours introduce elements of fun and enjoyment into the décor of children's wards and schools by creating an uplifting and cheerful atmosphere.

The influence of décor and environment upon human behaviour is being increasingly recognised. So, if you are responsible for the maintenance of a public building such as a school, office, retail outlet,





We can cut panels in our workshop to replicate Logos, mottos and Coats of Arms. Important messages can also be inlaid into panels and certain Yeoman Shield rails (see pages 12, 14, 18, 20 & 22) to create effective signage. Rail signage is more user friendly for wheelchair users.



We listen to the needs of our customers and, in turn, endeavour to respond to demand and feedback by developing new and innovative systems such as the Yeoman Shield Door Clapping Lath (see page 42), which conceals the gap where X-Ray and laser room double doors meet. The door cover prevents the leakage of harmful radiation or laser beams and is also beneficial where privacy is required.



Continually updating and improving existing products is also important to us and we are quick to react to improvements and revisions that can be made to ensure we are in tune with changing customer tastes, economic conditions and technological advances.

One such product range that we have enhanced is the HD100 and MD75 rubber corner protection guards which have always been popular for use in loading bays. This effective system protects corners and columns minimising damage to both the impacting vehicle and the structure it is fitted to. Continued investment in new ideas has resulted in the development of a high visibility option. The visually attractive HD100 (H) and MD75 (H) incorporate brightly coloured textured inserts to denote a hazard (see page 56). The coloured alternative provides more interest for designers and specifiers enabling it to be used in other areas such as car parks.



We have widened the choice of both Skirting and Architrave & Frame Protection systems by adding a new product to each range. The split frame door protector (see page 46) is manufactured to a standard size providing a cost effective alternative to the successful bespoke post formed protector, which is a continuous profile manufactured to customer specifications. The new addition to the Skirting range (see page 36) is manufactured at 110mm. It is a hard wearing and cost effective alternative to timber skirting which is susceptible to damage.



# 200, 125 & 75 PROTECTION RAIL

Yeoman Shield Protection Rail comprises a rail and a range of compatible accessories, designed to protect areas likely to suffer damage caused by the movement of people and their activity. Correctly fitted, they will give many years of service.

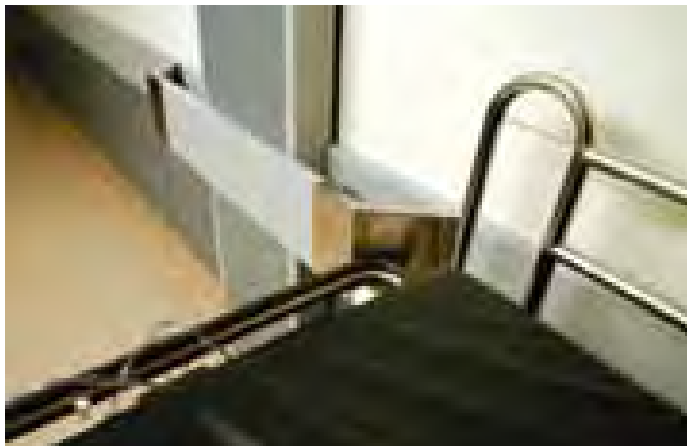

## Composition

The extruded rail and accessories are manufactured using Vinylac\*. The fixing/jointing clips are fabricated, and stop ends and external corners injection moulded. Internal corners are abutted.

The system is designed to absorb impact in three ways, as shown.

### Three Way Impact Reaction

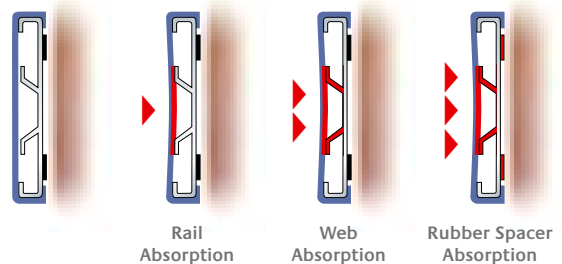

## Dimensions

The rail is extruded in lengths of 3.5m, has a projection of 30mm, and is 200mm, 125mm or 75mm wide.

## Colours and Finishes

Standard colours are shown on pages 60 & 61. Special colours are available subject to order quantity or premium.

The face of the rail has a Stippled finish to help conceal the effects of impact and abrasion.



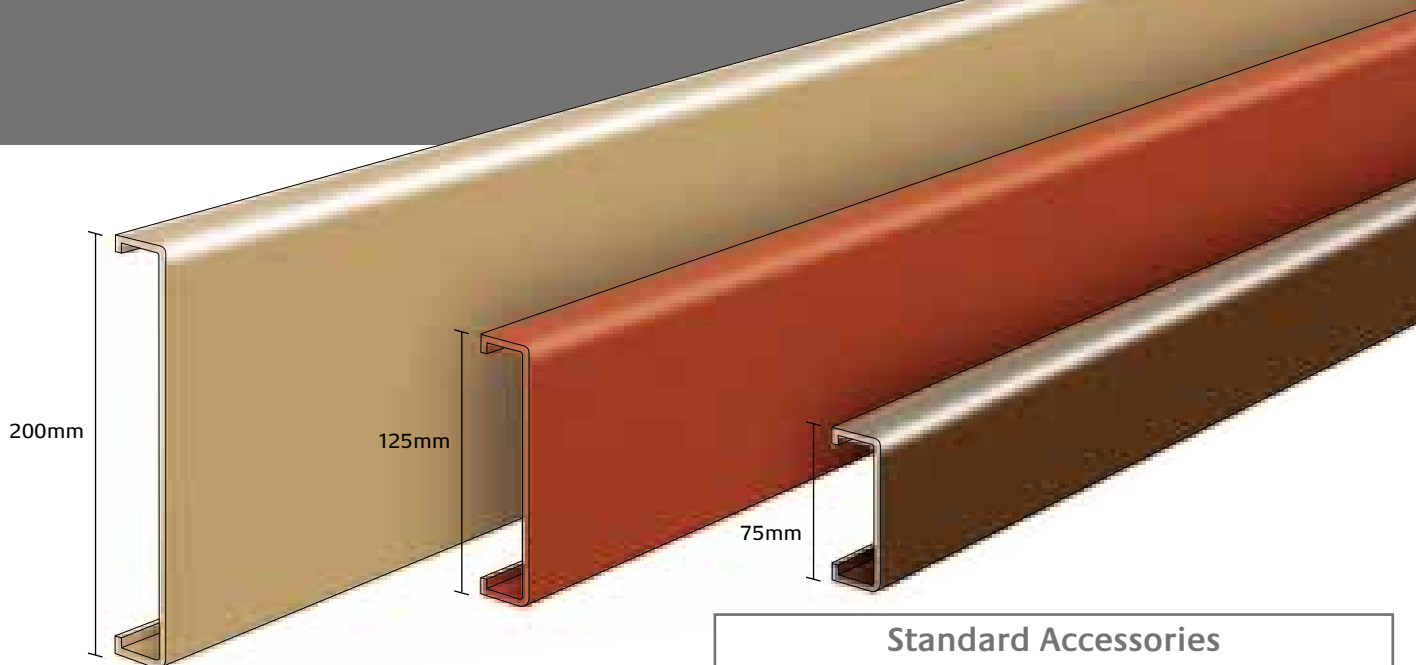

### Standard Accessories

200mm accessories are as shown. The design of the fixing/jointing clip differs slightly on the 125mm and 75mm rails.

Timber, Steel and Vinylac cores are available (see illustrations).

### Special Accessories

Irregular external corners are manufactured to order.

A continuous pre-formed core is recommended in areas where the rail may be subject to heavier impact. In extreme instances of impact it may also be advisable to utilise the steel style stop ends and corners.

When spanning windows or radiators, a continuous steel core should be used.

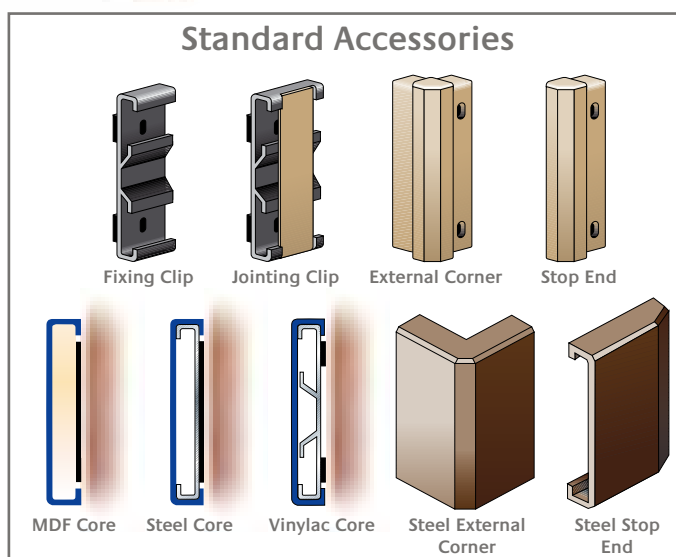

### Installation

Instructions are for Protection Rail on fixing clips. (Where core is used, then neither fixing clips nor jointing clips are required. Core must be fixed at maximum 800mm centres, through rubber spacers).

Mark the pre-determined height of the rail on the surface to be protected. Screw stop ends and jointing clips into position. Screw fixing clips at maximum 700mm centres, using the appropriate fixings as suggested in table. External corners are **not** screw fixed.

Where an external corner occurs, screw fixing clips on adjacent faces 100mm from the angle. For an internal corner,

screw a fixing clip on each face 50mm from the angle. Cut the rail where necessary with a fine tooth tenon saw, all ends must be cut square. Snap the rail into place over the fixing/jointing clips and accessory spigots. Glue the external corner into one end of the pre-positioned rail, and then snap the adjacent rail into position.

N.B. Shape of clip differs on 125mm and 75mm rails.

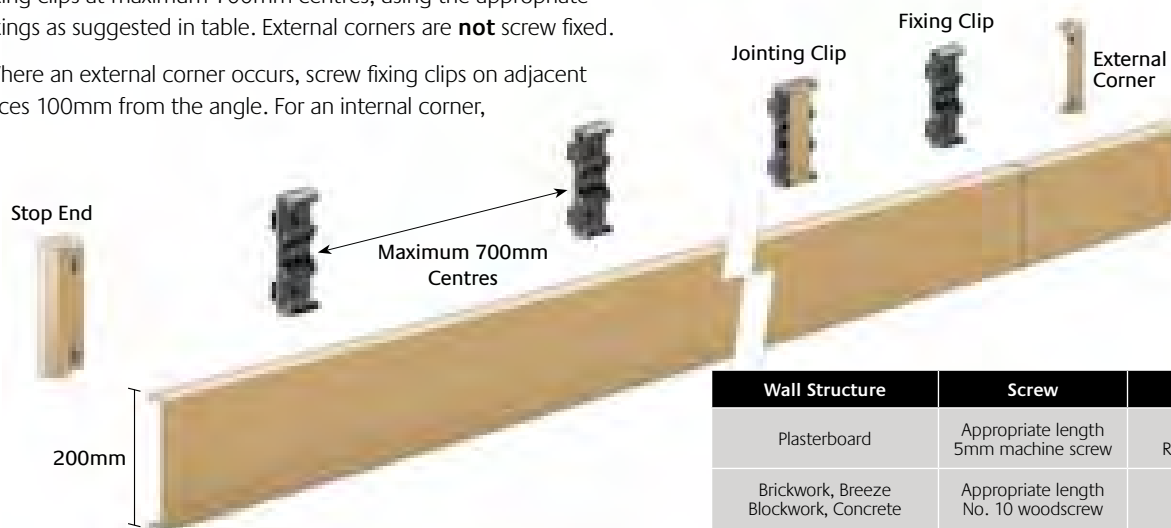

| Wall Structure                                 | Screw                                | Plug                    |
|--|--------------------------------------|-------------------------|
| Plasterboard                                   | Appropriate length 5mm machine screw | 5mm Rubber Rawlnut      |
| Brickwork, Breeze Blockwork, Concrete          | Appropriate length No. 10 woodscrew  | No. 10 Plastic plug     |
| Lightweight Blockwork e.g. Thermalite, Siporex | Appropriate length No. 10 woodscrew  | Fischer S8 Plastic plug |
| Steel  | Self-tapper                          | -                       |

\* Please see information on pages 62 & 63.



# ULTRA 60 & 40 RAIL

The design of Yeoman Shield Ultra Protection Rail subtly incorporates a greater projection that is uncommon in most “back to wall styles.” This attribute allows these rails to protect areas where differing types of trolleys are used, as well as those with protrusions.



## Composition

The extruded rail and accessories are manufactured using Vinylac\*. The fixing/jointing clips are fabricated, and stop ends and external corners injection moulded. Internal corners comprise two stop ends.

The system is designed to absorb impact in three ways, as shown.

### Three Way Impact Reaction

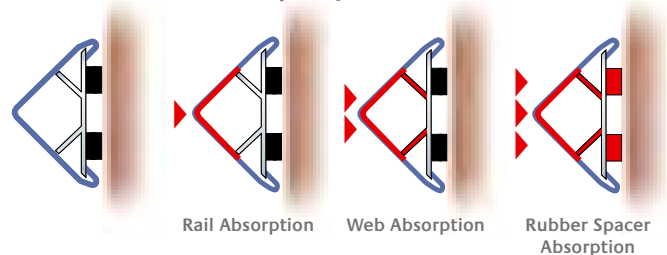

## Dimensions

The rail is extruded in lengths of 3.5m. Ultra 60 has a projection of 60mm and is 90mm deep. Ultra 40 has a projection of 40mm and is 120mm deep.

## Colours and Finishes

Standard colours are shown on pages 60 & 61. Special colours are available subject to order quantity or premium.

The face of the rail has a Stippled finish to help conceal the effects of impact and abrasion.

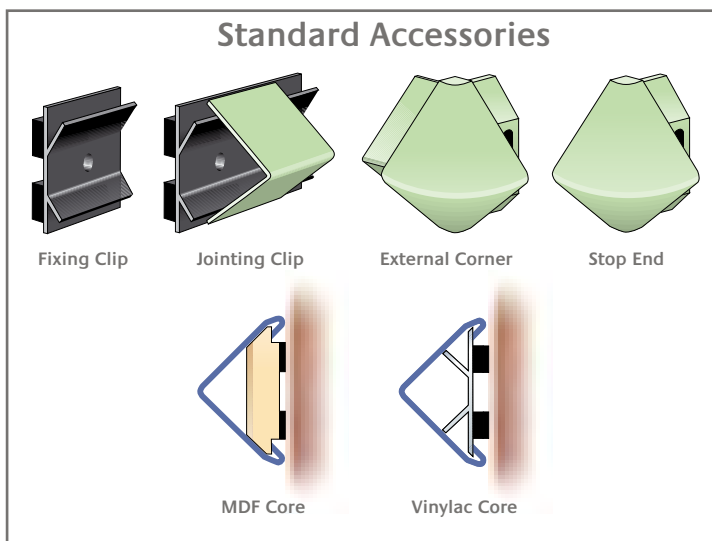
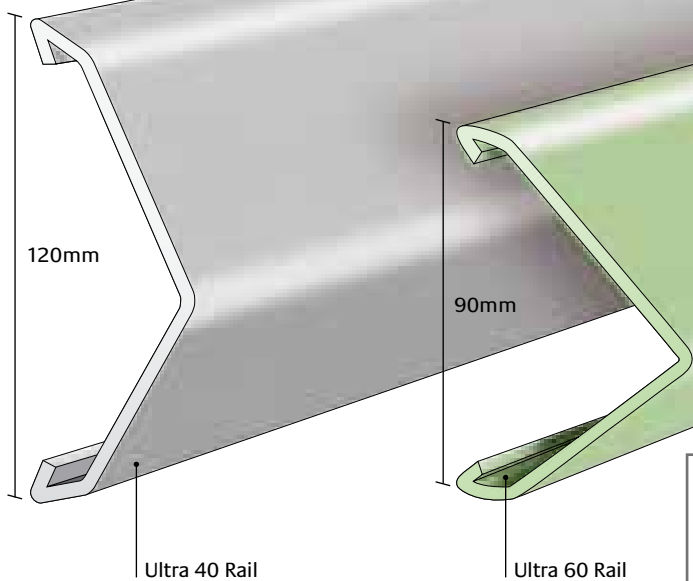

**Standard Accessories** - As shown.

Timber and Vinylac cores are available (see illustrations).

**Special Accessories**

A continuous pre-formed core is recommended in areas where the rail may be subject to heavier impact, or when spanning windows or radiators.

**Installation**

Instructions are for Ultra Rail on fixing clips. (Where core is used, then neither fixing clips nor jointing clips are required. Core must be fixed at maximum 800mm centres, through rubber spacers).

Mark the pre-determined height of the rail on the surface to be protected. Screw stop ends and jointing clips into position. Screw fixing clips at maximum 700mm centres, using the appropriate fixings as suggested in table. External corners are **not** screw fixed.

Where an external corner occurs, screw fixing clips on adjacent faces 100mm from the angle. For an internal corner, screw a fixing clip on each face 50mm from the angle.

Cut the rail where necessary with a fine tooth tenon saw, all ends must be cut square. Snap the rail into place over the fixing/jointing clips and accessory spigots. Glue the external corner into one end of the pre-positioned rail, and then snap the adjacent rail into position.

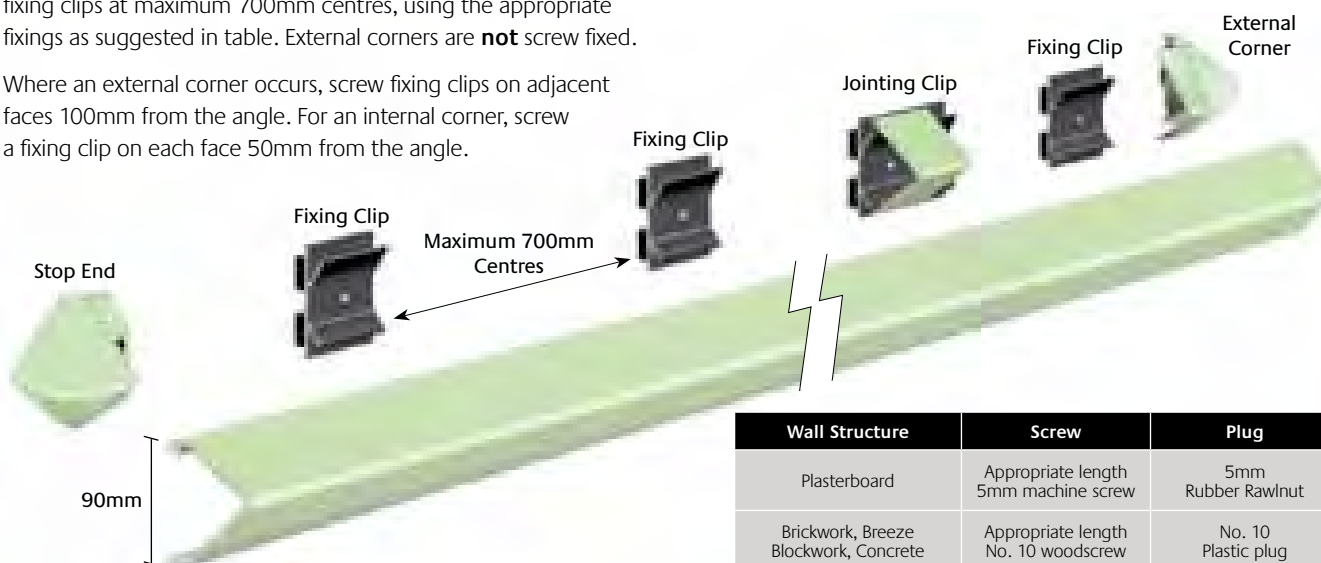

| Wall Structure                                 | Screw                                | Plug                    |
|--|--------------------------------------|-------------------------|
| Plasterboard                                   | Appropriate length 5mm machine screw | 5mm Rubber Rawlnut      |
| Brickwork, Breeze Blockwork, Concrete          | Appropriate length No. 10 woodscrew  | No. 10 Plastic plug     |
| Lightweight Blockwork e.g. Thermalite, Siporex | Appropriate length No. 10 woodscrew  | Fischer S8 Plastic plug |
| Steel  | Self-tapper                          | -                       |

\* Please see information on pages 62 & 63.



# 200 & 125 CONTRA RAIL

Yeoman Shield Contra Protection Rail delivers an extra dimension in design. It includes a recess into which a feature strip is fitted, offering the added benefit of a further choice of colours and attractive two-tone finish to complement interiors.



## Composition

The extruded rail and accessories are manufactured using Vinylac\*. The fixing/jointing clips are fabricated, and stop ends and external corners injection moulded. Internal corners are abutted.

The system is designed to absorb impact in three ways, as shown.

### Three Way Impact Reaction

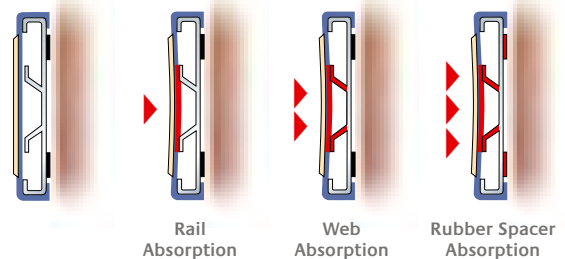

## Dimensions

The rail is extruded in lengths of 3.5m, has a projection of 32mm, and is 200mm or 125mm wide. The colour-contrasting insert is 50mm narrower than the rail.

## Colours and Finishes

The rail has a smooth finish and is supplied in Mid Grey as standard. Special colours are available subject to order quantity or premium.

Standard colours for the insert are shown on pages 60 & 61.

The insert is available in a range of finishes to help conceal the effects of impact and abrasion, including FalmouthEx, HessianEx and Stippled.

## Special Information

Signage can be incorporated within rails.

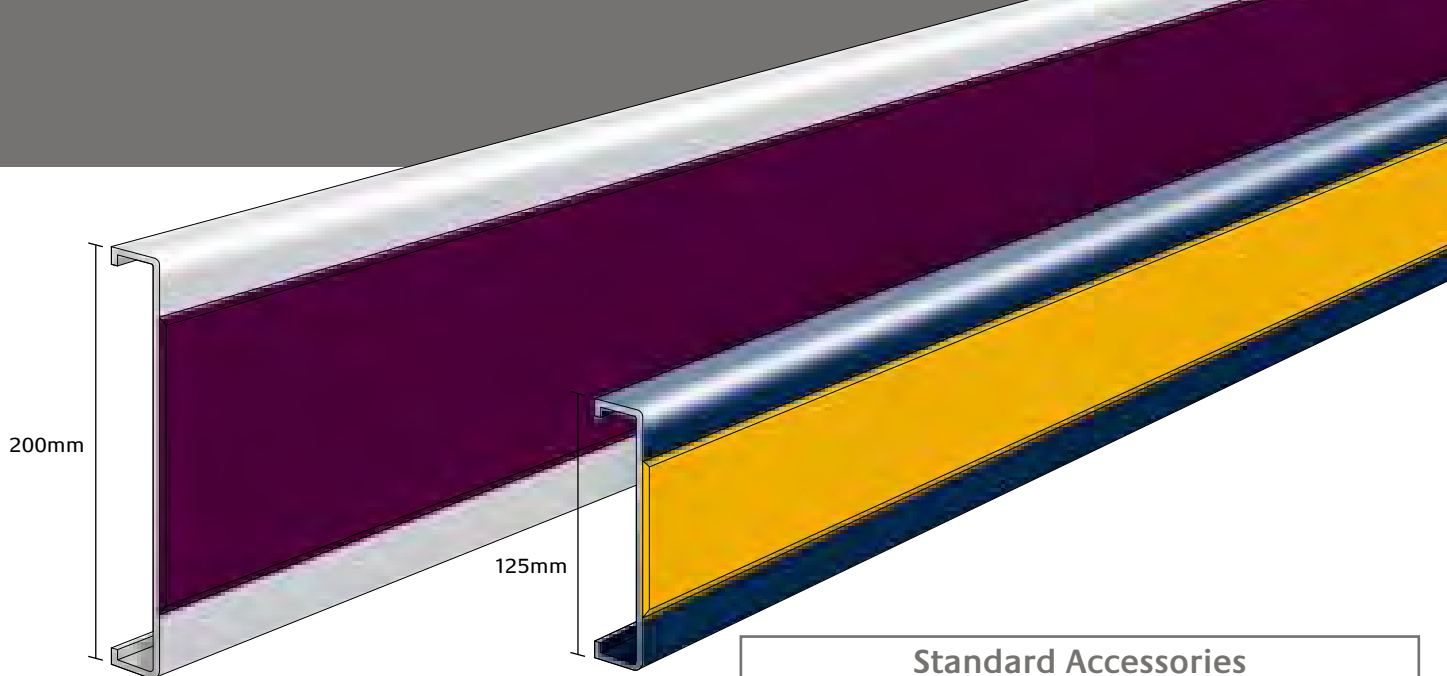

### Standard Accessories

200mm accessories are as shown. The design of the fixing/jointing clip differs slightly on the 125mm rail.

Timber, Steel and Vinylac cores are available (see illustrations).

### Special Accessories

Irregular external corners are manufactured to order.

A continuous pre-formed core is recommended in areas where the rail may be subject to heavier impact. In extreme instances of impact it may also be advisable to utilise the steel style stop ends and angles.

When spanning windows or radiators, a continuous steel core should be used.

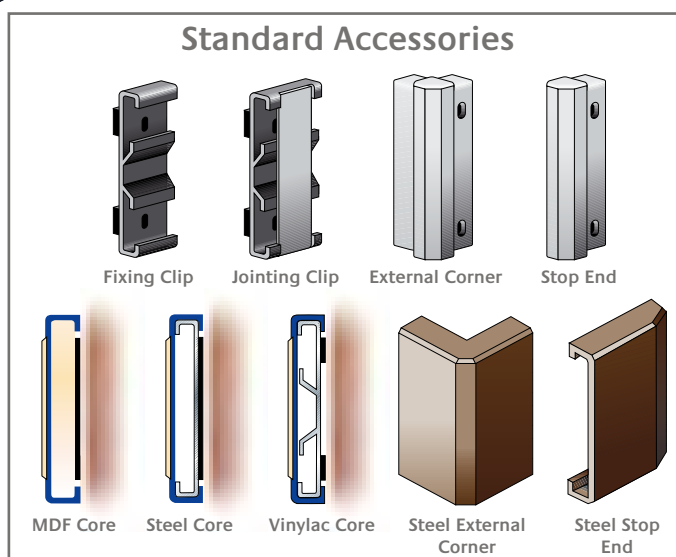

### Installation

Instructions are for Contra Rail on fixing clips. (Where core is used, then neither fixing clips nor jointing clips are required. Core must be fixed at maximum 800mm centres, through rubber spacers).

Mark the pre-determined height of the rail on the surface to be protected. Screw stop ends and jointing clips into position. Screw fixing clips at maximum 700mm centres, using the appropriate fixings as suggested in table. External corners are **not** screw fixed.

Where an external corner occurs, screw fixing clips on adjacent faces 100mm from the angle. For an internal corner, screw a fixing clip on each face 50mm from the angle. Cut the rail, where necessary, with a fine tooth tenon saw, all ends must be cut square.

Snap the rail into place over the fixing/jointing clips and accessory spigots. Glue the external corner into one end of the pre-positioned rail, and then snap the adjacent rail into position.

Finally, adhere the pre-taped Vinylac insert into place. Position joints in insert away from rail joints for aesthetic reasons.

N.B. Shape of clip differs on 125mm rail.

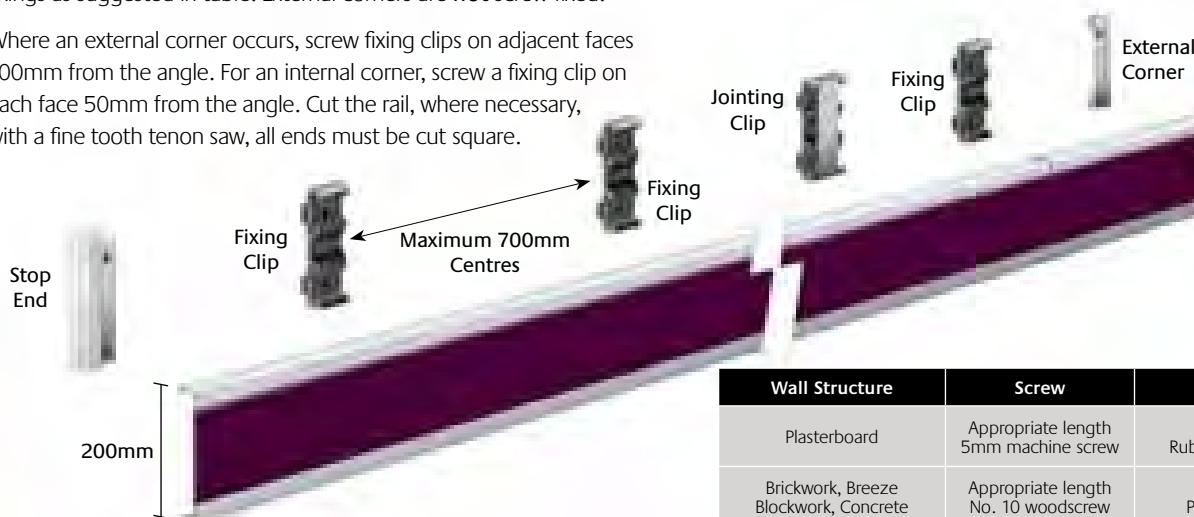

| Wall Structure                                 | Screw                                | Plug                    |
|--|--------------------------------------|-------------------------|
| Plasterboard                                   | Appropriate length 5mm machine screw | 5mm Rubber Rawlnut      |
| Brickwork, Breeze Blockwork, Concrete          | Appropriate length No. 10 woodscrew  | No. 10 Plastic plug     |
| Lightweight Blockwork e.g. Thermalite, Siporex | Appropriate length No. 10 woodscrew  | Fischer S8 Plastic plug |
| Steel  | Self-tapper                          | -                       |

\* Please see information on pages 62 & 63.



# PREMIER PROTECTION RAIL

Yeoman Shield Premier Protection Rail hides its functionality in pure aesthetics. It has the appearance of a decorative feature although it is a fully operational protection rail. It is ideal for those areas where corporate image is a major consideration.



## Composition

The system has a Vinylac\* face, edged with high quality Ash trims.

The rail takes its strength from a pre-formed MDF backing core.

Premier Protection Rail meets the requirements of HTM 69, please see further details on page 62.

## Dimensions

The rail is 200mm wide, as standard, and has a projection of 20mm. It is workshop manufactured to suit site sizes. Lengths over 2.44m are jointed on site.

N.B. The rail can be manufactured to your specified width.

## Colours and Finishes

Standard colours for the insert are shown on pages 60 & 61. Special colours are available subject to order quantity or premium.

The insert is available in a range of finishes to help conceal the effects of impact and abrasion. The standard finish is FalmouthEx and alternatives include HessianEx and Stippled.

## Special Information

Signage can be incorporated within rails.



### Standard Accessories

Ash stop ends are an integral part of the system. External corners are mitred, but the Vinylac insert is fabricated for continuity. Internal corners are also mitred, the Vinylac insert is cut and fitted.

### Special Accessories

Irregular external/internal corners are manufactured to order. Alternative trims are available to order. Please contact our Sales Office for further information.



### Installation

Premier Protection Rail is manufactured in our workshops to suit site sizes. We require full site dimensions and layout drawings to be provided, showing the positions of stop ends, internal and external corners and advising degree of all irregulars.

Mark the pre-determined height of the rail on the surface to be protected and screw fix at maximum 800mm centres, using the appropriate fixings as suggested in table.

When the core rail is secured, adhere the pre-taped Vinylac insert into place. Joints between insert should be positioned away from joints in core rail for aesthetic reasons.

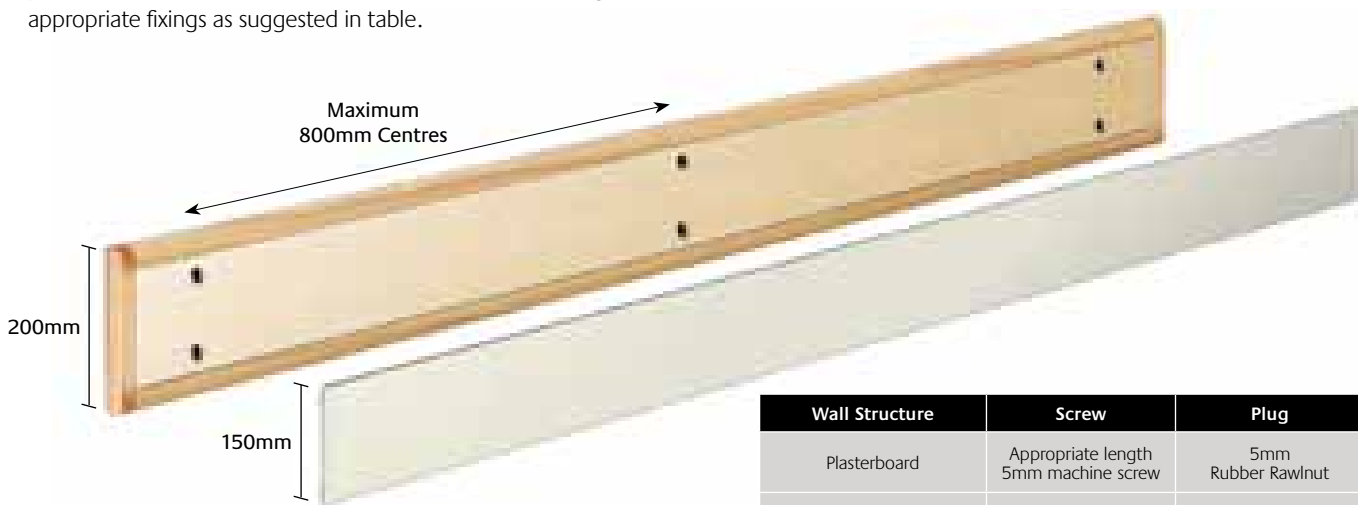

| Wall Structure                                 | Screw                                | Plug                    |
|--|--------------------------------------|-------------------------|
| Plasterboard                                   | Appropriate length 5mm machine screw | 5mm Rubber Rawlnut      |
| Brickwork, Breeze Blockwork, Concrete          | Appropriate length No. 10 woodscrew  | No. 10 Plastic plug     |
| Lightweight Blockwork e.g. Thermalite, Siporex | Appropriate length No. 10 woodscrew  | Fischer S8 Plastic plug |
| Steel  | Self-tapper                          | -                       |

\* Please see information on pages 62 & 63.



# RIGI, FLEXI & MAXI RAIL

Yeoman Shield Rigi, Flexi and Maxi Rails are durable, attractive and functional. Each has been specifically designed to meet the demands of retail environments, such as supermarkets, and are the ideal choice for preventing damage from supermarket trolleys and baskets.



## Composition

The systems are manufactured using extruded PVCu for both the cover and continuous fixing track. Rigi Rail and Maxi Rail are rigid, whilst the Flexi Rail is flexible.

Stop ends and corners for all systems are injection moulded. Internal corners comprise of two stop ends.

## Dimensions

The rails are extruded in lengths of 3.5m. Rigi and Flexi Rails have a projection of 30mm and a depth of 50mm. Maxi Rail has a projection of 50mm and a depth of 60mm.

Some smaller sections of Rigi and Flexi Rails, 30mm projection and 40mm or 30mm deep, are available in limited colours. Please contact our Sales Office for further details.

## Colours and Finishes

These rails have a smooth finish and are currently available in the colours shown below. Special colours are available subject to order quantity or premium.

| COLOUR       | BS/RAL No. | Rigi | Flexi | Maxi |
|--------------|------------|------|-------|------|
| Black        | BS 00 E 53 | ✓    | ✓     | ✓    |
| Mid Grey     | BS 00 A 05 | ✓    | ✓     | ✓    |
| Buff         | RAL 1001   | ✓    | ✓     | ✓    |
| Brown        | BS 08 B 29 | ✓    | ✓     | -    |
| Regatta Blue | BS 18 E 53 | ✓    | ✓     | -    |
| Red          | BS 04 E 53 | ✓    | ✓     | -    |
| White        | RAL 9016   | -    | -     | ✓    |
| Pastel Blue  | RAL 5024   | -    | -     | ✓    |
| Silver       | -          | -    | -     | ✓    |
| Dark Grey    | RAL 7015   | ✓    | ✓     | -    |
| Opal Green   | RAL 6004   | -    | ✓     | -    |
| Steel Blue   | RAL 5011   | ✓    | ✓     | -    |



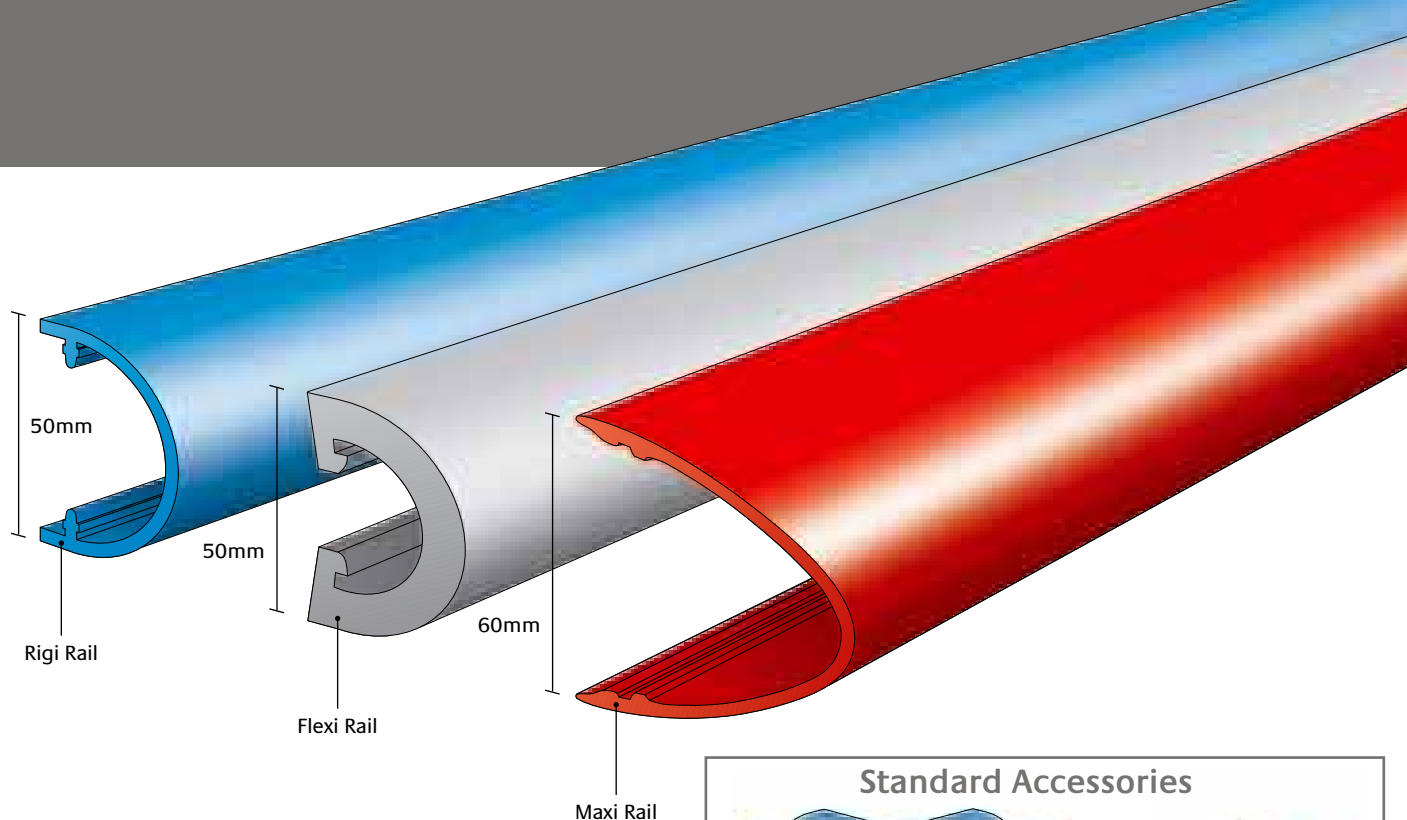

### Standard Accessories

Rigi and Flexi Rail accessories are shown. The Maxi Rail accessories differ slightly.

### Special Accessories

Irregular external/internal corners are manufactured to order.

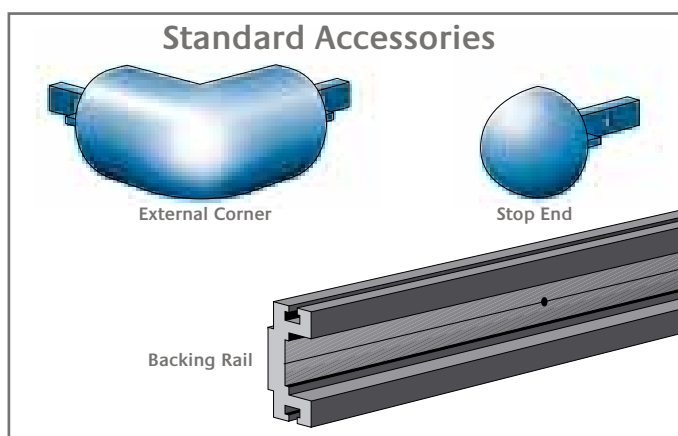

### Installation

Instructions are for Rigi Rail, track differs slightly for Flexi and Maxi Rails, but are similar for all three sections.

Mark the pre-determined height of the rail on the surface to be protected. Secure the backing rail at maximum 150mm centres, using the appropriate fixings as suggested in table. Screw stop ends into position through the backing rail.

Cut the rail to size with a fine tooth tenon saw, all ends must be cut square, and clip into position. Where a corner is required, fix

the corner into one end of the pre-positioned rail and then clip the adjacent rail into position.

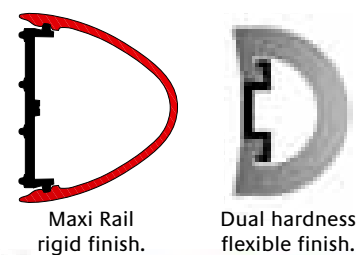

| Wall Structure                                 | Screw                                | Plug                    |
|--|--------------------------------------|-------------------------|
| Plasterboard                                   | Appropriate length 5mm machine screw | 5mm Rubber Rawlnut      |
| Brickwork, Breeze Blockwork, Concrete          | Appropriate length No. 10 woodscrew  | No. 10 Plastic plug     |
| Lightweight Blockwork e.g. Thermalite, Siporex | Appropriate length No. 10 woodscrew  | Fischer S8 Plastic plug |
| Steel  | Self-tapper                          | -                       |

\* Please see information on pages 62 & 63.



# GUARDIAN HANDRAIL

Yeoman Shield Guardian Handrail has strength and style. It neatly combines a rounded grip-top handrail and a protection rail.

The option of fitting a colour-contrasting insert offers an additional stylish effect.



## Composition

The extruded rail and accessories are manufactured using Vinylac\*. Wall return ends, internal and external corners are injection moulded.

The rail takes its strength from a pre-formed MDF core, and is fitted to standard 60mm Cream PVCu spacers.

## Dimensions

The 40mm diameter "grip-top" rail is extruded in lengths of 3.5m, has a projection of 80mm when fitted on standard Cream spacers and is 125mm deep.

Guardian Handrail does not contravene the DDA Regulations, please see further details on page 62.

## Colours and Finishes

Standard colours are shown on pages 60 & 61. Special colours are available subject to order quantity or premium. Spacers are Cream.

The face of the rail has a Stippled finish to help conceal the effects of impact and abrasion.

N.B. The system is also available as a two-tone Contra Rail utilising a 75mm contrasting feature strip. The rail has a smooth finish and is supplied in Mid Grey as standard. Special colours are available subject to order quantity or premium.

The insert is available in a range of finishes to help conceal the effects of impact and abrasion, including FalmouthEx, HessianEx and Stippled.

## Special Information

Signage can be incorporated within rails.

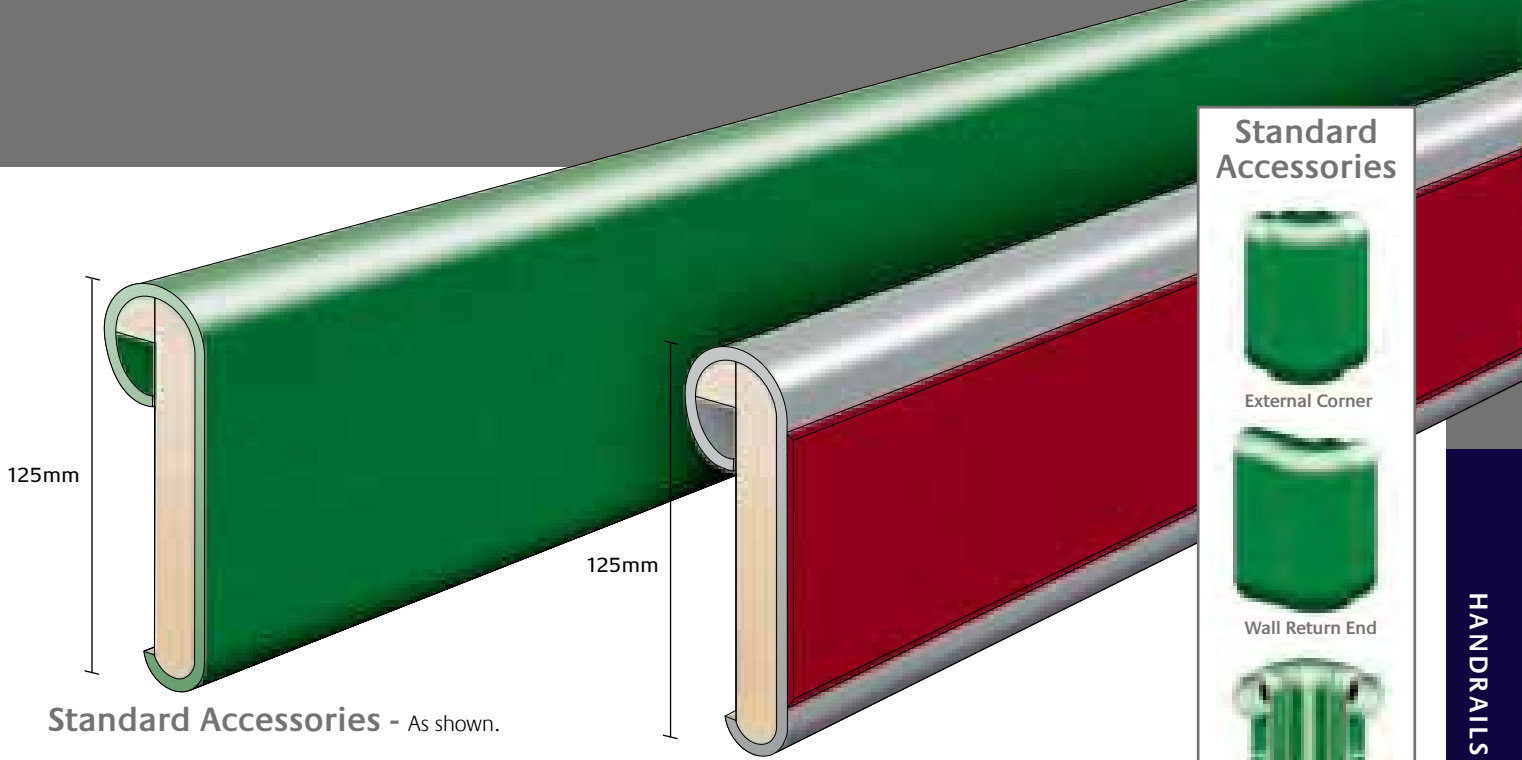

**Standard Accessories** - As shown.

**Special Accessories**

Irregular external/internal corners are manufactured to order.  
 PVCu and metal spacers of differing projections are available.



**Installation**

Each spacer bracket should be sited long side across (as shown) on the wall, 50mm below the intended height of the handrail. This dimension is to top of spacer, completed with the PVCu cover. Spacers should be positioned maximum 200mm to centre at wall return ends/internal corners and 150mm to centre at external corners.

Mark the pre-determined position of the remaining spacer brackets on the surface to receive the rail at maximum 800mm centres. Each length of handrail must be supported by a minimum of two spacer brackets. Screw spacers into position, using the appropriate fixings as suggested in table.

Position the wall fixing plate in line with the wall return ends, mark the fixing holes, drill and secure into position using the appropriate fixings.

Cut the MDF core to the required length, allowing for wall return ends and corners, and screw it to the spacer brackets. Joints in core must occur on a spacer.

Cut the required length of Vinylac cover using a fine tooth tenon saw, all ends must be cut square, and present it to the core with the face at right angles to the wall.

Locate top clip-on and lower to snap over core, progressing from one end until complete. Each length of Vinylac cover should be restrained by applying a bead of silicone adhesive at one end.

Fit wall returns into position using adhesive. At an internal/external corner clip on one rail, fit the corner piece using adhesive, then clip on the adjacent rail.

Where relevant, adhere the pre-taped insert into place. Position joints in insert away from rail joints for aesthetic reasons.

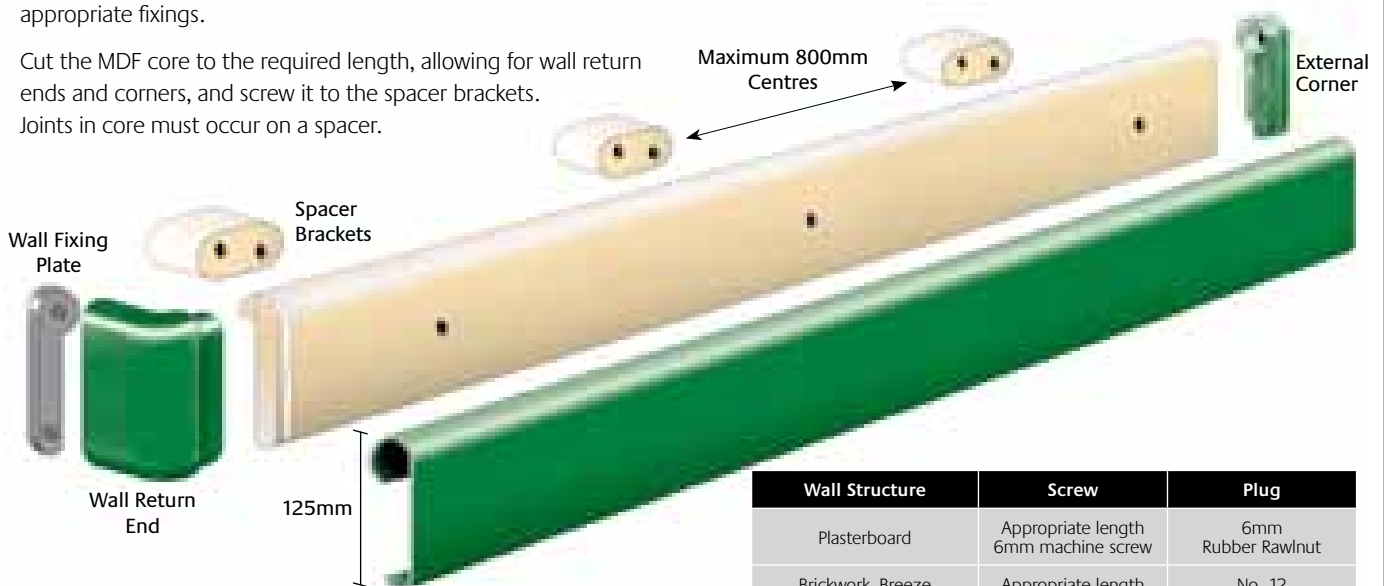

| Wall Structure                                 | Screw                                | Plug                      |
|--|--------------------------------------|---------------------------|
| Plasterboard                                   | Appropriate length 6mm machine screw | 6mm Rubber Rawlnut        |
| Brickwork, Breeze Blockwork, Concrete          | Appropriate length No. 12 woodscrew  | No. 12 Plastic plug       |
| Lightweight Blockwork e.g. Thermalite, Siporex | Appropriate length No. 12 woodscrew  | Fischer GB10 Plastic plug |
| Steel  | Self-tapper                          | -                         |

\* Please see information on pages 62 & 63.



# PREMIER HANDRAIL

Yeoman Shield Premier Handrail caters for a select market where image and aesthetics, combined with the function of a protective handrail, are a priority.



## Composition

The system has a Vinylac\* face, edged with high quality Ash trims. The rail takes its strength from a pre-formed MDF backing core, and is fitted to standard 55mm Cream PVCu spacers.

Premier Handrail meets the requirements of HTM 69, please see further details on page 62.

## Dimensions

The rail is 200mm wide, as standard, and has a projection of 75mm when fitted on standard Cream spacers. It is workshop manufactured to suit site sizes. Lengths over 2.44m are jointed on site on spacers.

N.B. The rail can be manufactured to your specified width.

## Colours and Finishes

Standard colours for the insert are shown on pages 60 & 61. Special colours are available subject to order quantity or premium. Spacers are Cream.

The insert is available in a range of finishes to help conceal the effects of impact and abrasion. The standard finish is FalmouthEx and alternatives include HessianEx and Stippled.

## Special Information

Signage can be incorporated within rails.

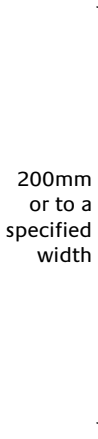

### Standard Accessories

Ash stop ends are an integral part of the system. External corners are mitred, but the Vinylac insert is fabricated for continuity. Internal corners are also mitred, the Vinylac insert is cut and fitted.

### Special Accessories

Irregular external/internal corners are manufactured to order. Alternative trims are available to order. Please contact our Sales Office for further information. PVCu and metal spacers of differing projections are available.

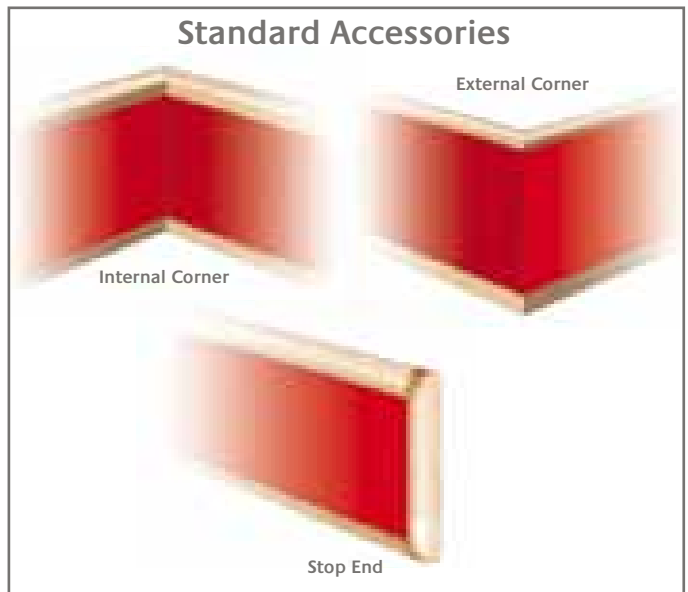

### Installation

Premier Handrail is manufactured in our workshops to suit site sizes. We require full site dimensions and layout drawings to be provided, showing the positions of stop ends, internal and external corners and advising degree of all irregulars.

Each spacer bracket should be sited on the wall 50mm below the intended height of the handrail. Spacers should be positioned maximum 200mm to centre at stop ends, internal corners and external corners. Joints in core rail must occur on spacers.

Mark the pre-determined position of the remaining spacer brackets at maximum 800mm centres and

screw into position, using the appropriate fixings as suggested in table. Each length of handrail must be supported by a minimum of two spacer brackets.

Secure the lengths of MDF core to the spacer brackets and adhere the pre-taped Vinylac insert into place. Joints between insert should be positioned away from joints in core rail for aesthetic reasons.

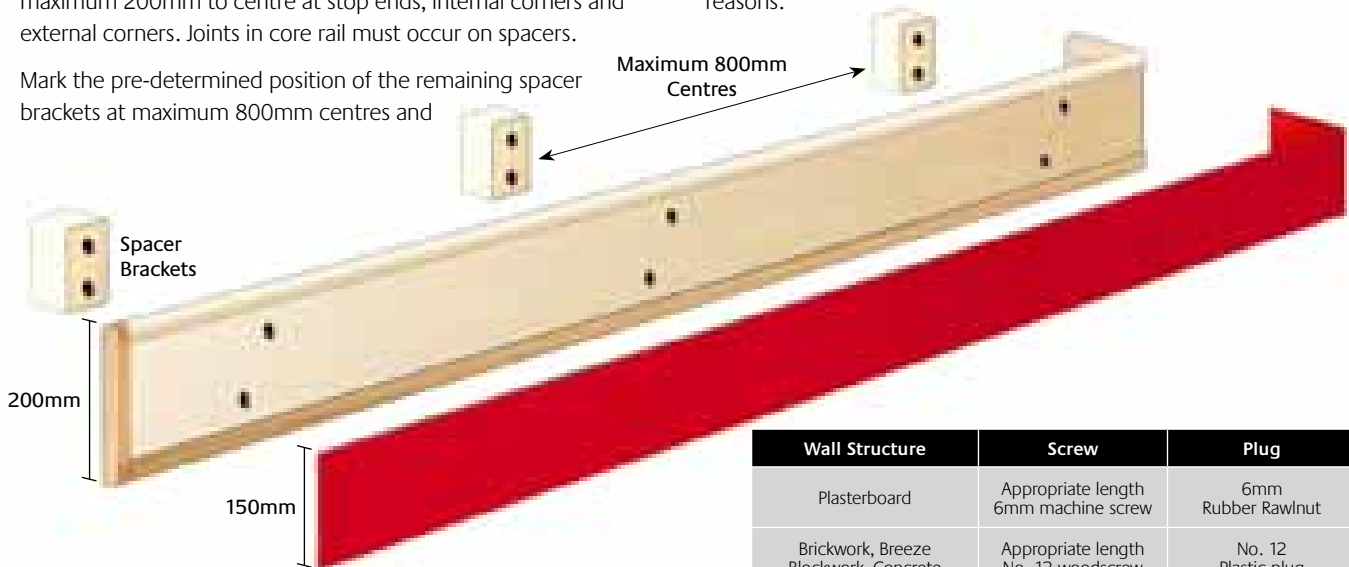

| Wall Structure                                 | Screw                                | Plug                      |
|--|--------------------------------------|---------------------------|
| Plasterboard                                   | Appropriate length 6mm machine screw | 6mm Rubber Rawlnut        |
| Brickwork, Breeze Blockwork, Concrete          | Appropriate length No. 12 woodscrew  | No. 12 Plastic plug       |
| Lightweight Blockwork e.g. Thermalite, Siporex | Appropriate length No. 12 woodscrew  | Fischer GB10 Plastic plug |
| Steel  | Self-tapper                          | -                         |

\* Please see information on pages 62 & 63.



# COMBINED HANDRAIL/ PROTECTION RAIL

Originally an adaptation of the standard Protection Rail, Yeoman Shield Combined Handrail/Protection Rail is still very popular today. However, the introduction of the purpose designed Guardian and Premier Handrails has resulted in this system being mainly employed as a protection against the more heavily laden trolleys.



## Composition

The extruded rail is manufactured using Vinylac\*, and the stop ends and external corners are injection moulded.

The rail takes its strength from a pre-formed MDF core and is fitted to standard 55mm Cream PVCu spacers.

Combined Handrail/Protection Rail meets the requirements of HTM 69, please see further details on page 62.

## Dimensions

The rail is extruded in lengths of 3.5m, has a projection of 83mm, when fitted on standard Cream spacers, and is 200mm, 125mm or 75mm wide.

## Colours and Finishes

Standard colours are shown on page 60 & 61. Special colours are available subject to order quantity or premium. Spacers are Cream.

The face of the rail has a Stippled finish to help conceal the effects of impact and abrasion.

N.B. The system is also available as a two-tone Contra Rail in 200mm and 125mm widths. The colour contrasting insert is 50mm narrower than the rail. The rail has a smooth finish and is supplied in Mid-Grey as standard. Special colours are available subject to order quantity or premium.

The insert is available in a range of finishes to help conceal the effects of impact and abrasion, including FalmouthEx, HessianEx and Stippled.

## Special Information

Signage can be incorporated within rails.

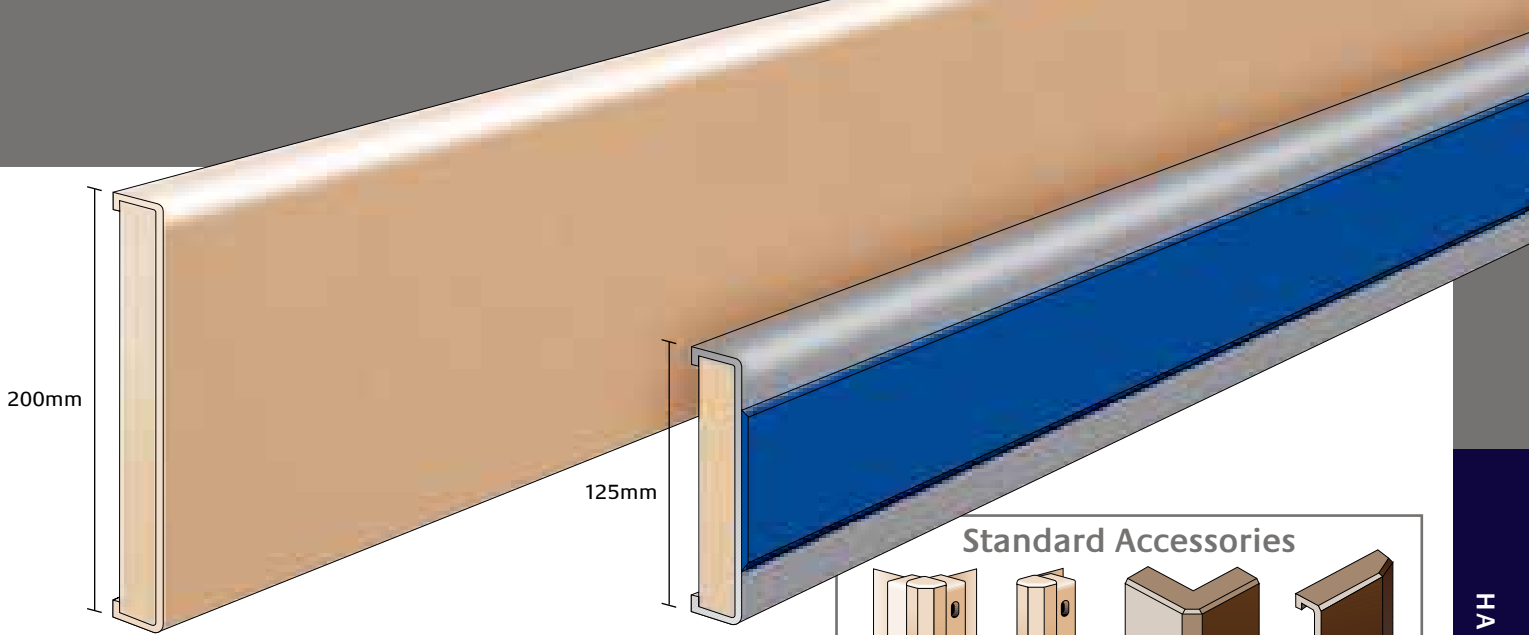

### Standard Accessories

200mm accessories are as shown.

Timber, Steel and Vinylac cores are also available (see illustrations).

### Special Accessories

Irregular external corners are manufactured to order.

In extreme instances of impact it may be advisable to utilise the steel style stop ends and corners.

When spanning windows or radiators, a continuous steel core should be used.

PVCu and metal spacers of differing projections are available.

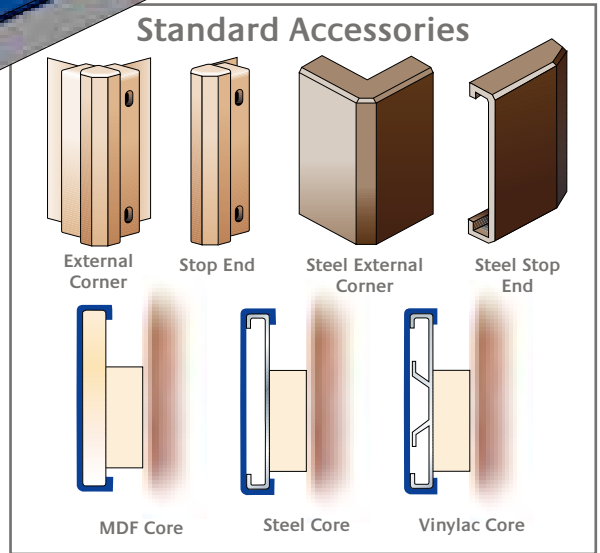

### Installation

Each spacer bracket should be sited on the wall 50mm below the intended height of the handrail. Spacers should be positioned maximum 200mm to centre at stop ends, internal corners and external corners.

Mark the pre-determined position of the remaining spacer brackets on the surface to receive the rail at maximum 800mm centres, screw spacers into position, using the appropriate fixings as suggested in table. Each length of handrail must be supported by a minimum of two spacer brackets.

Cut the MDF core to the required length, allowing for stop ends and corners, and screw it to the spacer brackets. Joints in core must occur on a spacer.

Cut the required length of Vinylac cover using a fine tooth tenon saw, all ends must be cut square, and snap over core, progressing from one end until complete. Glue external corner into one end of the pre-positioned rail, and then snap the adjacent rail into position. Glue stop ends into position.

Where relevant, adhere the pre-taped insert into place. Position joints in insert away from rail joints for aesthetic reasons.

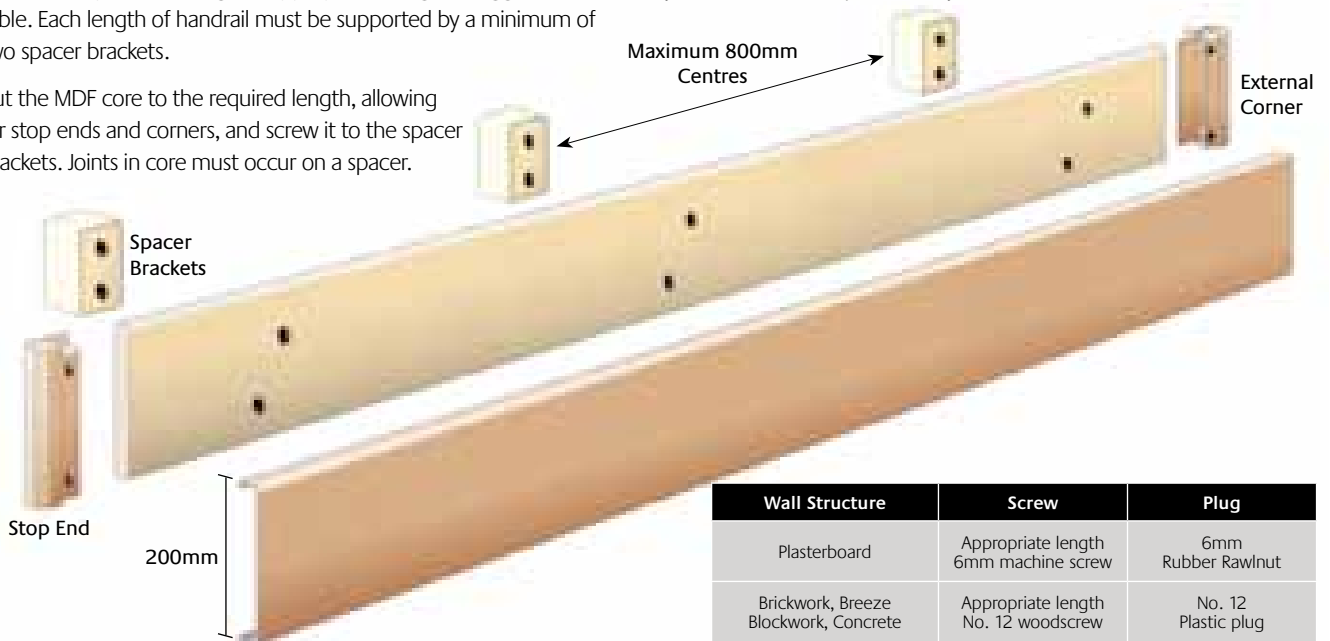

| Wall Structure                                 | Screw                                | Plug                      |
|--|--------------------------------------|---------------------------|
| Plasterboard                                   | Appropriate length 6mm machine screw | 6mm Rubber Rawlnut        |
| Brickwork, Breeze Blockwork, Concrete          | Appropriate length No. 12 woodscrew  | No. 12 Plastic plug       |
| Lightweight Blockwork e.g. Thermalite, Siporex | Appropriate length No. 12 woodscrew  | Fischer GB10 Plastic plug |
| Steel  | Self-tapper                          | -                         |

\* Please see information on pages 62 & 63.



# PROTECTION STRIP

Yeoman Shield Protection Strip is designed to complement Protection Rail and, although normally used to protect doors, can be used as an economical way of protecting walls. It is ideal as a chair rail.



## Composition

The extruded strip is manufactured using Vinylac\*, with the fixing option of double sided adhesive tape or Yeoman Shield mastic adhesive.

## Dimensions

The strip is extruded in lengths of 3.5m. It is 200mm, 125mm or 75mm wide and 3mm thick.

The strip can be supplied in full lengths or cut to size, with or without double sided adhesive tape or Yeoman Shield mastic adhesive.

## Colours and Finishes

Standard colours are shown on pages 60 & 61. Special colours are available subject to order quantity or premium.

The surface of the strip has a Stippled finish to help conceal the effects of impact and abrasion.

Protection Strip may also be manufactured in various widths from Yeoman Shield Wall and Door Protection Panels (see pages 26-27 & 40-41).



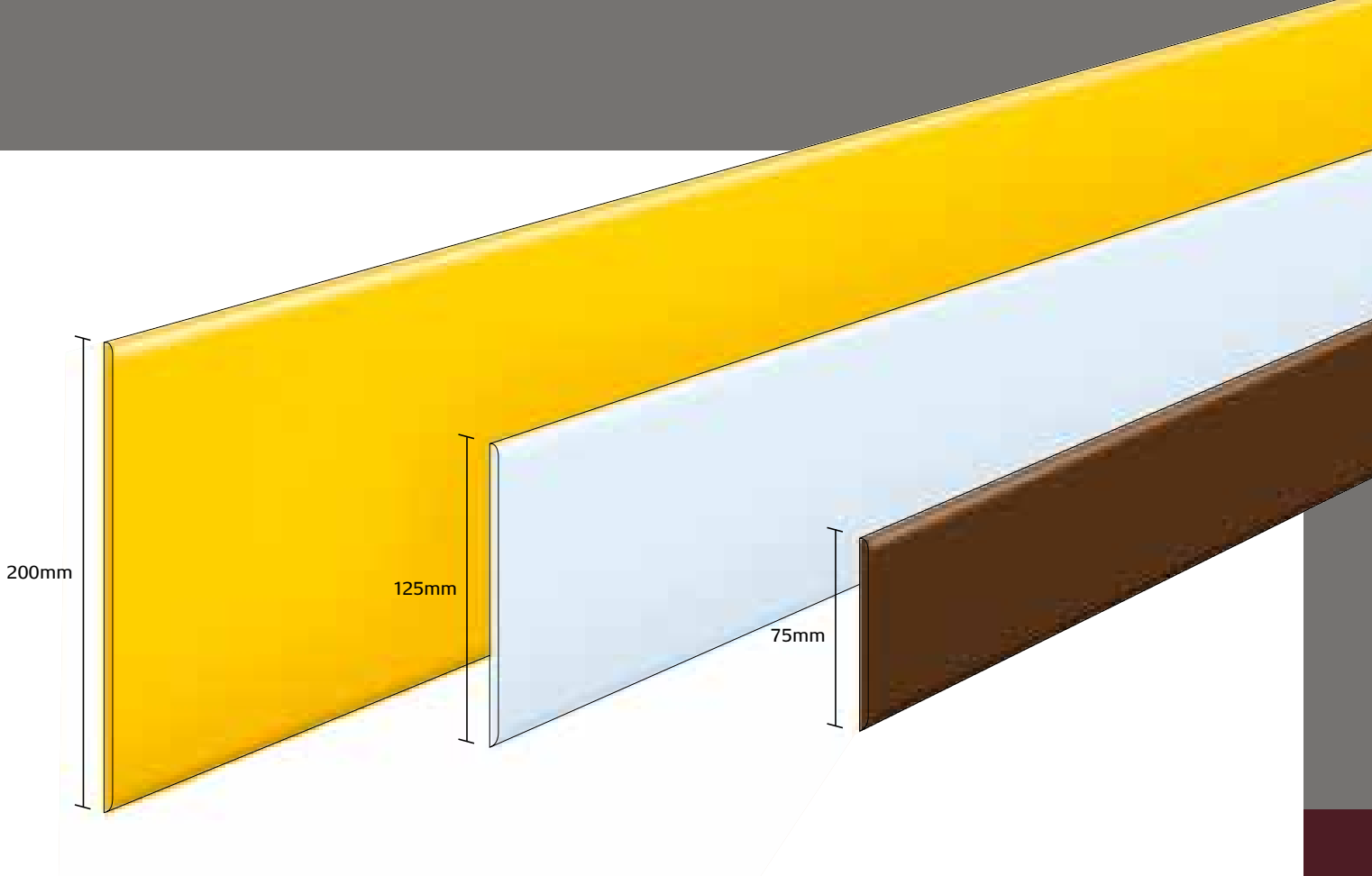

## Installation

When fitting Protection Strip to walls, use either 1mm or 1.6mm double sided adhesive tape depending on the quality of the wall surface. When fitting to doors, we recommend using Yeoman Shield 0.27mm or 0.50mm double sided adhesive tape. However, if the quality of the door surface is poor, a 1mm tape may be more appropriate.

Mark the pre-determined height of the Protection Strip on the surface to be protected and ensure it is primed, clean, free of dust and grease, dry and flat. Wallpapers, where fitted, should be cut back and the wall surface primed to ensure adhesion. (Some wallpapers react and reject adhesive tapes).

Cut the strip to length where necessary (we recommend chamfering the cut edge), peel off the backing paper, place in position and apply pressure to ensure full contact.

If the wall surface is unsuitable for fixing with double sided adhesive tape, we recommend Yeoman Shield mastic adhesive. Screws (and plugs) may be used but slightly oversize holes must be drilled in the strip to allow for movement.





# WALL PROTECTION PANELS

Yeoman Shield Wall Protection Panels offer the complete solution to damage that occurs at varying heights. Panels can be specially formed to fit circular columns or installed floor to ceiling, if necessary. More commonly, panels are fitted above skirting to mid height, where there is the added opportunity to create design features.

Installing wall panels could mean the end of repetitive redecoration and solve the problem of unsightly marks caused by every day knocks and scuffs.



## Composition

Wall panels are manufactured in sheet form using extruded Vinylac\*, with a matching joint cover strip and the fixing option of double sided tape or Yeoman Shield mastic adhesive.

## Dimensions

Standard sheets are 2.500m x 1.250m and held in stock in both 2.0mm and 2.5mm thickness.

Joint cover strips are 50mm wide.

Panels are workshop cut to suit customer requirements, however full sheets may be supplied if required.

Circular Column Protectors can be formed to suit columns of various diameters, height, in one piece or two pieces, complete with joint cover strip/strips.

## Colours and Finishes

Standard colours are shown on pages 60 & 61. Special colours are available subject to order quantity or premium.

Wall Protection Panels are available in two standard finishes to help conceal the effects of impact and abrasion.

FalmouthEx is a light relief pattern, usually supplied 2.0mm thick, whereas HessianEx, 2.5mm thick, is a more decorative finish.

Panels are also available in Toughened Clear non fire rated and smooth White finish, fire rated or non fire rated.

All panels and cover strips are supplied with chamfered edges to ensure a smooth, safe edge is attained once fitted and to avoid any ledges.



## Special Information

Panels can be cut and shaped in many different ways to meet individual requirements and offer greater design capabilities (see pages 28 & 29).

Cutting panels to size often leaves us with stock residue material. It may be possible to meet your requirements for Wall Panels from such residue, at reduced cost.

## Installation

Ensure that the surface to be protected is primed, clean, free of dust and grease, dry and flat.

When fitting Wall Protection Panels, we recommend using either 1mm or 1.6mm double sided adhesive tape depending on the quality of the wall surface.

Any cut outs in the panels for switches, sockets, pipes, etc. should be carried out prior to applying double sided adhesive tape. If the panel is supplied with the tape separate, it should be applied at approximately 3mm from each outside edge of the panel, and around cut outs, and then at maximum 300mm centres.

Peel off the backing paper, place the panel in position and apply pressure to ensure full contact.

Leave a maximum 10mm expansion gap at joints and, if required, fill with clear mastic. Fix the 50mm joint strip to one side of the joint only, overlapping the gap.

If the wall surface is unsuitable for fixing with double sided adhesive tape, we recommend using Yeoman Shield mastic adhesive. A run of double sided adhesive tape should be applied to the top edge of the panelling to hold in position while the mastic cures.

Mastic should be applied in a 6mm bead, either horizontally or vertically, never both, at maximum 150mm centres.

If mechanical fixing is required, screws and plugs may be used but slightly oversize holes must be drilled in the panel to allow for movement.

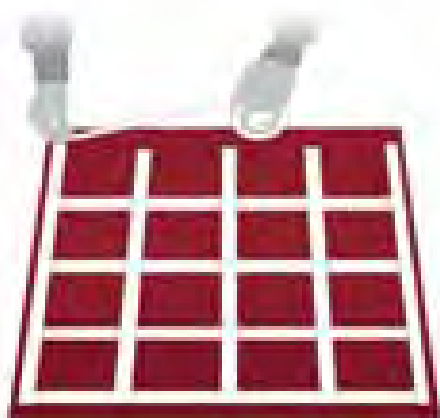



# IMAGERY

In response to the importance of aesthetic consideration in public buildings, Yeoman Shield Imagery unites functional impact protection with mood enhancing designs. Choose a standard design or specify your own - we can cut panels to almost any shape.

Signage (including Braille) can also be incorporated within certain wall protection rails.

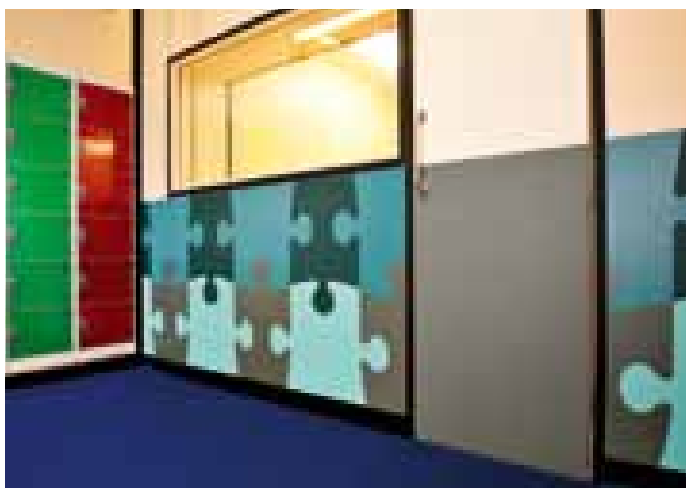

## Composition

Wall panels are manufactured in sheet form using extruded Vinylac\*, with a matching joint cover strip and the fixing option of double sided tape or Yeoman Shield mastic adhesive.

## Dimensions

Standard sheets are 2.500m x 1.250m and held in stock in both 2.0mm and 2.5mm thickness.

Joint cover strips are 50mm wide.

Panels are workshop cut to suit customer requirements, however full sheets may be supplied if required.

## Colours and Finishes

Standard colours are shown on pages 60 & 61. Special colours are available subject to order quantity or premium.

Wall Protection Panels are available in two standard finishes to help conceal the effects of impact and abrasion.

FalmouthEx is a light relief pattern, usually supplied 2.0mm thick, whereas HessianEx, 2.5mm thick, is a more decorative finish.

## Special Information

Panels can be cut and shaped in many different ways to meet individual requirements and offer greater design capabilities.

Cutting panels to size often leaves us with stock residue material. It may be possible to meet your requirements for Wall Panels from such residue, at reduced cost.



## Installation

Ensure that the surface to be protected is primed, clean, free of dust and grease, dry and flat.

When fitting Imagery, we recommend using either 1mm or 1.6mm double sided adhesive tape depending on the quality of the wall surface.

Any cut outs in the panels for switches, sockets, pipes, etc. should be carried out prior to applying double sided adhesive tape. If the panel is supplied with the tape separate, it should be applied at approximately 3mm from each outside edge of the panel, and around cut outs, and then at maximum 300mm centres. Please ensure that sufficient tape is attached to each component of Imagery.

Peel off the backing paper, place the panel in position and apply pressure to ensure full contact.

Imagery is a bespoke range and expansion and contraction will take effect individual to each design. Our sales staff are on hand to advise.

If the wall surface is unsuitable for fixing with double sided adhesive tape, we recommend using Yeoman Shield mastic adhesive. A run of double sided adhesive tape should be applied to the top edge of the panelling to hold in position while the mastic cures.

Mastic should be applied in a 6mm bead, either horizontally or vertically, never both, at maximum 150mm centres.

If mechanical fixing is required, screws and plugs may be used but slightly oversize holes must be drilled in the panel to allow for movement.





# CORNER PROTECTION ANGLES & TRIMS

Yeoman Shield Corner Protection Angles and Trims provide protection to vulnerable corners.

Corner Angles and Trims are available in a range of sizes and materials, designed to protect corners from impact damage caused by either vehicular or pedestrian traffic.

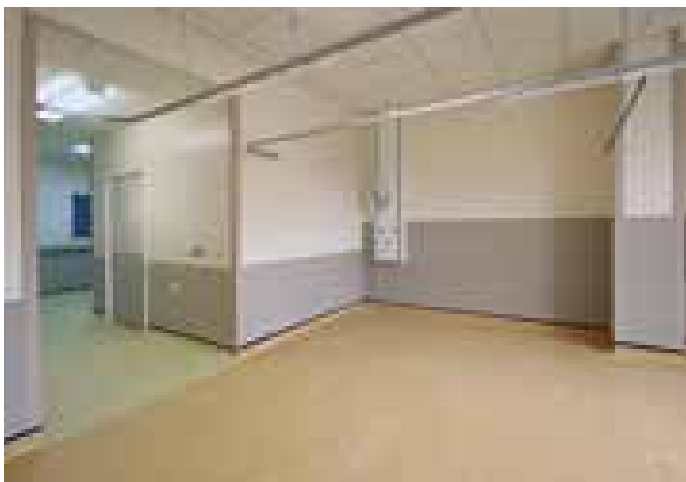

## Composition

Extruded angles and trims are manufactured using Vinylac\*, with the fixing option of double sided adhesive tape or Yeoman Shield mastic adhesive.

## Dimensions

Standard angles are extruded 3mm thick, in lengths of 3.5m, in both 90° and 135°, and the following sizes:

75 x 75mm, 65 x 65mm, 50 x 50mm and 38 x 38mm.

N.B. They are normally supplied in 1.15m units but can be cut to any length.

Standard trims are extruded 2mm thick, in lengths of 3.5m in 90° and the following sizes:

65 x 65mm, 50 x 50mm, 38 x 38mm and 25 x 25mm.

## Colours and Finishes

Standard colours are shown on pages 60 & 61. Special colours are available subject to order quantity or premium.

Standard Corner Protection Angles have a Stippled finish to help conceal the effects of impact and abrasion. Standard Corner Protection Trims have a smooth finish.

## Specials

Corner Protection Angles are available to order, in any size, in Vinylac sheet material, stainless steel, aluminium, brass, mild steel self colour or nylon coated, and clear PVCu.



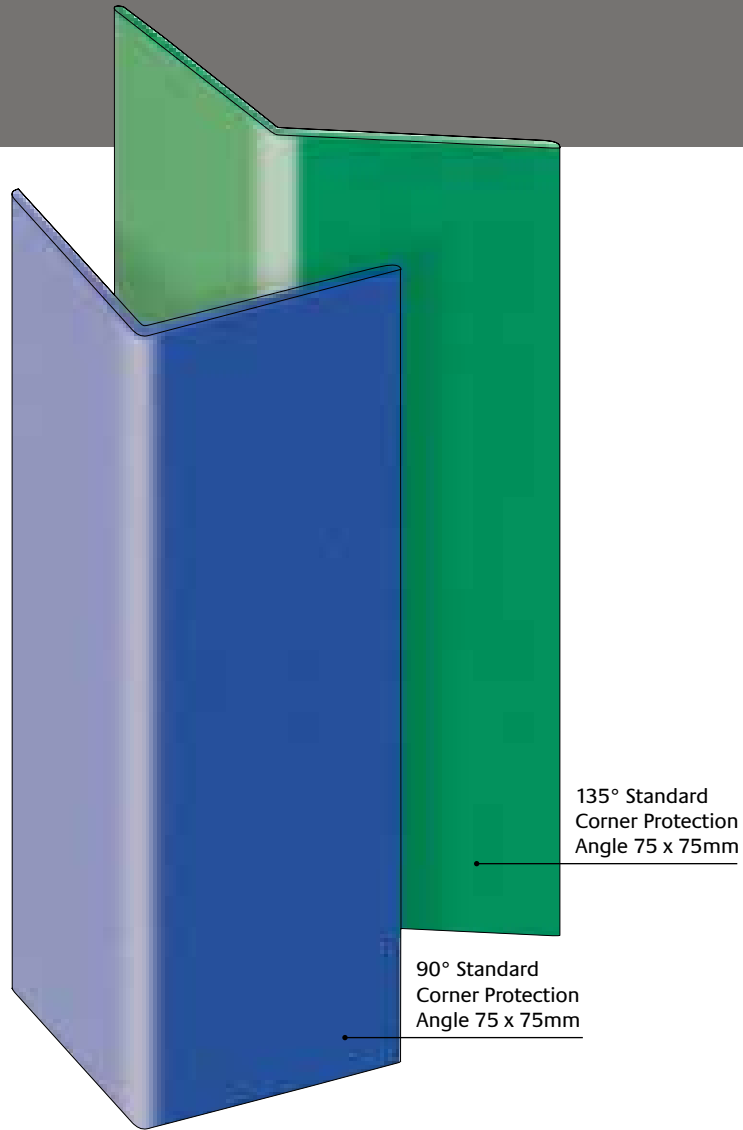
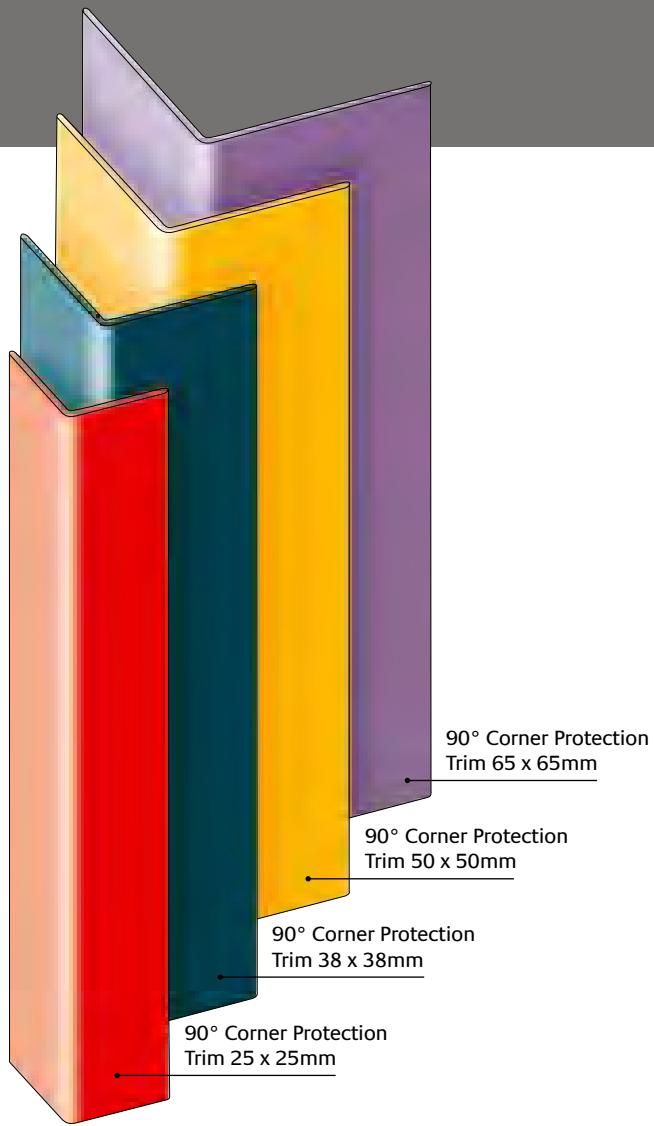

## Installation

Ensure the wall surface is primed, clean, free of dust and grease, dry and flat. Wallpaper, where fitted, should be cut back and the wall surface primed to ensure adhesion. (Some wallpapers react and reject adhesive tapes).

We recommend that 75 x 75mm, 65 x 65mm and 50 x 50mm angles be taped on both legs with Yeoman Shield 1mm double sided adhesive tape.

When fixing Corner Protection Angle, peel off the backing paper from leg one and peel back the paper for the first 100mm of leg

two. Locate the angle by guiding into position on leg two to ensure correct placement is achieved, remove the remaining double sided adhesive tape and apply pressure.

38 x 38mm and 25 x 25mm trims need only be taped on one leg using Yeoman Shield 0.27mm or 0.50mm double sided adhesive tape. Position the angle by guiding in on non-adhesive leg to ensure correct placement is achieved and apply pressure.

If the wall surface is unsuitable for fixing with double sided adhesive tape, we recommend Yeoman Shield mastic adhesive. Screws (and plugs) may be used but slightly oversize holes must be drilled in the angle to allow for movement.





# ULTRA CORNER PROTECTION ANGLES

Yeoman Shield Ultra Corner Protection Angles, with their absorption qualities, afford extra resilience to impact where the traditional “plant-on” style may be considered unsuitable.



## Composition

Angles comprise of an extruded Vinylac\* cover and continuous aluminium retainer, with integral rubber spacers and injection moulded stop ends.

## Dimensions

Ultra Angles are extruded in lengths of 3.5m, in both 90° and 135°, with 75 x 75mm legs or 50 x 50mm legs.

N.B. They are normally supplied in 1.15m units but can be cut to any length.

## Colours and Finishes

Standard colours are shown on pages 60 & 61. Special colours are available subject to order quantity or premium.

Ultra Corner Protection Angles have a Stippled finish to help conceal the effects of impact and abrasion.



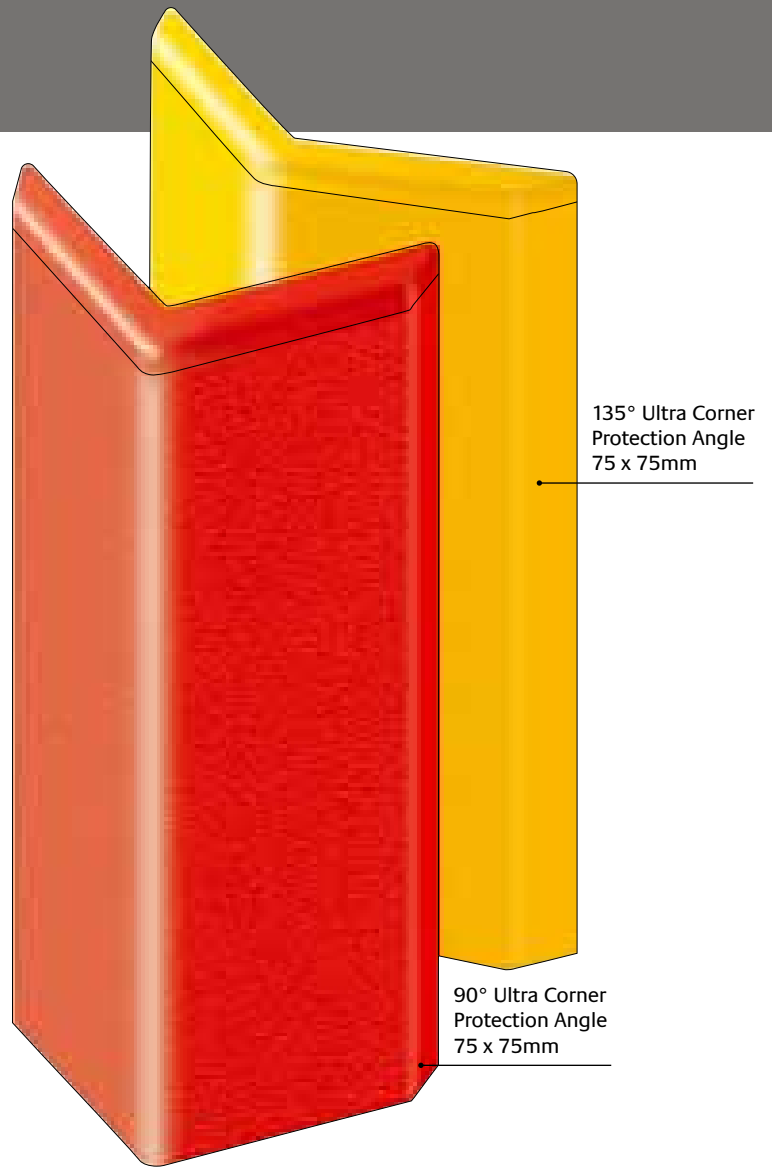
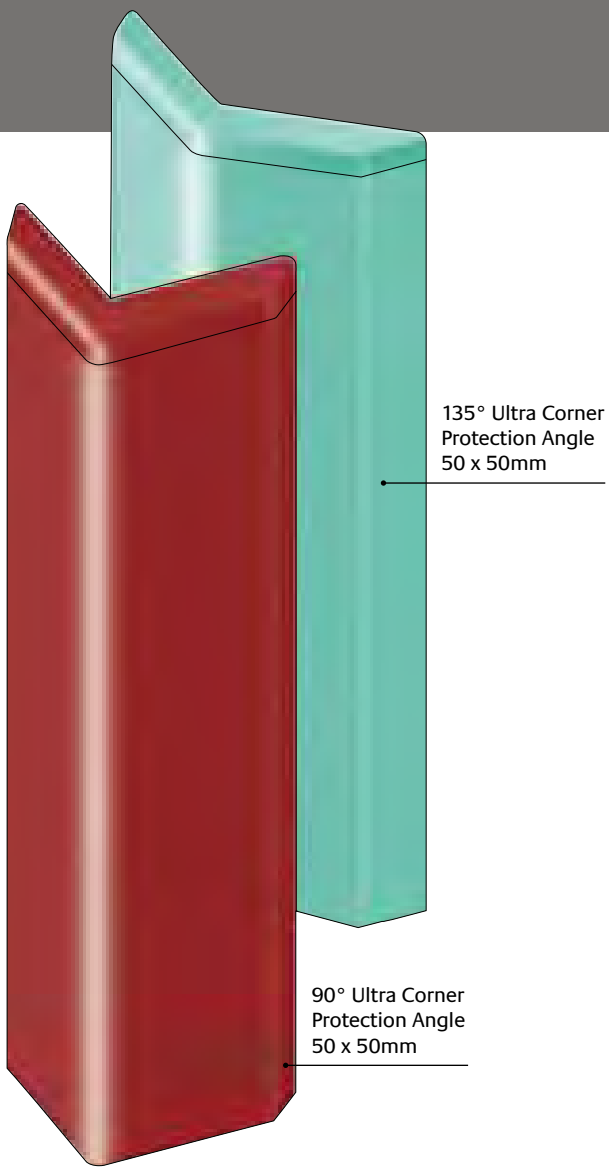

## Installation

Installation instructions applicable to all sizes.

Mark and drill the position of the stop ends and secure using the appropriate fixings as suggested in table. (Stop ends are optional if the angles are being installed from floor to ceiling).

Present the aluminium retainer to the wall and, using the pre-drilled staggered holes, mark, drill and screw fix into position (the retainer is 100mm shorter than the cover, to allow for stop ends).

The Vinylac cover should then be clipped on.

| Wall Structure                                 | Screw                                | Plug                    |
|--|--------------------------------------|-------------------------|
| Plasterboard                                   | Appropriate length 5mm machine screw | 5mm Rubber Rawlnut      |
| Brickwork, Breeze Blockwork, Concrete          | Appropriate length No. 10 woodscrew  | No. 10 Plastic plug     |
| Lightweight Blockwork e.g. Thermalite, Siporex | Appropriate length No. 10 woodscrew  | Fischer S8 Plastic plug |
| Steel  | Self-tapper                          | -                       |

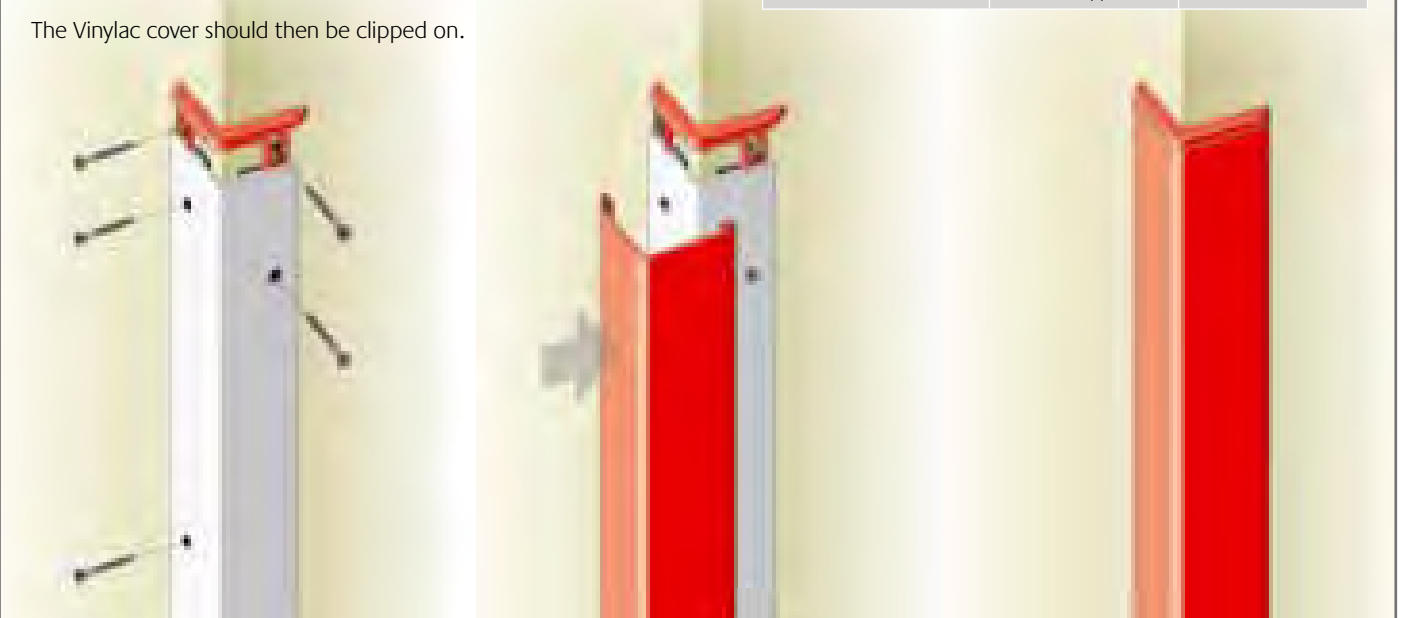

\* Please see information on pages 62 & 63.



# BED HEAD PROTECTORS

Yeoman Shield Bed Head Protectors provide protection to vulnerable wall surfaces and help to prevent damage to essential hospital services.



## Composition

Bed Head Protectors, manufactured using Vinylac\*, can be varied and adapted in many different ways to suit individual needs. They are offered in Protection Rail (200mm deep option shown), Ultra, Premier and Guardian. Stop ends are injection moulded to suit the chosen protector.

## Dimensions

Bed Head Protectors are manufactured in various lengths to suit customer requirements and can be supplied singularly or in pairs.

All protectors may be fixed vertically or horizontally, and either flat back to the wall or on spacer blocks. Standard Cream spacer blocks are 55mm projection but we can also make 'Specials' in either PVCu or metal spacers to give additional stand off.

## Colours and Finishes

Standard colours are shown on pages 60 & 61. Special colours are available subject to order quantity or premium.

The face of Bed Head Protectors has a Stippled finish to help conceal the effects of impact and abrasion.

Spacers are Cream.



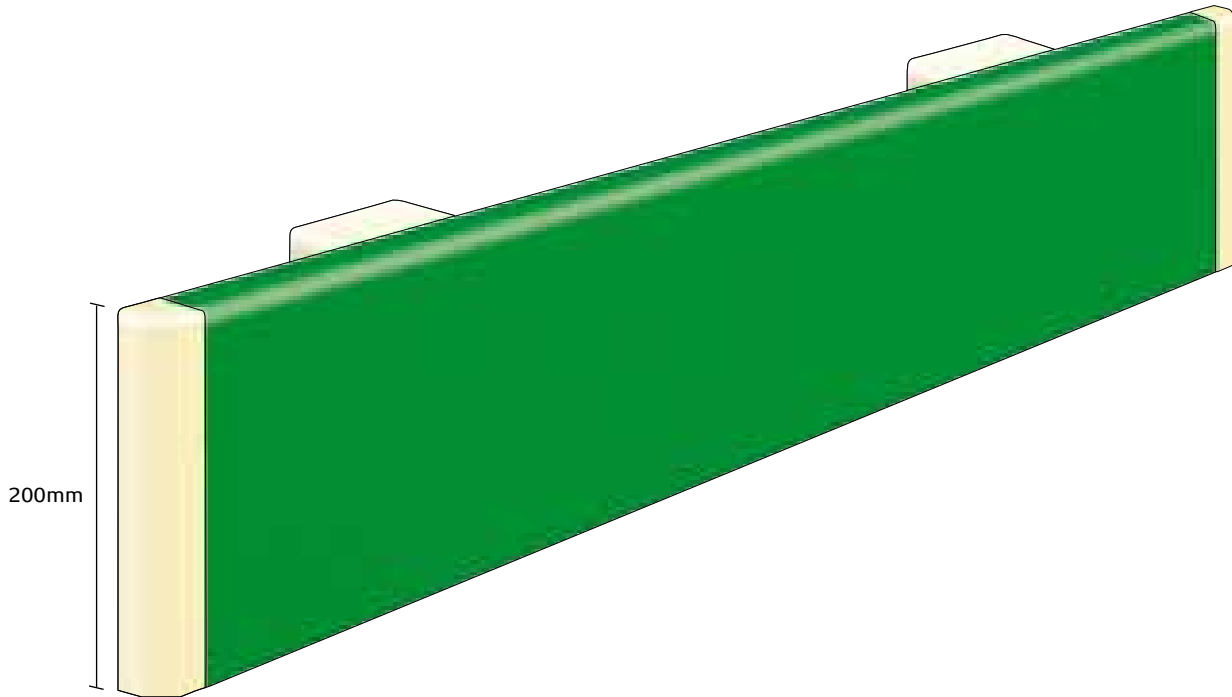

### Installation

Yeoman Shield Bed Head Protectors are usually manufactured and supplied to required type, size and length ready for fixing. They may be fitted flat back to the wall or on standard Cream spacers, as the 200mm example shows, or on special length PVCu or metal spacers to give additional stand off.

Mark the pre-determined position of the protector/spacer brackets and screw into position, using the appropriate fixings as suggested in table. (When fitting back to wall, screw fix stop ends).

Screw fix the core to the spacer (stand off only), and clip on the Vinylac cover.

Fit the stop ends using the appropriate adhesive (stand off only).

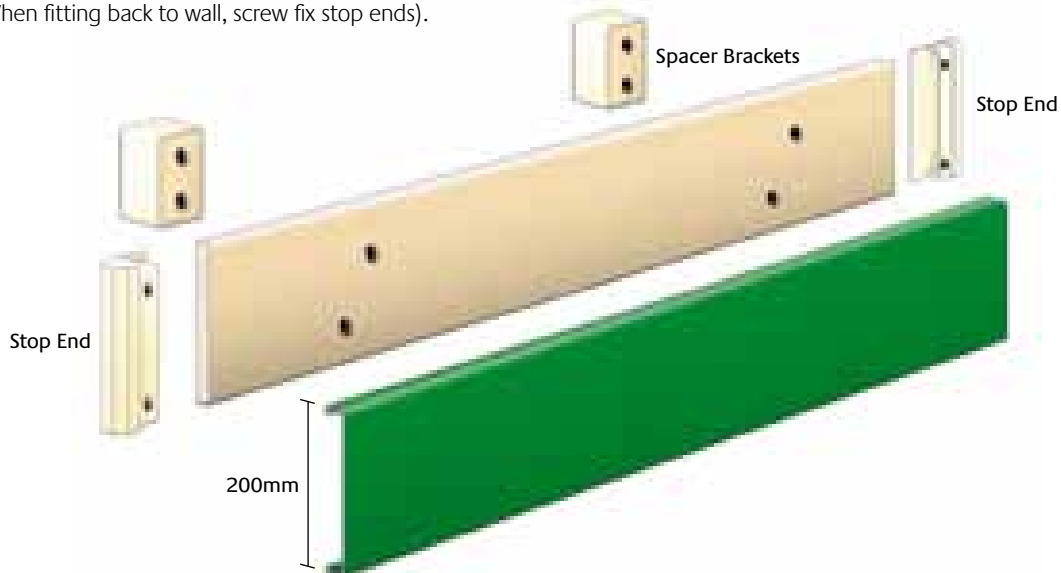

#### Flat Back

| Wall Structure                                 | Screw                                | Plug                    |
|--|--------------------------------------|-------------------------|
| Plasterboard                                   | Appropriate length 5mm machine screw | 5mm Rubber Rawlnut      |
| Brickwork, Breeze Blockwork, Concrete          | Appropriate length No. 10 woodscrew  | No. 10 Plastic plug     |
| Lightweight Blockwork e.g. Thermalite, Siporex | Appropriate length No. 10 woodscrew  | Fischer S8 Plastic plug |
| Steel  | Self-tapper                          | -                       |

#### Stand Off

| Wall Structure                                 | Screw                                | Plug                      |
|--|--------------------------------------|---------------------------|
| Plasterboard                                   | Appropriate length 6mm machine screw | 6mm Rubber Rawlnut        |
| Brickwork, Breeze Blockwork, Concrete          | Appropriate length No. 12 woodscrew  | No. 12 Plastic plug       |
| Lightweight Blockwork e.g. Thermalite, Siporex | Appropriate length No. 12 woodscrew  | Fischer GB10 Plastic plug |
| Steel  | Self-tapper                          | -                         |

\* Please see information on pages 62 & 63.



# SKIRTING

Yeoman Shield Skirting is designed to provide a hygienic, and easily installed and maintained, alternative to traditional timber or tiled skirting.

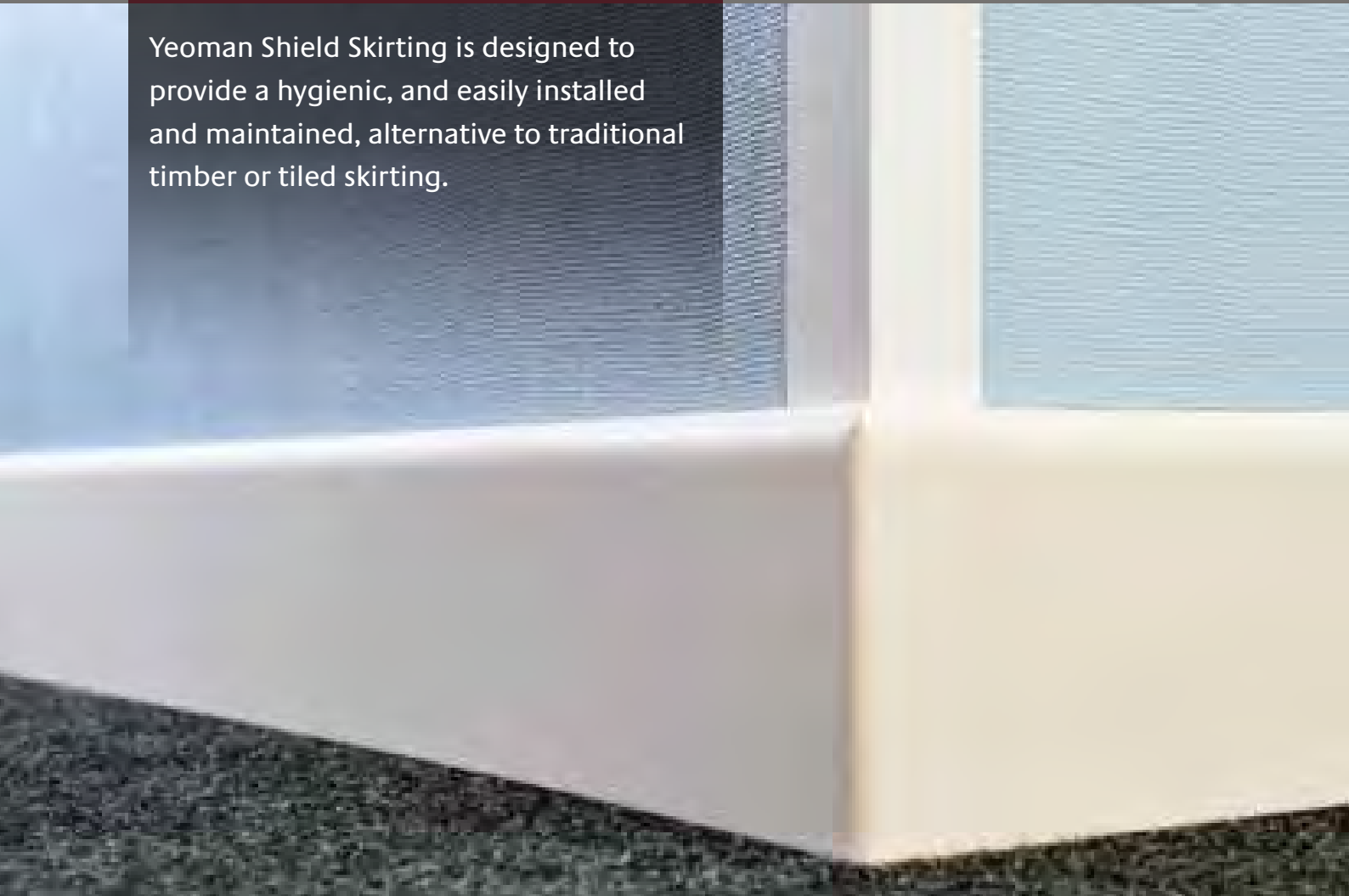

## Composition

The extruded skirtings which are rigid, are manufactured using Vinylac\*.

Corners are fabricated to order.

## Dimensions

The skirtings are extruded in 3.5m lengths, with the 125mm and 100mm deep version having a projection of 10mm and the 110mm deep section, complete with MDF core, projecting 15mm.

External/internal corners have 250 x 250mm legs.

## Colours and Finishes

Standard colours for 125mm & 100mm section are Dark Grey, Brown, Black and White. 110mm section is available in White only.

The skirting has a smooth finish.

Skirting can also be manufactured from Yeoman Shield Protection Strip or Wall and Door Protection Panels (see pages 24-27 & 40-41).

This option is a flat, rigid section available in various thicknesses and widths in a choice of colours and finishes including Stippled, FalmouthEx or HessianEx.



125mm

100mm

110mm

## Installation

Ensure the wall surface is primed, clean, free of dust and grease, dry and flat. Where necessary, fix the MDF core to the substrate using the appropriate fixings as suggested in the table.

Position external/internal corners and fix using appropriate Yeoman Shield mastic adhesive.

Measure and cut skirting to length using a fine tooth tenon saw, all ends must be cut square, and again fix with the Yeoman Shield mastic adhesive.

Silicone seal along the top and bottom edges, if required.

| Wall Structure                                 | Screw                                | Plug                    |
|--|--------------------------------------|-------------------------|
| Plasterboard                                   | Appropriate length 5mm machine screw | 5mm Rubber Rawlnut      |
| Brickwork, Breeze Blockwork, Concrete          | Appropriate length No. 10 woodscrew  | No. 10 Plastic plug     |
| Lightweight Blockwork e.g. Thermalite, Siporex | Appropriate length No. 10 woodscrew  | Fischer S8 Plastic plug |
| Steel  | Self-tapper                          | -                       |





# FLOOR MOUNTED BOLLARDS

Yeoman Shield Floor Mounted Bollards are an easily installed method of protecting vulnerable display units and exposed columns from damage by mobile equipment.



## Composition

**Type 1:** Manufactured from mild steel plate/tube, welded, shot blasted then epoxy coated. The rotating PVCu sleeve is manufactured using Vinylac\*.

**Type 2:** Manufactured from mild steel plate/tube, welded, shot blasted then chromed.

**Type 2a:** Manufactured from stainless steel plate/tube, welded then polished.

**Types 3, 4 and 5:** Manufactured from mild steel plate, welded then chromed, primed or semi-gloss painted.

Base cover plates are available for Types 1, 2 and 2a, and are available in powder coated mild steel, chrome finish or polished stainless steel.

## Dimensions

Standard protectors are 600mm high.

Other sizes and designs are available to order.

## Colours and Finishes

Standard finishes for each type are as mentioned above.

Vinylac\* sleeves, which are smooth, are available for Type 1 in Red, Brown, Black, Dark Grey, Cream, Mid Grey, Buff or Green. Other colours are available subject to order quantity or premium.

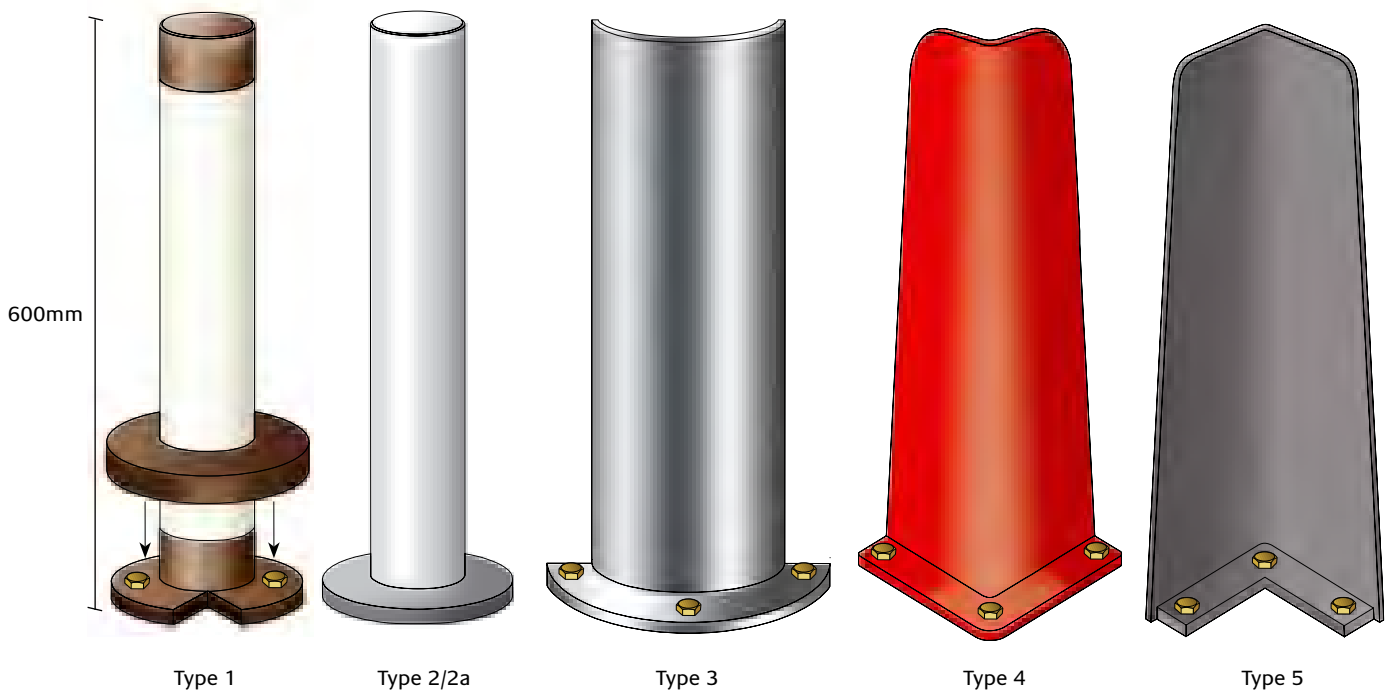

## Specials

Alternative types of Floor Mounted Bollards can be made to your specific requirements. Please contact our Sales Office for further information.

## Installation

Place the protector into position (the 'V' in the base plates on Types 1, 2 and 2a should line up with the corner of the frame or cabinet). Types 3, 4 and 5 should be positioned as close to the frame or cabinet as possible allowing room to ensure a secure fix.

Mark for the bolt holes and drill, using the correct length bit, to ensure an adequate fix through any screed into the concrete.

Fix the protector into position using the appropriate fixing bolts.

N.B. An optional base cover plate is available for types 1, 2 and 2a as shown above.





# DOOR PROTECTION PANELS & PLATES

Yeoman Shield Door Protection Panels and Plates provide much needed protection to vulnerable door surfaces from damage caused by vehicular and pedestrian traffic.

Panels can be cut and shaped in many different ways.



## Composition

Panels and plates are manufactured in sheet form using extruded Vinylac\*, with the fixing option of double sided tape.

## Dimensions

Standard sheets are 2.500m x 1.250m and held in stock in both 2.0mm and 2.5mm thickness.

Panels are workshop cut to suit customer requirements, however full sheets may be supplied if required.

## Colours and Finishes

Standard colours are shown on pages 60 & 61. Special colours are available subject to order quantity or premium.

Door Protection Panels are available in two standard finishes to help conceal the effects of impact and abrasion.

FalmouthEx is a light relief pattern, usually supplied 2.0mm thick, whereas HessianEx, 2.5mm thick, is a more decorative finish.

All panels are supplied with chamfered edges to ensure a smooth, safe edge is attained once fitted and to avoid any ledges.

## Special Information

Panels can be cut and shaped in many different ways to meet individual requirements and offer greater design capabilities (see pages 28 & 29).

Cutting panels to size often leaves us with stock residue material. It may be possible to meet your requirements for Push/Mid/Kick and D Plates from such residue, at reduced cost.







## Installation

Ensure the door surface is primed, clean, free of dust and grease, dry and flat.

When fitting Door Protection Panels and Plates, we recommend using Yeoman Shield 0.27mm or 0.50mm double sided adhesive tape. However, if the quality of the door surface is poor, a 1mm tape may be more appropriate.

Any cut outs in the panels for locks, handles, glazing apertures, air vent grills, etc. should be carried out prior to applying double sided adhesive tape. If the panel is supplied with the tape separate, it should be applied at approximately 3mm from each outside edge of the panel and around cut outs, and then at maximum 300mm centres.

Remove door furniture where necessary. Peel off the backing paper, place the panel in position and apply pressure to ensure full contact.

Re-fix door furniture where necessary.

If the door surface is unsuitable for fixing with double sided adhesive tape, we recommend Yeoman Shield mastic adhesive. Screws may be used, but slightly oversize holes must be drilled in the panel to allow for movement.





# DOOR CLIPPING LATH

The Yeoman Shield Door Clapping Lath conceals the gap where double doors meet and is of particular benefit for X-Ray and Laser Room doors.

This is a toughened, durable product protecting a vulnerable part of the door.



## Composition

The Clapping Lath is manufactured using Vinylac\*, the same material used to produce Yeoman Shield Wall & Door Protection Panels.

The inner core is made from a toughened PVCu material, and comes complete with a lead strip.

## Dimensions

Clapping Laths are also made to your required size. We recommend 15 x 65 x 2100mm high.

Standard thickness for the outer cover is either 2.0mm or 2.5mm, which is formed around an 11.0mm inner core.



## Colours and Finishes

Standard colours are shown on pages 60 & 61. Special colours are available subject to order quantity or premium.

Clapping Lath is available in two standard finishes to help conceal the effects of impact and abrasion.

FalmouthEx is a light relief pattern, usually supplied 2.0mm thick, whereas HessianEx, 2.5mm thick, is a more decorative finish.

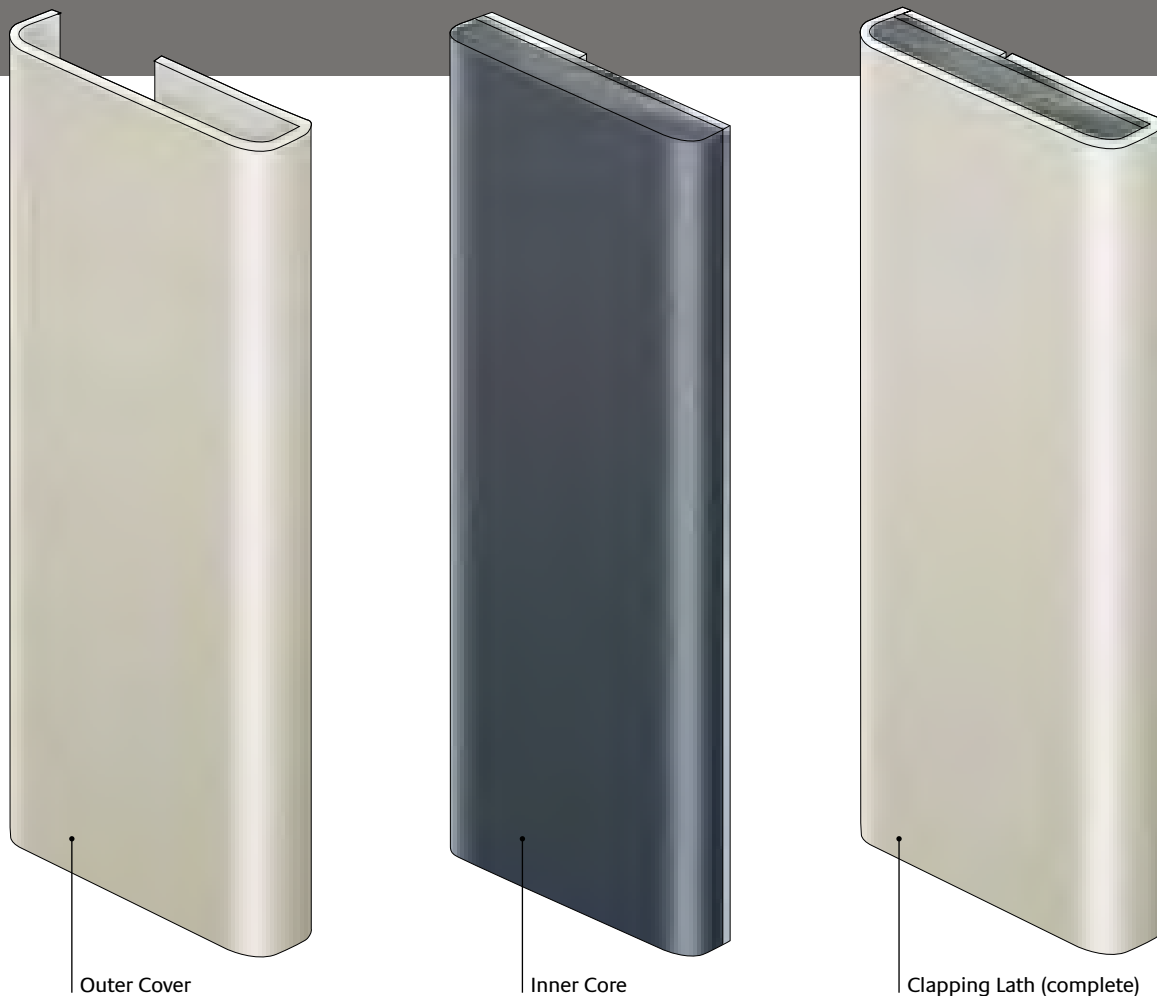

## Installation

Position the lead lined inner core of the Clapping Lath (supplied complete with PVC packer) to the appropriate leading edge of the double door (determined by the direction of opening of the door), ensuring that the drilled holes are away from the edge of the door lipping where it meets the door core, and mark for drilling at 300mm centres.

Once drilled and countersunk, use screws to secure this to the door face.

Apply a thin bead of Yeoman Shield silicone mastic along the length of the inner core.

Position the outer cover of the lath over the leading edge and snap into place. Ensure it is flush with the top and bottom of the inner core.

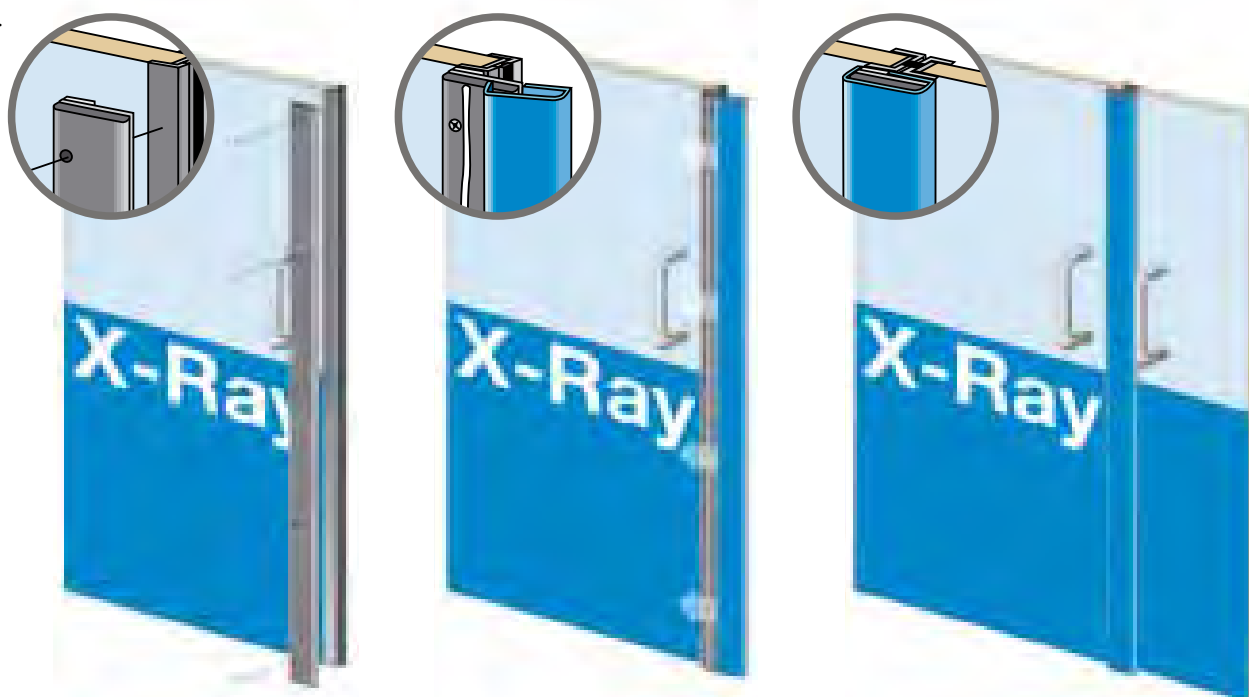



# DOOR EDGE PROTECTORS <sup>®</sup>

Yeoman Shield Door Edge Protectors <sup>®</sup> are designed to reduce damage and expensive maintenance costs to door edges. They can give existing damaged doors a new lease of life.

Door Edge Protectors may be fitted to new or existing fire doors, on the leading and hinged edges, without affecting the door's fire integrity.



## Composition

Door Edge Protectors are manufactured using Vinylac\*, the same material used to produce Yeoman Shield Wall & Door Protection Panels. They have a 9mm thick toughened PVCu inner core and a fire seal insert.

## Dimensions

As the door thickness determines the size, Door Edge Protectors are manufactured to order. We recommend an overlap of 50mm. Standard thickness is 2.0mm, although 2.5mm may also be used.

Door Edge Protectors may be formed to suit radius or square edge doors and double swing corridor doors in various door thickness, with variable overlaps.

They may be fixed to half hour and one hour fire doors by incorporating the appropriate fire, or fire and smoke seals.

N.B. They may also be fitted without seals to non fire doors, where protection or aesthetics is the only consideration.

## Colours and Finishes

Standard colours are shown on pages 60 & 61. Special colours are available subject to order quantity or premium.

Door Edge Protectors are available in two standard finishes to help conceal the effects of impact and abrasion.

FalmouthEx is a light relief pattern, usually supplied 2.0mm thick, whereas HessianEx, 2.5mm thick, is a more decorative finish.

All Door Edge Protectors are supplied with chamfered edges to ensure a smooth, safe edge is attained once fitted and to avoid any ledges.

## Special Information

See page 62 for information on <sup>®</sup> Patent application, fire and smoke tests. Full fire test details are available on request to our Sales Office.

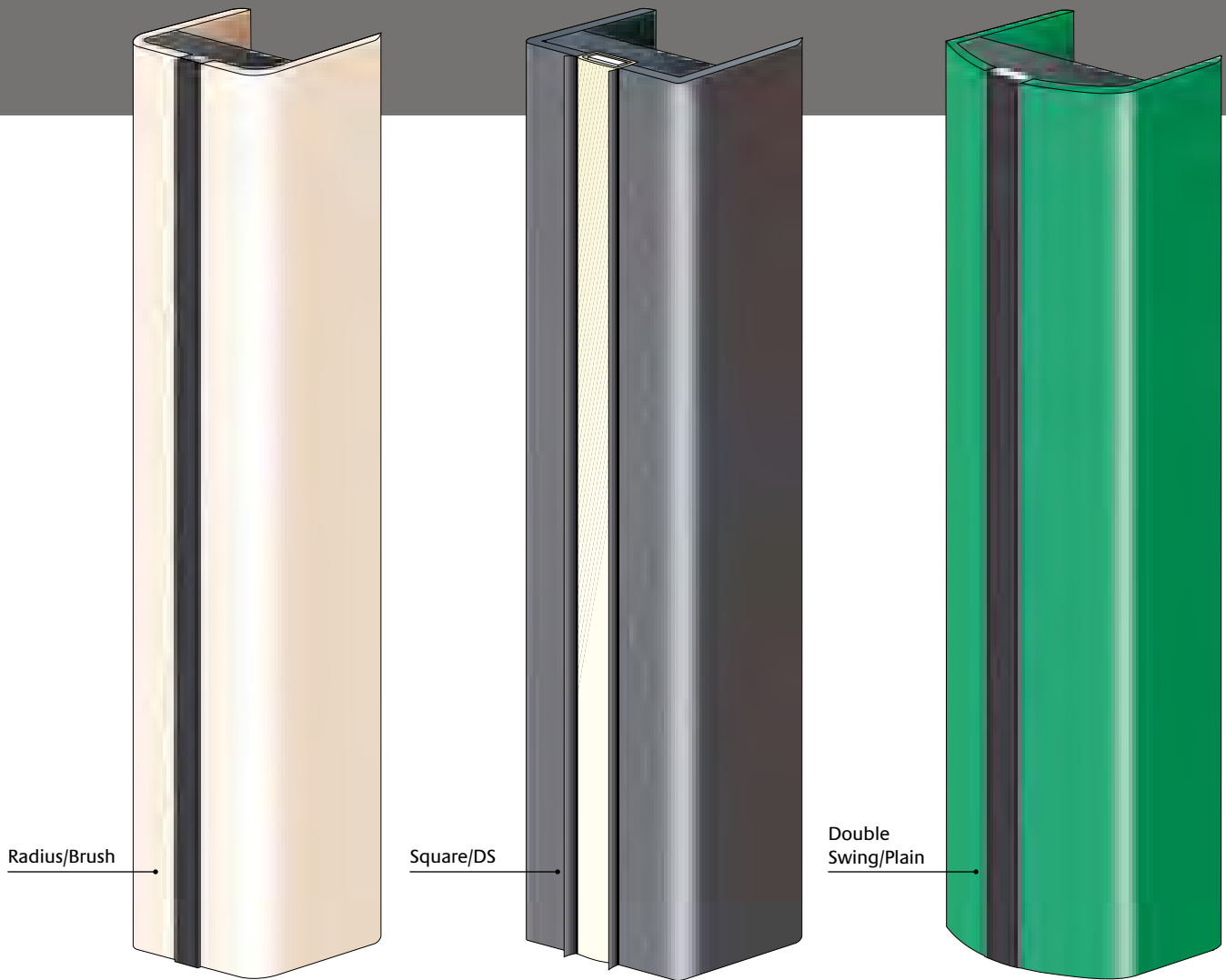

## Installation

Remove door and detach obstructive door furniture.

Reduce width of door to accommodate addition of Yeoman Shield Door Edge Protector.

Cut new protector to length, present to door and mark cut outs for door locks, hinges etc. Cut or rout as necessary. Using countersunk screws, secure the protector into place through the rebated groove.

Remove backing tape from intumescent strip and insert.

When completed, re-hang the door. Where relevant, fit new Yeoman Shield Door Protection Panels, Kick Plates, Push Plates, Finger Plates, etc. and refit door furniture.





# DOOR FRAME & ARCHITRAVE PROTECTORS

Yeoman Shield Frame & Architrave Protectors are either extruded or post-formed to fit new or existing door frames.

They are designed to prevent damage and expensive maintenance costs.



## Composition

Door Frame & Architrave Protectors are extruded to set sizes using Vinylac\*.

They can also be post-formed using the same material as Yeoman Shield Wall & Door Protection Panels (see pages 26–27 & 40-41).

MDF/timber inserts are machined to suit the various PVCu profiles.

## Dimensions

Extruded protectors are 2.0mm thick and available from stock in the following sizes:

Architrave: Square/Radius 18 x 50 x 18mm, Radius/Radius 21 x 50 x 21mm, Square/Splayed 18 x 25 x 25 x 15mm, complete with or without MDF inserts.

Stop Lath: Square/Radius 25 x 50 x 25mm, complete with or without Hardwood or Softwood inserts.

## Colours and Finishes

Extruded Protectors are White, with a smooth finish.

Standard colours for post-formed protectors are shown on pages 60 & 61. Special colours are available subject to order quantity or premium.

Formed Protectors are available in two standard finishes to help conceal the effects of impact and abrasion.

FalmouthEx is a light relief pattern, usually supplied 2.0mm thick, whereas HessianEx, 2.5mm thick, is a more decorative finish.



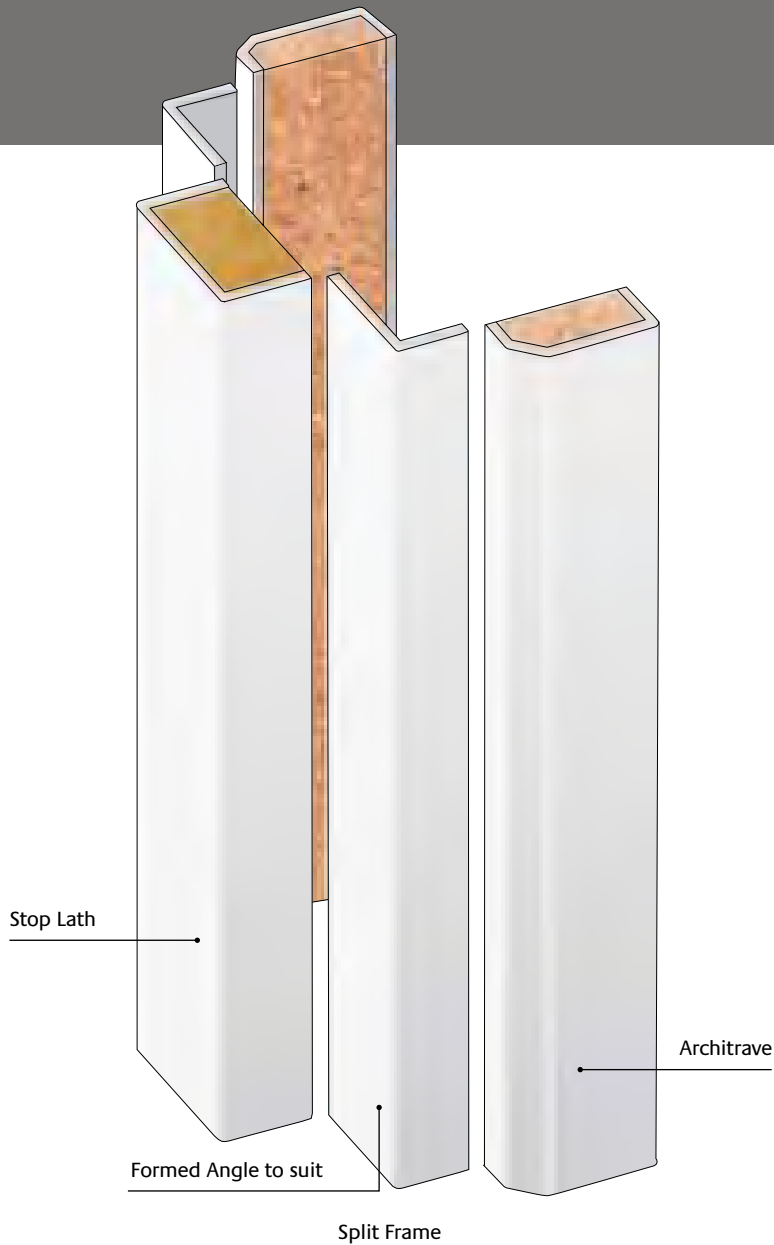

Split Frame

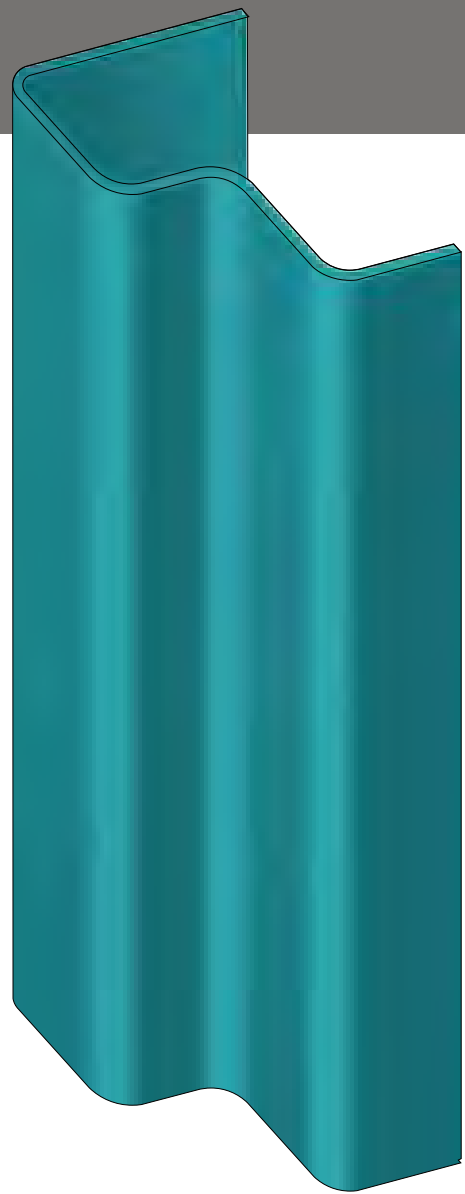

Post-Formed Single Frame

## Installation

Existing Frame and Architraves should be adjusted as necessary, repairing or replacing all damaged sections.

If fitting new MDF/timber inserts, cut to size, including mitres at the jamb/head, and secure into place.

Apply Yeoman Shield mastic adhesive and fit the Frame and Architrave protection into place.





# D-FENDER & C-FENDER

Yeoman Shield D-Fender protects loading bays, storage and manufacturing areas, where heavy duty traffic is common.

Yeoman Shield C-Fender is designed to give protection to barriers. It is mainly used on trolley bays in supermarket car parks.

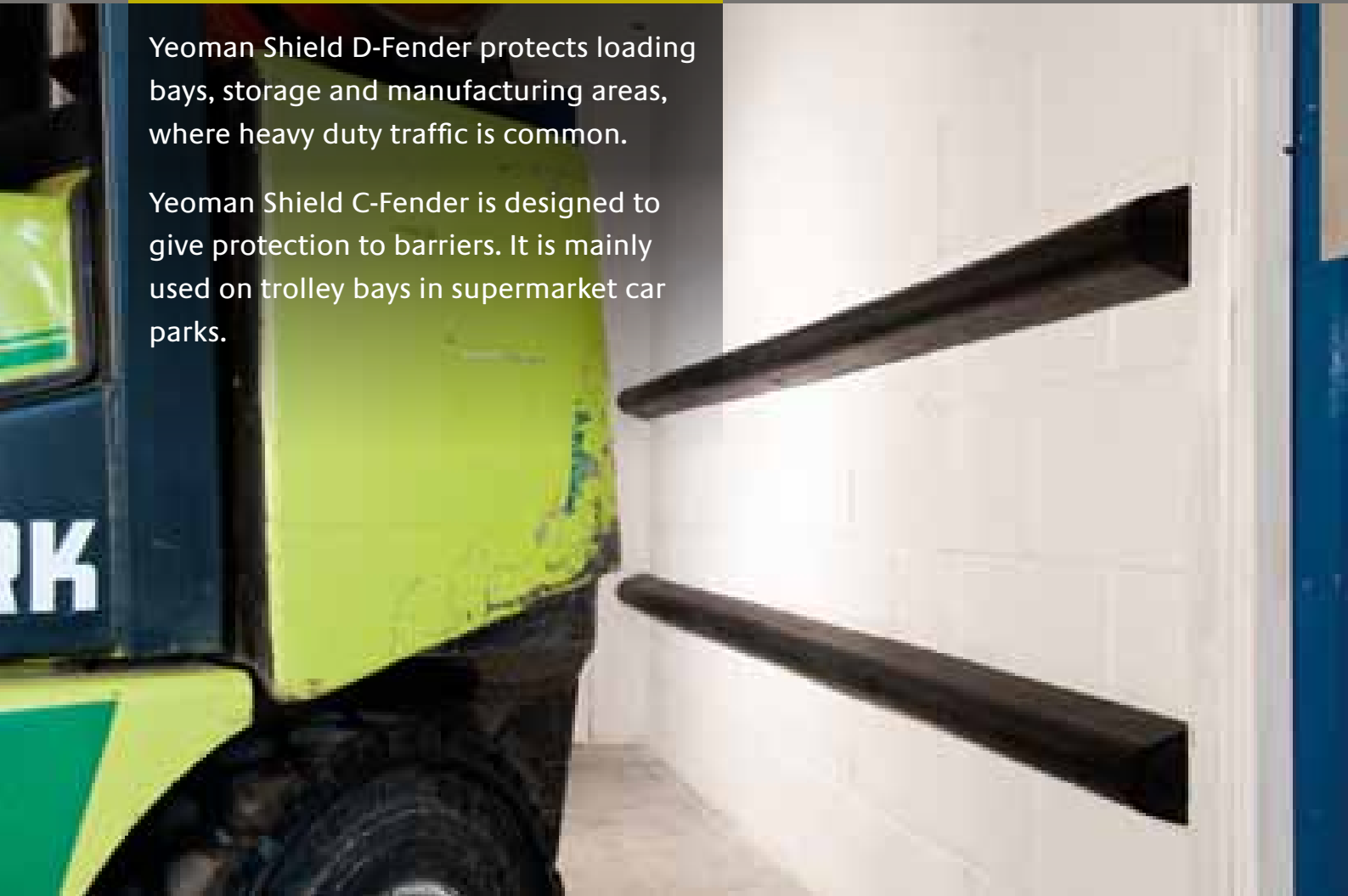

## Composition

D-Fender is extruded SBR/Natural Rubber compound with a galvanised mild steel retaining bar.

Stop ends, internal and external corners and hole bungs are fabricated in the same material.

C-Fender is extruded SBR/Natural Rubber compound. Stop ends, internal and external corners are cut to suit.

A coloured PVCu insert is optional.

## Dimensions

D-Fender is extruded in lengths of 3.5m, has a projection of 90mm, and is 100mm deep. The galvanised mild steel bar is 40 x 5mm.

C-Fender is extruded in lengths of 3.5m to suit tubes of 65-100mm and 45-55mm diameters.

## Colours and Finishes

D-Fender standard colour is Black, although custom matching to limited colours is possible subject to order quantity or premium.

The extrusion has a smooth finish.

C-Fender standard colour is Black, although custom matching to limited colours is possible subject to order quantity or premium.

The extrusion has a smooth finish.

A coloured PVCu insert may be located in the grooved face for visual effect and to conceal fixings.



100mm

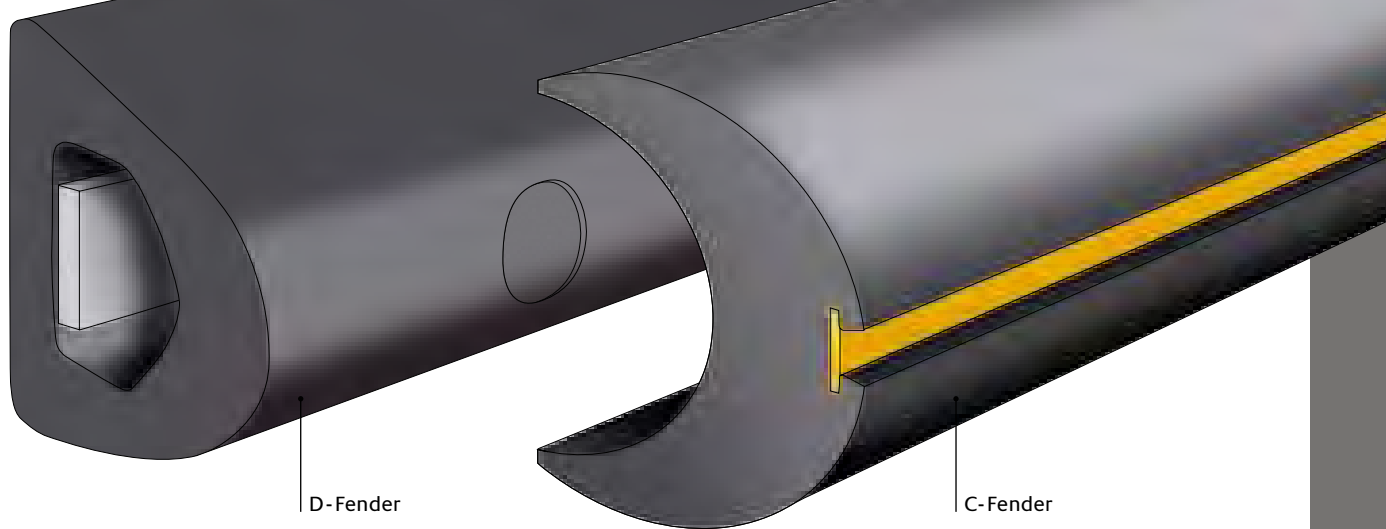

## Installation

D-Fender is supplied cut to length and pre-drilled to suit site sizes. We recommend using Rawlbolts, as the example shows when fixing to brickwork, blockwork, and concrete etc., and coach screws when fixing to timber grounds.

Mark the pre-determined height of the D-Fender on the surface to be protected. Establish the relative position of the galvanised continuous fixing bar and use as a template. (Any external/internal angles supplied should be fixed into position first).

Insert the continuous bar into the D-Fender, aligning it with the fixing holes, and feed through the relevant bolt. Offer the complete section to the wall surface and secure into position. Finally, insert stop ends and hole bungs.

Stop End

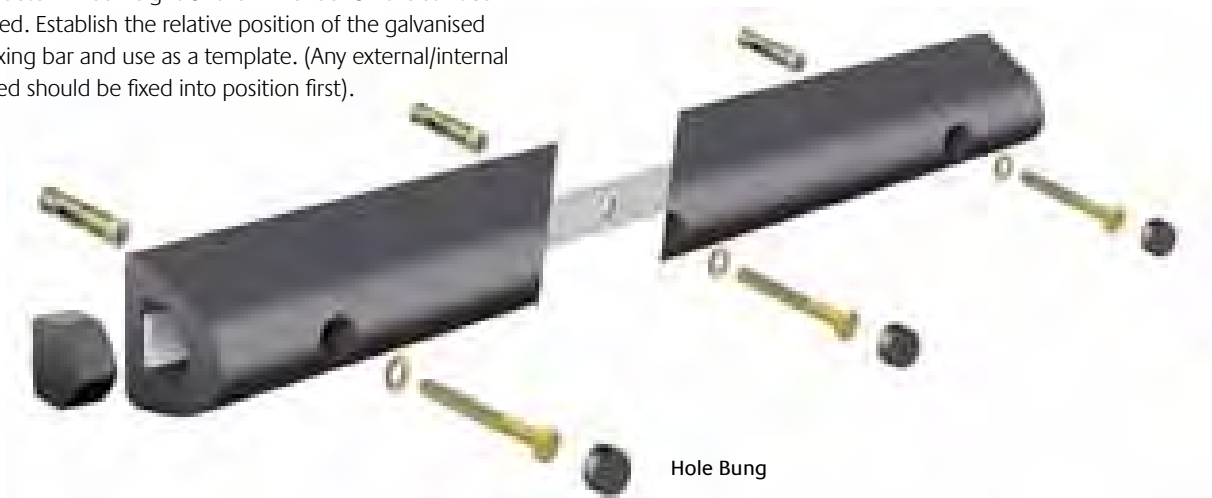

## Installation

Present the C-Fender to the barrier or post and cut to the required length.

Secure the C-Fender using self-tapping screws. In all cases a metal washer must be used with each fixing to ensure it does not pull through the rubber.

If required, we can supply a cut-to-size, coloured plastic feature strip to conceal the fixings.

N.B. This section is flexible and has the ability to bend around radii.





# E-FENDER & MINI E-FENDER

Yeoman Shield E-Fender is designed for use in areas where heavy-duty traffic is common.

Yeoman Shield Mini E-Fender is designed to protect wall surfaces from lightweight vehicular traffic.



## Composition

Both systems are extruded SBR/Natural Rubber compound.

Coloured PVCu inserts are optional.

## Dimensions

E-Fender is extruded in lengths of 3.5m, has a projection of 55mm, and is 225mm deep.

Mini E-Fender is extruded in lengths of 3.5m, has a projection of 18mm, and is 75mm deep.

## Colours and Finishes

The standard colour is Black, although custom matching to limited colours is possible subject to order quantity or premium.

The extrusion has a smooth finish.

A coloured PVCu insert may be located in the grooved face for visual effect and to conceal fixings.

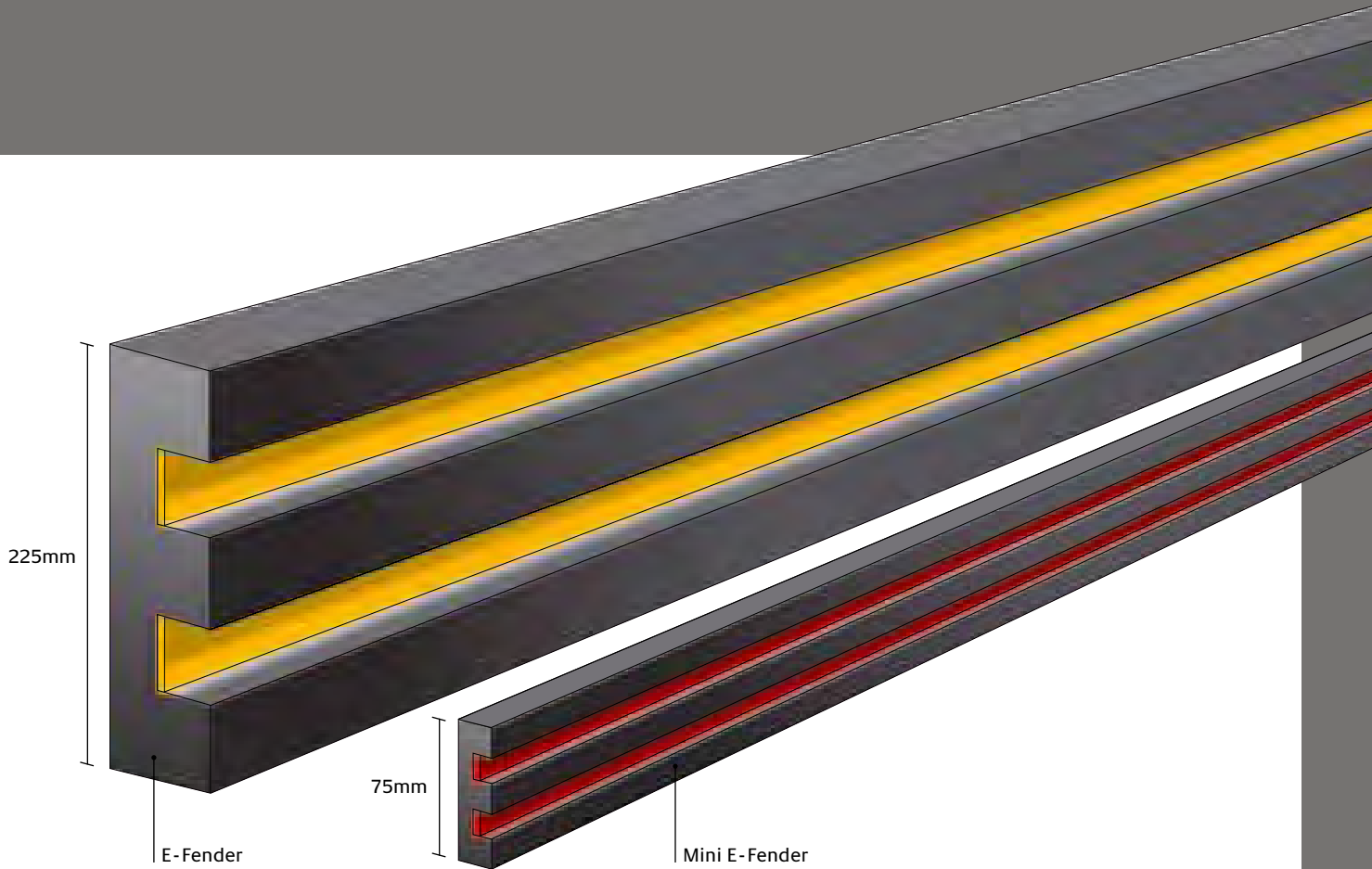

## Installation

Mark the pre-determined height of the fender on the surface to be protected.

For E-Fender, we recommend using Rawlbolts, as the example shows, when fixing to brickwork, blockwork, and concrete etc, and coach bolts when fixing to timber grounds. Mini E-Fender may be fixed with screws and plugs. In all cases a metal washer must be used with each fixing to ensure it does not pull through the rubber.

Where appropriate, measure and cut the fender to the required length using a hacksaw.

Mark and pre-drill through the recesses at maximum 500mm centres and use as a template. Fix fender into position.

If required, we can supply a cut-to-size, coloured plastic feature strip to conceal the fixings.





# DUO-FENDER & MINI DUO-FENDER

Yeoman Shield Duo-Fender affords protection where head-on impact from vehicular traffic is anticipated.

Yeoman Shield Mini Duo-Fender is the smaller alternative to Duo-Fender.

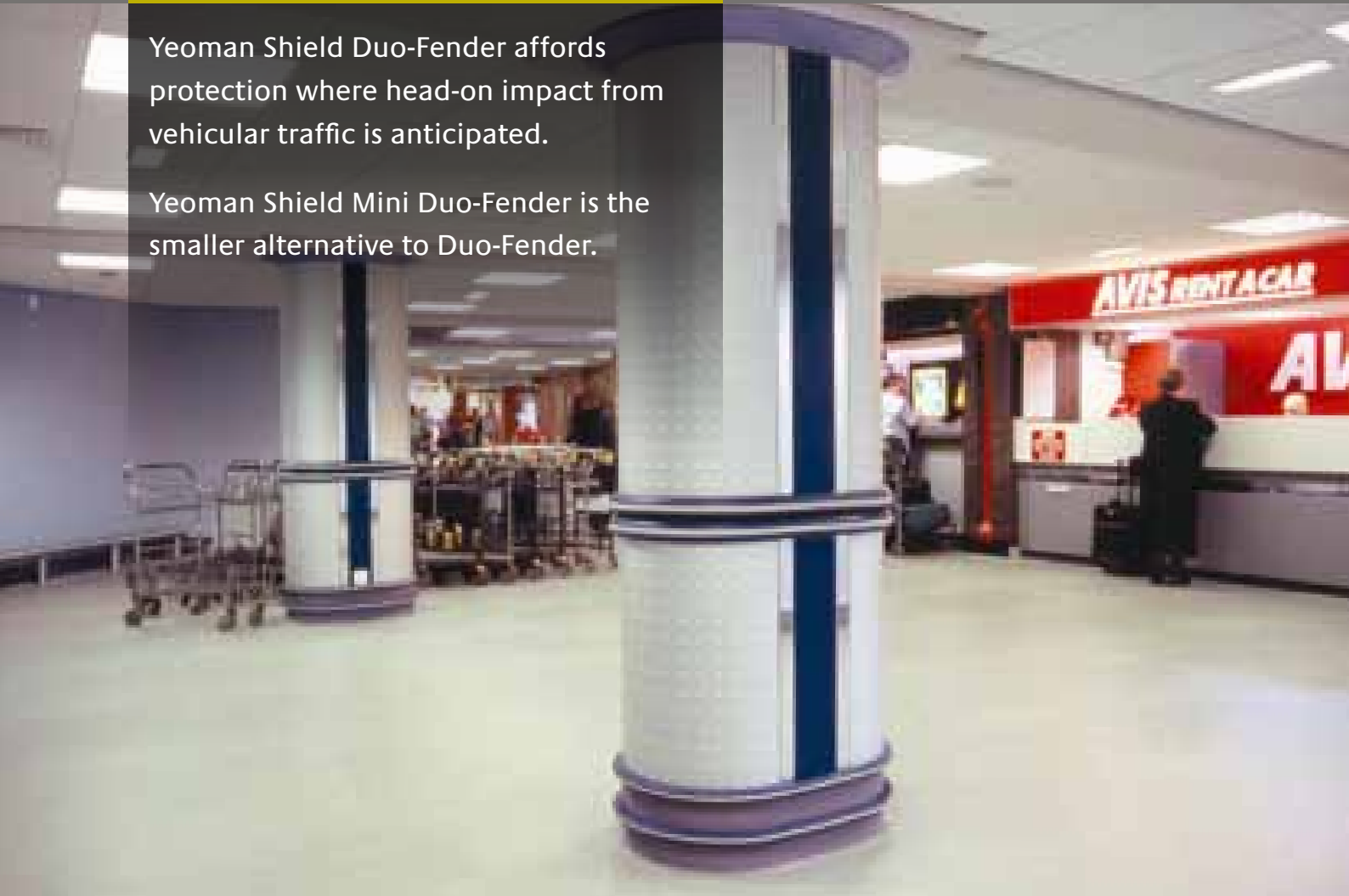

## Composition

Both systems are extruded in EPDM rubber and comprise of two components. External corners and stop ends are injection moulded.

## Dimensions

Duo-Fender and Mini Duo-Fender are extruded in lengths of 3.5m, with a projection of 30mm.

Duo-Fender is 60mm deep and the Mini Duo-Fender is 30mm deep.

## Colours and Finishes

Both these systems are generally available in Black, although custom matching to limited colours is possible subject to order quantity or premium.

The extrusion and injection mouldings have a smooth finish.

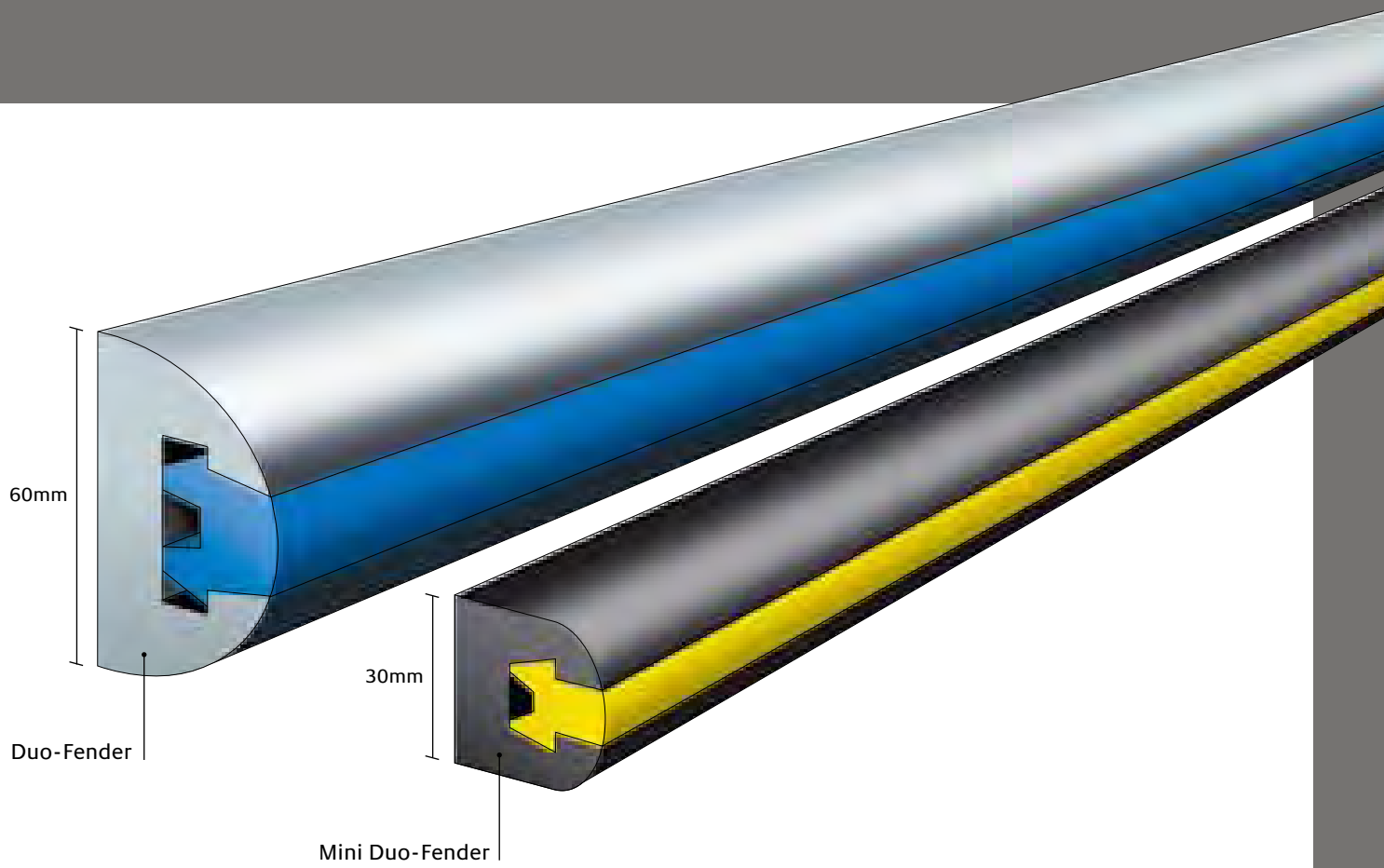

## Installation

Mark the pre-determined height of the Duo or Mini Duo-Fender on the surface to be protected.

Drill and secure the stop ends and external angles using the appropriate fixings as suggested in table.

Where appropriate, measure and cut the fender outer to the required length using a hacksaw.

Pre-drill the outer at maximum 250mm centres and mark, drill and

screw fix into position. In all cases, a metal washer must be used with each fixing to ensure it does not pull through the rubber.

Measure and cut the inner, allowing for stop ends and angles, and insert using an up and down feeding motion.



| Wall Structure                                 | Screw                                | Plug                    |
|--|--------------------------------------|-------------------------|
| Plasterboard                                   | Appropriate length 5mm machine screw | 5mm Rubber Rawlnut      |
| Brickwork, Breeze Blockwork, Concrete          | Appropriate length No. 10 woodscrew  | No. 10 Plastic plug     |
| Lightweight Blockwork e.g. Thermalite, Siporex | Appropriate length No. 10 woodscrew  | Fischer S8 Plastic plug |
| Steel  | Self-tapper                          | -                       |



## MIDI-FENDER

Yeoman Shield Midi-Fender is suitable for use in warehouse areas to prevent impact damage to wall surfaces.

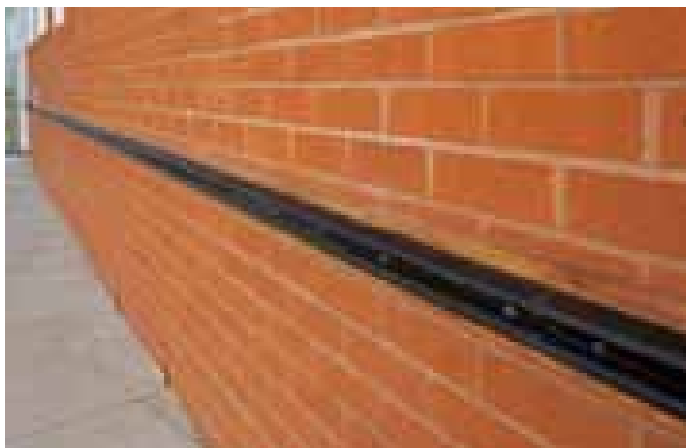
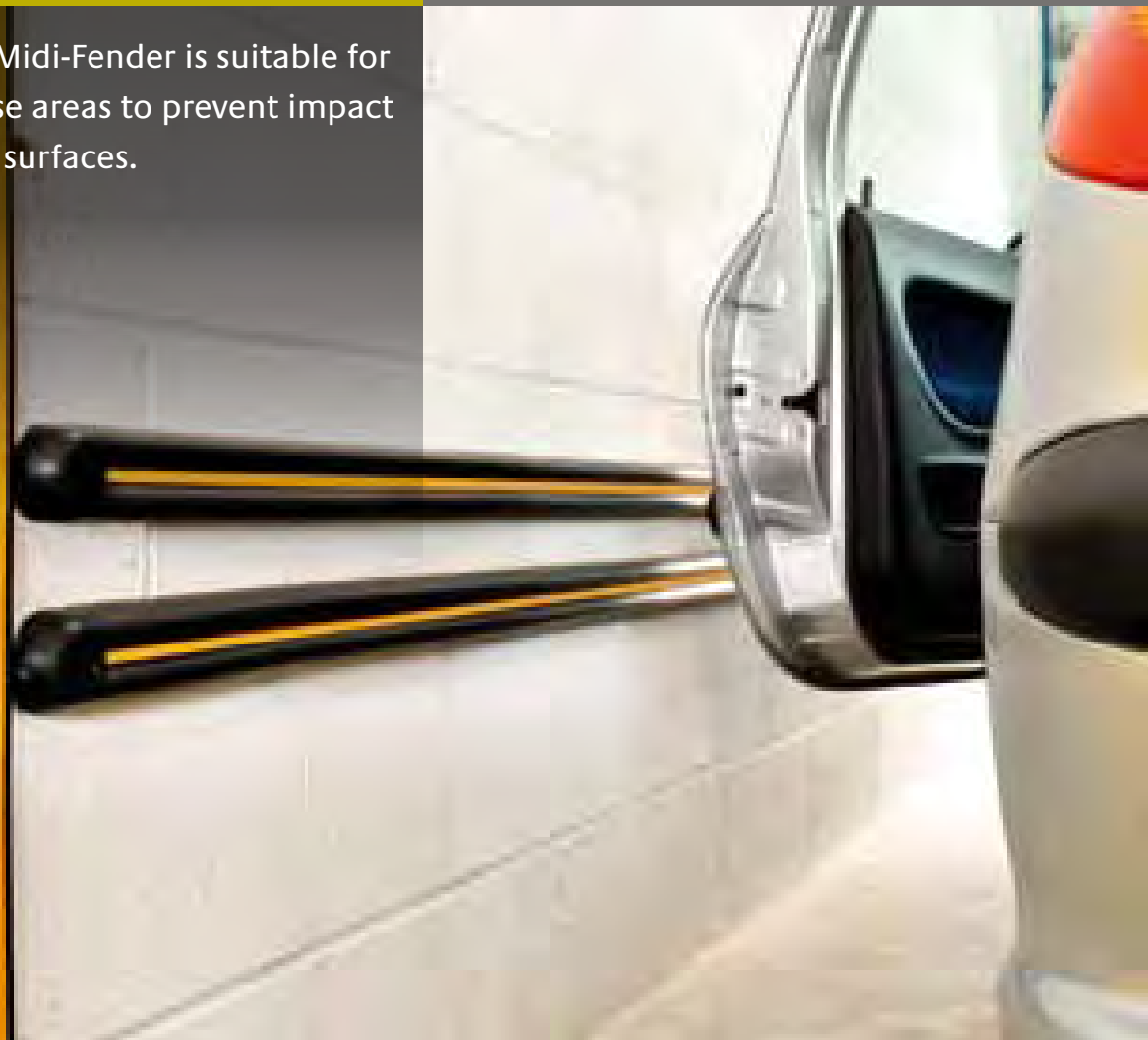

### Composition

The system is extruded EPDM rubber. Stop ends and external corners are injection moulded.

A coloured PVCu insert is optional.

### Dimensions

Midi-Fender is extruded in lengths of 3.5m, has a projection of 35mm, and is 60mm deep.

### Colours and Finishes

The standard colour is Black, although custom matching to limited colours is possible subject to order quantity or premium.

The extrusion has a smooth finish.

A coloured PVCu insert may be located in the grooved face for visual effect and to conceal fixings.

60mm

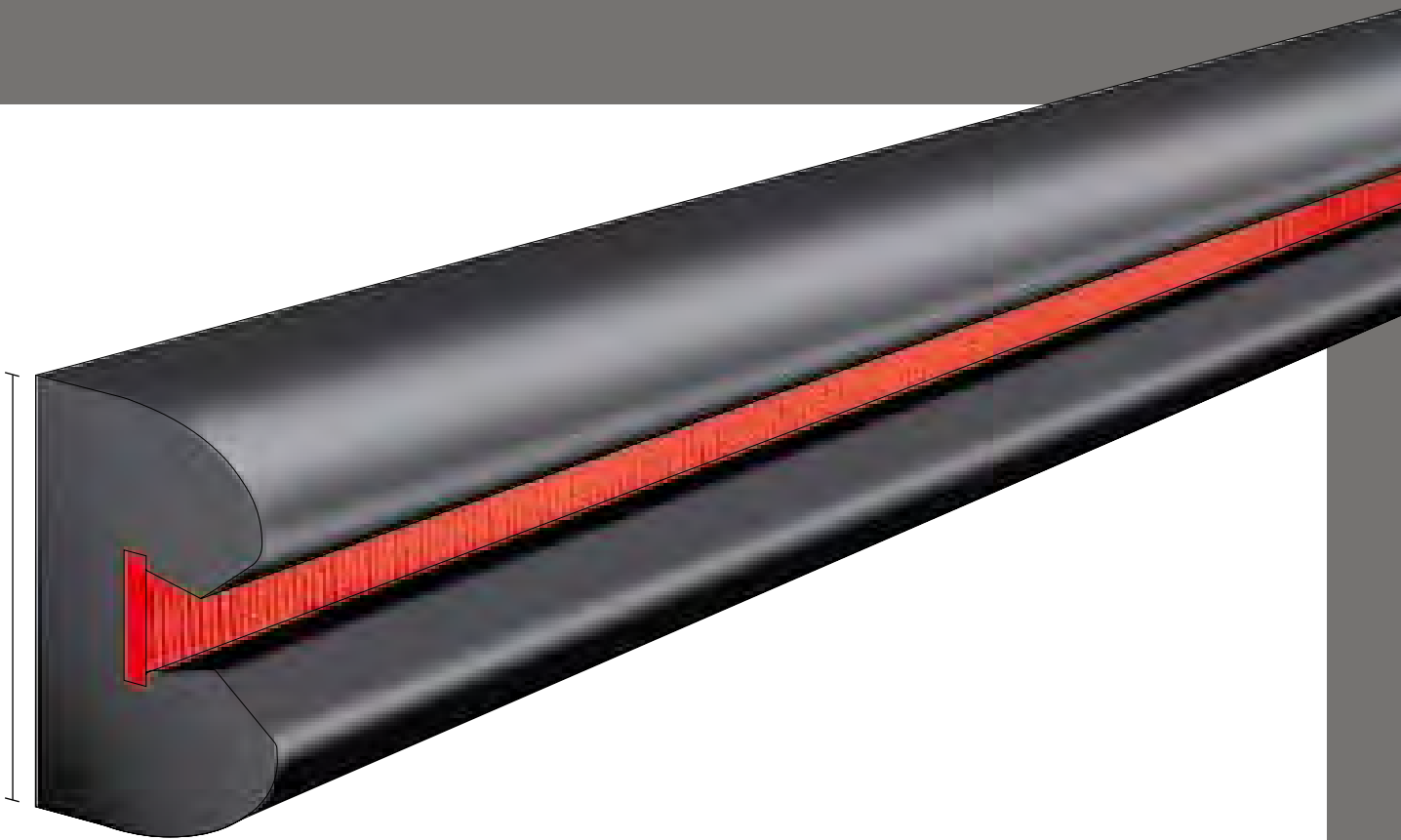

## Installation

Mark the pre-determined height of the Midi-Fender on the surface to be protected.

Drill and secure stop ends and external angles, using the appropriate fixings as suggested in table. In all cases a metal washer must be used with each fixing to ensure that it does not pull through the rubber.

Where appropriate, measure and cut the Midi-Fender to the required length using a hacksaw.

Pre-drill the Midi-Fender at maximum 250mm centres and offer up and use as a template. Fix into position.

If required, we can supply a cut-to-size, coloured plastic feature strip that conceals the fixings.



| Wall Structure                                    | Screw                                   | Plug                       |
|---|---|----------------------------|
| Plasterboard                                      | Appropriate length<br>5mm machine screw | 5mm<br>Rubber Rawlnut      |
| Brickwork, Breeze<br>Blockwork, Concrete          | Appropriate length<br>No. 10 woodscrew  | No. 10<br>Plastic plug     |
| Lightweight Blockwork<br>e.g. Thermalite, Siporex | Appropriate length<br>No. 10 woodscrew  | Fischer S8<br>Plastic plug |
| Steel   | Self-tapper                             | -                          |



# HD100, HD100(H) & MD75, MD75(H)

Yeoman Shield HD100 and MD75 Corner Guards protect vulnerable external angles from damage caused by vehicular traffic.

Yeoman Shield HD100 (H) & MD75 (H) Corner Guards have been developed to provide protection and, at the same time, highlight hazards.



## Composition

The system is extruded Neoprene rubber. The coloured Hazard (H) insert is extruded PVCu.

## Dimensions

Corner guards are extruded in 3.5m lengths, but can be supplied cut to your requirements.

Sections are supplied in the following sizes:

**HD100** - 100 x 100mm, **MD75** - 75 x 75mm

**HD100(H)** - 100 x 100mm, **MD75(H)** - 75 x 75mm.

## Colours and Finishes

The standard colour for HD100 and MD75 is Black, although custom matching to limited colours is possible subject to order quantity or premium.

The extrusion has a smooth finish, but the coloured insert is textured.

The standard body colour for the HD100(H) and MD75(H) is Black. The colour coded PVCu insert can be supplied in any standard colour as shown on pages 60 & 61, with either Stippled, FalmouthEx or HessianEx finish.





## Installation

Where appropriate, measure the Corner Guards and cut to length using a hacksaw.

Providing the corners to be protected are new build or not too badly damaged, then Yeoman Shield mastic adhesive is recommended.

Alternatively, mechanical fixings, as suggested in table, can be used. In all cases a metal washer must be used with each fixing to ensure that it does not pull through the rubber.

Where necessary, fit the PVCu coloured insert into position using Yeoman Shield mastic adhesive.



| Wall Structure                                    | Screw                                   | Plug                       |
|---|---|----------------------------|
| Plasterboard                                      | Appropriate length<br>5mm machine screw | 5mm<br>Rubber Rawlnut      |
| Brickwork, Breeze<br>Blockwork, Concrete          | Appropriate length<br>No. 10 woodscrew  | No. 10<br>Plastic plug     |
| Lightweight Blockwork<br>e.g. Thermalite, Siporex | Appropriate length<br>No. 10 woodscrew  | Fischer S8<br>Plastic plug |
| Steel   | Self-tapper                             | -                          |



# MARKET DIVERSITY



Russells Hall Hospital

Watford General Hospital

Leeds Bradford Airport

Over 40 years experience in the field of wall and door protection has provided us with an immense wealth of knowledge and the experience and product range to meet the varying challenges that are presented to us. Yeoman Shield products are installed in many diverse public buildings throughout the country and overseas. We have established ourselves as a market leader in the field of wall and door protection systems for new build and refurbishment projects and we are also able to meet the requirements of unusual applications that involve awkward or non standard elements.

## Healthcare

**Protecting hospitals, GP surgeries and other buildings used for medical purposes is our forté. We can provide a range of Yeoman Shield products to prevent expensive and unsightly damage occurring to walls, doors, corners and fixtures, whilst protecting precious budgets.**

In order to meet fire regulations, Russells Hall Hospital in Dudley was faced with the substantial expense and inconvenience of replacing over 50 damaged fire doors.

Yeoman Shield came up with a convenient and cost effective means of repairing the existing fire doors, removing the expense of purchasing new doors. The installation of Door Edge Protectors complete with the appropriate fire and smoke seals resulted in considerable savings (see image, top left).

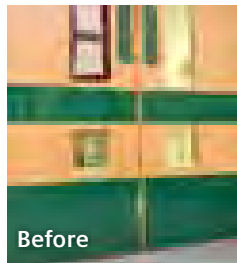

Watford General Hospital required a wall protection system that could be applied to unusually shaped curved walls to maintain the pristine appearance of the Acute Admissions Unit.

Yeoman Shield was able to fit 200mm Protection Strip to the curved walls. The textured finish of the product minimises the appearance of scratches and abrasions caused by the ongoing movement of staff, visitors and wheeled equipment and trolleys.



Glasgow Royal Infirmary presented an unusual project with a requirement for protection of floor to ceiling glass partition walls. It was imperative, from a health and safety perspective, that the glass could not be broken by passing traffic.

Yeoman Shield came up with an ideal solution in the form of 125mm Combined Handrail/Protection Rail which was fitted at mid height to the vertical metal framework and butted up to the corners. The system also acts as an effective handrail to support infirm or elderly patients and visitors.



Deflecting and concealing wall and door damage from passing traffic is a constant battle in busy public buildings. In order to maintain a smart appearance and minimise future maintenance costs, the Harvey Ward at Kent and Canterbury Hospital underwent a programme of refurbishment which included a requirement for effective surface protection on curved walls.

This gave Yeoman Shield the opportunity to demonstrate the flexibility and possibilities of their products. The solution came in the form of Wall Protection Panels that were fitted to follow the curves of the walls resulting in the appearance of a flawless and professional interior.



## Corporate

**Busy buildings such as offices, banks, airports, bus stations and hotels are all vulnerable to damage caused by high pedestrian footfall and wheeled equipment, such as suitcases and trolleys used for luggage, housekeeping, laundry and post rooms.**

When Leeds Bradford Airport refurbished areas of the ground and first floor, it was imperative that oval shaped internal columns in the busy arrivals hall were protected with a robust system to combat damage from heavy suitcases, luggage trolleys and passengers.





Reckitt Benckiser

Woking Leisure Centre

New Bridge School

Yeoman Shield overcame the complication of providing a system that could be applied to oval columns by fitting heavy duty Duo-Fenders and Mini Duo-Fenders at low and mid level. The extruded rubber system affords protection from head on impact and the colour was custom matched to colour co-ordinate with the interior décor of the building.

Many busy public buildings such as the reception area of Dublin Bus' Harristown Garage depot, have high volumes of pedestrian traffic and require a system that will keep the total surface of the wall protected.



Yeoman Shield Wall Protection Panels were fitted above skirting to mid height as a solution to damage that occurs at varying heights. The textured panels work efficiently to disguise scuffs and abrasions.

## Retail

Yeoman Shield has a specialist range of wall and door protection products specifically designed to meet the requirements of shop fitters and retailers.

Our rails provide maximum performance for wall protection from supermarket trolleys and larger indoor vehicular traffic and are also ideal for installation in other areas vulnerable to damage, such as supermarket check-outs and customer service desks.

The busy pharmaceutical division of Reckitt Benckiser was looking for a cure for extensive damage to large doors fitted throughout the plant caused by a combination of heavy pedestrian traffic, pulled/pushed trolleys and small motorised trucks.

Yeoman Shield concealed the unsightly dents and scratches by fully cladding each door with Door Protection Panels and Door Edge Protectors (see image, top left). The cost effective alternative removed the huge expense and inconvenience of replacing all the damaged doors, whilst reducing future damage and expensive maintenance costs.



## Leisure

Yeoman Shield's range of Protection Rails and Wall and Door Protection Panels are the ideal remedy to stop damage at varying heights, which is commonly found in busy leisure centres.

Woking Leisure Centre required protection to disguise wall damage that had occurred from visitors using the centre's wide range of sports facilities. The centre also needed to satisfy health and safety requirements, which specify that walls in such areas need to be completely smooth.



Yeoman Shield met the brief by supplying bespoke Wall Protection Panels in a FalmouthEx finish which were factory cut to suit the specific wall size. The panels provide a good backdrop and clear visibility in the 10 badminton courts and the light relief pattern conceals impact and abrasion.

## Education

Preserving the fabric of a busy school, college or university is always going to be a challenge - one which Yeoman Shield relishes. The rough and tumble of students moving around buildings from one class to another can quickly cause unsightly damage and lead to corridors and doors losing their pristine appearance.

Using our in-depth experience of the educational market, Yeoman Shield can provide the advice and products needed to protect budgets and the fabric of buildings which often have to withstand a heavy volume of pedestrian traffic.

New Bridge School in Oldham, a purpose built school for children with special needs, required tough DDA compliant wall protection to provide support for visually impaired students and also to prevent damage from wheelchairs and walking aids.

Yeoman Shield Guardian Handrail was fitted with colour contrasting corner angles and stop ends to help denote doorways and changes of direction. Additionally, the rounded grip top of the Guardian Handrail provides support and guidance whilst protecting walls from impact damage.

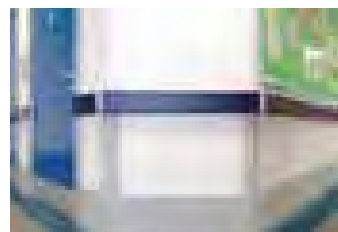



# COLOUR OPTIONS AND FINISH SPECIFICATIONS

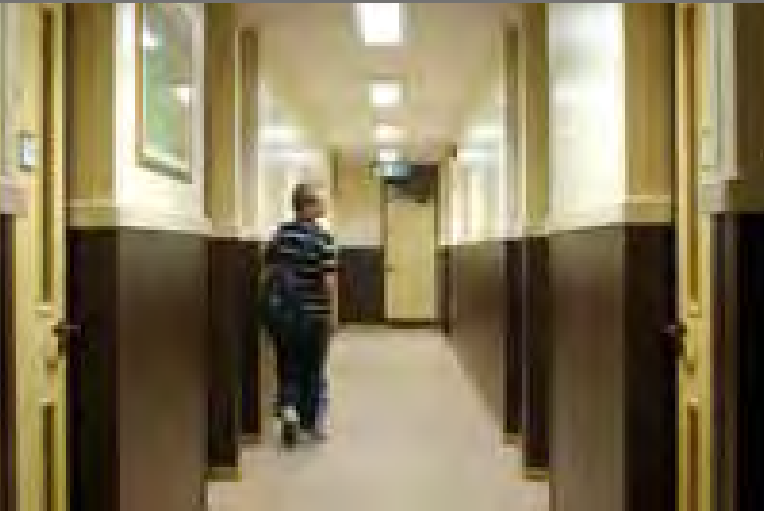

## Standard Colours

We carry stock of all colours and a colour swatch is available from our Sales Office.

Any product where the stock level is low, due to popular demand, can generally be manufactured within 7 days from receipt of your order. However, lead times may be longer for the HessianEx and FalmouthEx sheet.

Products such as Rigi Rail, Flexi Rail, Maxi Rail, Skirting, Door Frame Protection, Floor Mounted Bollards and Corner Trims have a smooth finish and are held in stock in a limited colour range. Please check with our Sales Office.

Generally, Heavy Duty products are only available in Black. However, Mini Duo-Fender and Duo-Fender can be produced in certain colours, both outer and inner, but these will be subject to lead time and additional costs, which will be determined once exact quantity is known. The new HD100(H) & MD75(H) rubber corner angles are extruded in Black and have coloured PVCu inserts from our standard colour range.

## Special Colours

We are able to match your specific colour choice subject to sufficient quantity requirement. Please contact our Sales Office for further details.

## Samples

Samples of all products are available on request from our Sales Office.

## Colour Shades

Colours shown are as accurate as printing processes allow (for a more exact colour match please request a **Yeoman Shield** product sample).

BS 4800 and RAL colour references are given to indicate the nearest colour where possible. Colour matching between products can only be as close as differing manufacturing processes permit.

## Colour Features

Contrasting the colour of the rail with the stop ends and external angles can help the partially sighted, as recommended in the DDA regulations.

## Colour Fastness

















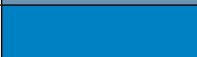

Vinylac products are UV stabilized to reduce colour fading when exposed to direct sunlight.

## Advice

If you have any questions or queries with the details on this colour card, then please do not hesitate to contact our Sales Office where our technical staff will be happy to assist you.

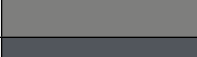
## Distribution

Available direct from the manufacturers in Leeds to anywhere in the country, anytime if necessary, using either our own delivery vehicles or reputable carriers.

| Colour       | RAL/BS No. | Colour Guide  | LRV* | NCS**     |
|--------------|------------|---|------|-----------|
| Red          | BS 04 E 53 |    | 15   | 1580-Y80R |
| Yellow       | BS 08 E 51 |    | 50   | 4050-B    |
| Grapefruit   | BS 10 E 50 |    | 66   | 0570-Y    |
| Pastel Green | RAL 6019   |    | 53   | 1030-G30Y |
| Green        | BS 14 E 53 |    | 19   | 2565-G    |
| Opal Green   | RAL 6004   |    | 8    | 7020-B50G |
| Slate Green  | -          |    | 17   | 6010-G10Y |
| Light Green  | RAL 6027   |    | 39   | 2030-B60G |
| Aqua Blue    | RAL 5018   |    | 17   | 5020-B50G |
| Sky Blue     | -          |    | 61   | 1020-B10G |
| Pigeon Blue  | BS 18 C 35 |    | 42   | 2030-B    |
| Powder Blue  | BS 20 C 33 |    | 54   | 1020-R90B |
| Pastel Blue  | RAL 5024   |   | 25   | 4030-B    |
| Regatta Blue | BS 18 E 53 |  | 16   | 4050-B    |
| Dark Blue    | RAL 5002   |  | 8    | 4055-R70B |
| Steel Blue   | RAL 5011   |  | 6    | 7020-R80B |
| Pink Rose    | BS 04 E 49 |  | 73   | 0510-R    |
| Lilac        | RAL 4001   |  | 18   | 4040-R40B |
| Blush        | -          |  | 17   | 5020-R    |
| Bordeaux     | RAL 4004   |  | 6    | 7020-R10B |
| Brown        | BS 08 B 29 |  | 8    | 8502-R    |
| Burgundy     | RAL 3003   |  | 8    | 3560-Y90R |
| Terracotta   | -          |  | 9    | 4050-Y80R |
| Orange       | -          |  | 16   | 3560-Y70R |
| Buff         | RAL 1001   |  | 38   | 3020-Y30R |
| Avocado      | -          |  | 29   | 4010-G90Y |
| Mushroom     | BS 08 B 17 |  | 51   | 2010-Y20R |
| Cream        | BS 10 B 15 |  | 79   | 0502-Y    |
| White        | RAL 9016   |  | 86   | 0500-N    |
| Light Grey   | BS 00 A 01 |  | 58   | 1502-Y50R |
| Mid Grey     | BS 00 A 05 |  | 39   | 3500-N    |
| Dusty Grey   | RAL 7037   |  | 18   | 6502-B    |
| Dark Grey    | RAL 7015   |  | 8    | 8005-R80B |
| Black        | BS 00 E 53 |  | 4    | 9000-N    |



### Stippled

Finish for Rails, Strip, Handrails, Ultra, Angles, Bed Head Protection and Seating.

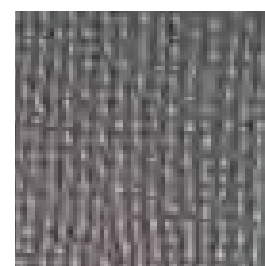

### FalmouthEx & HessianEx

Choice of two finishes for Wall and Door Panels/Plates, Rail Inserts, Door Edges and Door Frame Protection.



### Smooth

Finish for Rigi, Flexi & Maxi Rail, Skirting, Door Frame Protection, Floor Mounted Bollards, Corner Trims and Heavy Duty. (Limited colours, please contact our Sales Office).

### \*LRV - Light Reflectance Value

An LRV is a value given to a surface to denote the amount of light reflected and can be used to measure colour contrast between surfaces. These values have been determined with reference to the CIELAB colour measurement method.

The L co-ordinate represents lightness and extends from 0 (Black) to 100 (White) and has been used as a measure of light reflectance value.

### \*\*NCS Colour References

NCS (Natural Colour System) is a user friendly colour language and is the only colour system that describes colour exactly as we see it. NCS is used by professionals as a tool for precise colour communication, selection and specification.

For further information visit the NCS website - [www.ncscolour.co.uk](http://www.ncscolour.co.uk)



# GENERAL INFORMATION



## Vinylac\*

Most Yeoman Shield products are manufactured using Vinylac, a specially formulated PVCu material that is resistant to impact and abrasion, which is exclusive to Harrison Thompson & Co. Ltd.

## Fire Test Information

### PVCu Protection Products (performed by Warrington Fire Research)

Vinylac has been tested independently of any support or substrate that could be considered to have enhanced its performance.

Tested to BS 476: Part 7: 1987 Method for Classification of the Surface Spread of Flame of Products, Vinylac achieved Class 1Y. Class 1 is the best achievable by the standard (Class 0 is not defined in this standard). The suffix 'Y' denotes softening and/or other behaviour that, in the opinion of the test laboratory, may have had an effect on the flame spread characteristics of the product.

Once Class 1 is achieved then the material may proceed to be tested as a Class 0 product to BS 476: Part 6: 1989 Method of Test for Fire Propagation for products.

Vinylac obtained a result that complies with the requirements of Class 0 as defined in the Approved Document B of the Building Regulations - Fire Safety.

Full test reports are available upon request.

### Door Edge Protectors ® (performed by Chiltern International Fire)

Yeoman Shield Door Edge Protectors satisfied the requirements when tested as below:

Fire tested in accordance with BS 476: Part 22: 1987, for half hour or one hour fire integrity on full door assemblies.

Smoke tested in accordance with BS 476: Part 31.1: 1983, to meet the requirements of BS 5588 and Approved Document B to the Building Regulations - Fire Safety.

Full test reports are available upon request.

### ® Patent applied for (a product developed in association with Lorient Polyproducts Ltd)

## DDA (Disability Discrimination Act)

Various products within the **Yeoman Shield** range help to meet DDA requirements. The Door Edge Protectors in a contrasting colour, such as those shown on page 44, highlight the edge of the door for the partially sighted. Door Protection Panels/Plates, D Plates, Door Frame Protectors and Corner Protection Angles can also be used to identify particular areas within buildings. Handrails and Protection Rails complete with contrasting stop ends and external corners can also be used to indicate changes in direction or termination of area.

The Guardian, Premier and Combined Handrails do not contravene the DDA requirements when installed in either Hospital wards or corridors. The Building Regulations Part M (2004) and the BS 8300:2001 both provide 'guidance' for handrails and their dimensions, but this only applies to handrails that are fitted to **'stairways, external stepped and ramped access.'**

HBN 00-04, Handrails: states that 'Where handrails and wall protectors are required, they may be combined or kept separate' and refer to HTM 69 for further guidance.

Signage can be incorporated into most of our wall and door protection systems. Use of contrasting colours can ensure that they are well defined and legible.

Signs in protection are more easily read by wheelchair users and present no disadvantage to others.

Please also bear in mind that signage can be in hieroglyphics and Braille.

## HTM 69

All Yeoman Shield handrails meet the principals of HTM 69. - "Wood - or MDF - based rails faced with high impact plastics, sometimes edged top and bottom with hardwood, have proved a satisfactory solution to hand/crash rails."

## Installation

Typical Fixing Instructions are shown throughout this brochure. However, if additional information or clarification of any points is required, then please contact our Sales Office.

Our Supply & Fix service is available nationwide on all of our products. We are CHAS (Contractors, Health & Safety Assessment Scheme) accredited contractors and all of our directly employed fixing operatives are CSCS (Construction Skills Certification Scheme) Gold Standard.



## Colours & Finishes

All relevant colours and finishes information is detailed on pages 60 & 61 of this brochure.

## Surfaces & Cleaning

All Yeoman Shield wall protection products are inherently hygienic if they are properly cleaned and maintained. PVCu materials are 'rigid' and do not support the growth of bacteria or mould. When cleaning, we recommend using either a solvent cleaner or products such as Dettol and Johnson's Clear.

Smooth surfaces are more likely to show all marks, scuffs and scratches. The textured surface of Yeoman Shield products helps to hide the everyday knocks, bumps, scratches, marks, etc. caused by vehicular traffic.

## Chemical Resistance

**Vinylac** is unaffected by commercial solvents and cleaners.

## Impact & Abrasion

**Vinylac** results: Abrasion BS 2782: Part 3: 1990 - Scratch ASTM D3363 - 74.

## Expansion & Contraction

Yeoman Shield products will expand and contract according to temperature fluctuations. Generally, PVCu materials expand or contract 0.07mm/m for every one degree Celsius rise or fall.

To allow materials to acclimatise to the environment into which they are being installed they should be stored on site for at least 24 hours prior to fitting at normal working temperature.

**N.B.** Please note that greater movement may occur in glazed corridors.

## Forming Materials

Yeoman Shield wall and door protection materials can be Thermoformed in our workshop to suit special site applications.

Special shapes, panels, features, signage, etc. can also be produced. Please see Yeoman Shield Imagery on pages 28 & 29.

## Bonding Capability

Although Yeoman Shield supplied adhesives will perform in difficult environmental conditions they will activate more readily if applied at normal room temperature.

The bond strength will then continue to increase after the initial application.

## COSHH

Full COSHH (Control of Substances Hazardous to Health) details on all Yeoman Shield products are available from our Sales Office.

## Environmental Policy

Yeoman Shield operates an environmental policy and ensures the recycling of materials and packaging wherever possible.

## Warranty

Yeoman Shield products are guaranteed free from defects. Installed correctly they will protect surfaces from damage for many years.

## Technical Support & Advice

For advice or further information on colours, finishes, stock and samples please contact us on 0113 279 5854.

## Timber Products

Wood incorporated in Yeoman Shield Premier Rails is purchased from an **FSC** supplier.



# YEOMAN SHIELD

WALL & DOOR PROTECTION

OVER 40 YEARS OF SUCCESS

A reputation gained as 'The Market Leader in Wall & Door Protection' for offering a friendly, courteous service with fast delivery of advice and product.



**Harrison  
Thompson**

Making Business a Pleasure

Harrison Thompson & Co Ltd.,  
Yeoman House, Whitehall Estate, Whitehall Road, Leeds, LS12 5JB  
T: 0113 279 5854 F: 0113 231 0406  
E: [sallyann@yeomanshield.com](mailto:sallyann@yeomanshield.com)  
W: [www.yeomanshield.com](http://www.yeomanshield.com)



Harrison Thompson & Co Ltd has a policy of continual product enhancement and reserves the right to alter any specifications without notice. E. & O.E. No part of this publication may be reproduced, stored in a retrieval system, or transmitted, in any form by any means, electronic, mechanical, photographic, recording or otherwise, without the prior permission of Harrison Thompson & Co Ltd. All rights reserved.



ISO 9001 Certificate No 5887