



Avon Barrier Company Ltd

**Avon
Newey
Barrier
Locking
Mechanism**



Avon Newey Barrier Locking Mechanism

The Avon Newey Locking system has been designed to provide an electrically released locking mechanism for retro-fitting that will significantly enhance the security provided by the barrier.

The system is comprised of a pair of 500Kg magnetic locks which are fitted to the barriers arms and lock into a bracketed receptor mounted on the catcher supports. The locks are released by a push button which can be remotely positioned in a secure area and relock as the barrier is closed.

The main benefit of the system is that there is a reduced reliance on the guard holding the barrier in the closed position although the system also enables the barrier to be left in the locked position when unguarded.

Features

- 1,000Kg holding force
- Manufactured from heavy gauge materials
- Remote release facility
- Fully adjustable fixing brackets

Benefits

- Confidence in security performance
- Strength and Durability
- Control from secure location
- Can be fitted to most locally manufactured design interpretations

**Avon Barrier
Company Ltd**
191-195 South Liberty Lane
Ashton Vale Trading Estate
Bristol BS3 2TN UK

TEL +44 (0)117 953 5252
Fax +44 (0)117 953 5373
Email
sales@avon-barrier.com
www.avon-barrier.com
www.avon-barrier.co.uk

Avon Newey Barrier Locking Mechanism

Technical Specification

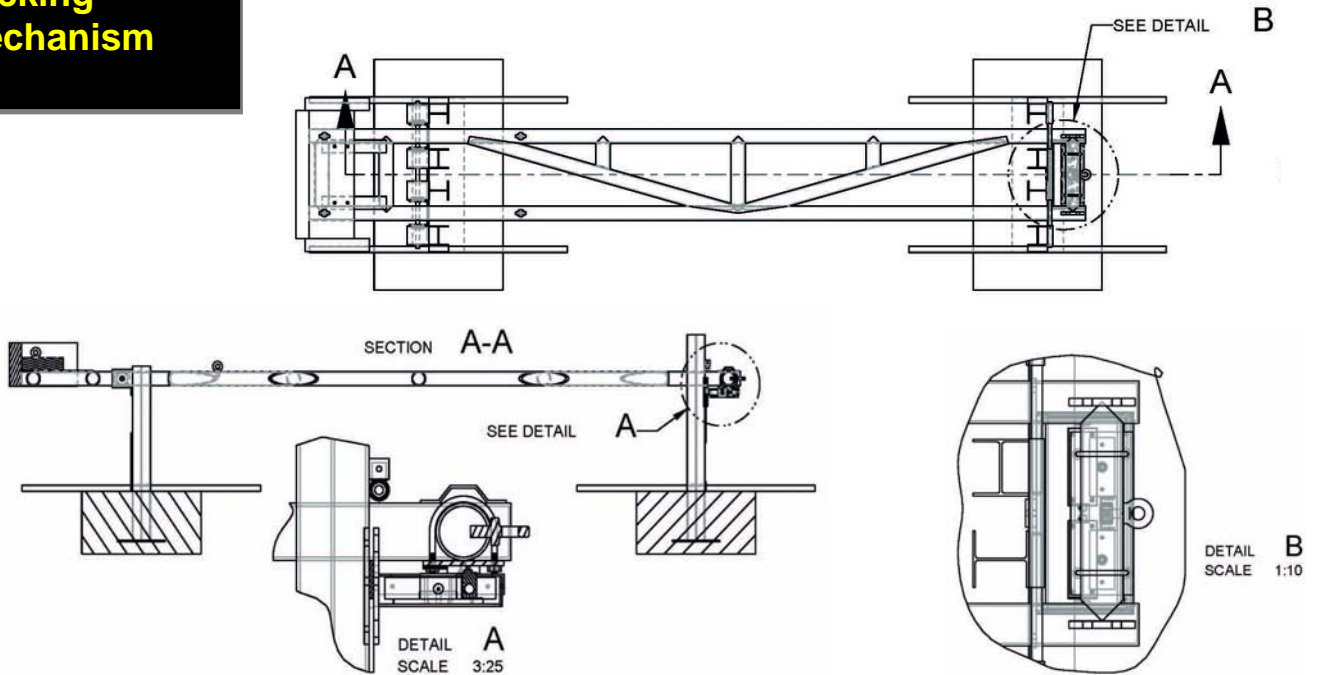

Avon Newey Barrier Locking Mechanism

The locking mechanism is made up of a pair of magnetic locks which are attached to an adjustable cross member that fits between the two barrier boom arms.

A locking plate box is fitted to the barrier end supports using an adjustable bracket.

Control and power supply cables can be run through the barrier arms for added protection against damage or attack.

Remote release button can be fitted in a secure environment eg adjacent gatehouse

Local emergency button can be provided to enable local lock down to override remote release.

Options available

- Release button
- UPS backup
- Lock down emergency button with key reset

Technical Details

Physical Dimensions: Fully adjustable but designed to suit standard Newey design

Power requirements : 220V standard

Locking strength: 1,000KG

Construction: The framework is constructed from fully welded, heavy gauge, steel angle and box sections.



The Avon Barrier Company reserves the right to change or amend the specification of its products from time to time in furtherance of its policy of continued improvements.

REF ABC/Avon Newey Barrier Magnetic Lock/Version 1.1 102009



Avon Barrier Company Ltd

191-195 South Liberty Lane
Ashton Vale Trading Estate Bristol BS3 2TN UK
Tel +44 (0)117 9535 252
Fax +44 (0)117 9535 373
Email security@avon-barrier.com
Website www.avon-barrier.com
www.avon-barrier.co.uk