

INDUSTRIAL

product range

March 08



www.top-tec.co.uk - Order online 24/7



About Top-Tec Industrial

Dalen Limited manufactures the UK's leading ranges of quality forklift truck attachments and physical security products under the Top-Tec brand. The industrial range includes rigid and folding access platforms, tipping pallets, tidy bins, handy bins, self-tipping skips, sump pallets, drum storage, drum trolleys and spill kits.

The Top-Tec Industrial products were originally manufactured by sister company Amington Engineering Co. Limited, which has now been incorporated into Dalen. Amington was established in 1957 and recently celebrated 50 years of design and manufacturing experience. Top-Tec was the original brand for Dalen security products and as a natural progression has expanded to include the Industrial product range.

Top-Tec Industrial continues the tradition of supplying premium quality, innovative products and providing solutions for improved materials handling & storage, waste management and safe working access at height. We manufacture our products to a high specification with safety and longevity essential to the design and development process. They are carefully designed for ease of use, improved efficiency and to withstand the demands of daily use in factories and warehouses.

Providing excellent service from a UK manufacturing base enables Top-Tec Industrial to respond to your requirements rapidly and to offer prompt delivery times. We are a member of the British Industrial Truck Association (BITA) and are approved to ISO 9001:2000.

Why choose Top-Tec Industrial?

- High-quality, robust products made to last
- Products manufactured to ISO 9001:2000
- Excellent customer service
- Bespoke design service for large quantities
- Manufactured in the UK



Dalen headquarters in Birmingham

Folding Access Platforms

- Unique folding design assembles in seconds
- Absolute stability with forks locating in tunnel guides
- Amlock security system locks platform behind heel of forks
- Wheels incorporated so easy to move
- Conforms to PM28

Our unique patented* Folding Access Platforms can be assembled by one person in less than 30 seconds and provide a safe alternative to ladders for occasional access and maintenance work in inaccessible areas.

Available with a choice of base sizes, 1000mm x 1000mm or 800mm x 800mm, and combined with the minimal height when folded, they are easy to transport and store when not in use. They are ideal for mobile service engineers who should carry this kind of equipment for their own protection when they need to work at height.

Both models feature the Amlock security system that can be adjusted to fit various fork sizes and, when locked behind the heel of the forks, prevents the platform from sliding off the forks. They incorporate anchorage points for attaching a safety harness and in-board handles for a secure grip when required. The wire mesh at the rear of the platform provides protection from trapping, crushing and shearing points on the forklift truck.

Tackle maintenance work in safety with our unique Folding Access Platforms.

*Patent No. 2267885B

Optional Accessories:

- Safety harness



AFAP-2M assembly



AFAP-2M



AFAP-2M folded



AFAP-1M



AFAP-1M folded



	Model No. AFAP-2M	Model No. AFAP-1M
Max capacity	2 persons plus tools, 400kg	1 person plus tools, 400kg
Unladen Weight	94kg	78kg
Colour	Yellow / Black	Yellow / Black
Conforms to	PM 28	PM 28
Dimensions		
Size folded	(W) 1000 x (D) 1000 x (H) 270mm	(W) 800 x (D) 800 x (H) 450mm
Size in use	(W) 1000 x (D) 1000 x (H) 1880mm	(W) 800 x (D) 800 x (H) 2100mm
Fork Lift		
Fork guide size	180 x 75 @ 660mm fork centres	180 x 75 @ 525mm fork centres
Minimum truck rating	1000kg @ 600mm load centre	1000kg @ 600mm load centre



TOP-TEC
SAFETY

MK5 Safety Access Platform

- Extra heavy duty construction
- Extra large working area
- Self-closing and latching gate
- Amlock security system locks platform behind heel of forks
- Conforms to PM28

Since we manufactured the first forklift access platform, the range has progressively improved to reflect the latest designs and customer requirements. This has culminated in the top of the range MK5 platform, which is the ultimate solution for occasional overhead access and maintenance work.

The MK5 is a superior, extra heavy-duty safety platform constructed from 50mm square hollow section for additional strength. The platform has a much larger working area than other platforms allowing two people to work with tools in comfort and the slip resistant floor is supplied with convenient drainage holes. The self closing and latching gate automatically locks when the platform is lifted off the ground, thus preventing accidental opening.

The Amlock security system can be adjusted to fit various fork sizes and when locked behind the heel of the forks, prevents the platform from sliding off the forks. The tunnel guides provide absolute stability for the platform once the forks are located into them.

The wire mesh at the rear of the platform provides protection from trapping, crushing and shearing points on the forklift truck. Anchorage points are incorporated to attach safety harnesses and the three safety rails offer extra protection. The set of plastic tool trays supplied can be attached to the louvre panel at the rear of the platform while the practical metal tray fits to the front or side.

The MK5 Access Safety Platform – if you demand the very best for overhead work.

Optional Accessories:

- Removable overhead guard
- Safety harness
- Set of extra plastic bins
- Castors

We also manufacture bespoke electrical access platforms - please contact us for further details

MK5



MK5 with overhead guard

Model No. MK5 Access	
Max capacity	2 persons plus tools, 300kg on 1000kg truck 2 persons plus tools, 800kg on 2000kg truck
Unladen Weight	200kg
Colour	Safety Yellow
Conforms to	PM28
Dimensions	
Cage Size	(W) 1250 x (D) 1250mm x (H) 2200
Fork Lift	
Fork guide size	180 x 75 @ 660mm fork centres
Minimum truck rating	1000kg @ 600mm load centre



MK4 Safety Access Platform

- Heavy duty construction
- Compact one-man design
- Self-closing and latching gate
- Amlock security system locks platform behind heel of forks
- Conforms to PM28

The MK4 is a one-man version of our MK5 Safety Access Platform, incorporating comfort and convenience. It is a heavy-duty safety platform constructed from 50mm x 25mm hollow section for additional strength and the slip resistant floor is supplied with convenient drainage holes. A self closing and latching gate automatically locks when the platform is lifted off the ground, thus preventing accidental opening.

The Amlock security system can be adjusted to fit various fork sizes and when locked behind the heel of the forks, prevents the platform from sliding off the forks. The tunnel guides provide absolute stability for the platform once the forks are located into them.

The wire mesh at the rear of the platform provides protection from trapping, crushing and shearing points on the forklift truck. An anchorage rail is included to allow a safety harness to be attached and the three safety rails offer extra protection. The set of plastic tool trays supplied can be attached to the louvre panel at the rear of the platform while the optional metal tray would fit to the front or side.

The MK4 Access Safety Platform – for frequent, demanding overhead work

Optional Accessories:

- Removable overhead guard
- Safety harness
- Metal tool tray
- Set of extra plastic bins
- Castors

We also
manufacture
bespoke electrical
access platforms -
please contact us for
further details

Model No. MK4 Access	
Max capacity	2 persons plus tools, 350kg
Unladen Weight	105kg
Colour	Safety Yellow
Conforms to	PM28
Dimensions	
Cage Size	(W) 1000 x (D) 1000mm x (H) 2085
Fork Lift	
Fork guide size	180 x 75 @ 660mm fork centres
Minimum truck rating	1000kg @ 600mm load centre

MK4



MK4 with overhead guard



Economy Access Platform

- Ideal for occasional light duty maintenance
- Amlock security system locks platform behind heel of forks
- Absolute stability with forks locating in tunnel guides
- Solid slip resistant floor with drainage holes
- Conforms to PM28

The Economy Access Platform is a basic, cost effective and popular model that is ideal for occasional light duty maintenance and access use.

The Amlock security system can be adjusted to fit various fork sizes and when locked behind the heel of the forks, prevents the platform from sliding off the forks. The tunnel guides provide absolute stability for the platform once the forks are located into them.

The wire mesh at the rear of the platform provides protection from trapping, crushing and shearing points on the forklift truck. An anchorage rail is included to allow a safety harness to be attached and the two safety rails offer additional protection. The louvre panel at the rear of the platform will accept the optional plastic bins while the optional metal tray can fit to the front or side.

Whether you need to change a light bulb, paint the roof, clear a gutter or do almost any other infrequent task above the ground, the job will be safer and easier with a Top-Tec Economy Access Platform.

Optional Accessories:

- Removable overhead guard
- Safety harness
- Metal tool tray
- Range of plastic bins
- Castors

Model No. Econaccess	
Max capacity	2 persons plus tools, 400kg
Unladen Weight	95kg
Colour	Safety Yellow
Conforms to	PM28
Dimensions	
Cage Size	(W) 1000 x (D) 1000mm x (H) 2100
Fork Lift	
Fork guide size	180 x 75 @ 660mm fork centres
Minimum truck rating	1000kg @ 600mm load centre



Econaccess

Econaccess with overhead guard



Spill Control Kits

- Aids compliance with ISO 14001
- Available as oil, chemical or maintenance kits
- Kits for internal or external use
- Wide range to suit most applications

Our range of spill kits complement our drum storage solutions and can be used anywhere, inside or outside the workplace, for cleaning up all types of spillages

Spill Kits 1, 2 & 3 can be hung on the wall with fire extinguishers, first aid kits etc for a complete emergency station. They can be carried in cars for fast response or placed outside in high risk areas such as drum storage and transfer areas. They are supplied in a strong UV stabilised waterproof double zipped PVC bag.

Spill Kits 4, 5 & 6 are essential for spill response plans and ideal for meeting the requirements of ISO14001. Use in lubricant dispensing areas, loading bays, flammable and drum stores or hold centrally for mobile emergency response. They are supplied in a tough lightweight wheeled container.

Spill Kits 7, 8 & 9 are primarily for outdoor use for dealing with spills that pose an environmental threat at bulk fuel or chemical storage, waste oil collection points, fuel delivery points and near high risk areas such as rivers and canals. They are supplied in a mobile heavy duty, UV stabilised waterproof container with a lockable lid for security.

Each spill kit is available in oil, chemical or maintenance options and the contents are colour coded for easy identification.

Spill Kit 1



Spill Kit 7



Spill Kit	Forklift	1	2	3	4	5	6	7	8	9
Absorbency Chemical & Maintenance (Ltr)	4	36	48	60	69	160	235	104	174	267
Absorbency Oil (Ltr)	-	60	79	97	112	254	373	165	277	489
Size (cm)	50 x 28 x 7	50 x 50 x 18	50 x 50 x 26	50 x 50 x 35	61x 51 x 53	104 x 75 x 74	140 x 80 x 91	240 litre	340 litre	660 litre
Pads 40 x 52cm	8	25	50	75	50	150	200	150	150	100
Mini Roll 40 x 52cm	-	-	-	-	-	-	-	1	1	-
Socks 125 x 7.5cm	-	4	4	4	5	6	10	5	5	12
Socks 3m x 7.5cm	-	-	-	-	2	4	5	1	-	-
Boom 4m x 20cm	-	-	-	-	-	-	-	-	1	2
Boom 3m x 12.5cm	-	-	-	-	-	1	2	-	-	-
Cushions 55 x 35 x 10cm	-	2	2	2	3	4	6	2	2	12
Dammit Slab	1	1	1	1	-	-	-	-	-	-
Dammit Mat 65 x 45cm	-	-	-	-	-	-	-	1	1	1
Dammit 800g	-	-	-	-	1	1	1	1	1	1
Particulate 4kg	-	-	-	-	-	-	-	-	-	1
Disposal Bags & Ties	1	1	1	1	4	10	20	3	3	12
Stakes	-	-	-	-	-	-	-	-	2	2
Personal Safety Kit	-	-	-	-	-	-	-	1	1	1
Gloves & Goggles	1	1	1	1	1	1	1	-	-	-



Bunded Metal Drum Storage

- Robust steel construction
- Exceeds PPG26 (Feb 2004) containment recommendations
- Stores up to 8 drums vertically, 6 drums horizontally, a combination of both or 1 x IBC container
- 4-way fork guides for a safe and secure lift
- Available in Poppy Red as standard

Pollution resulting from the spillage of hazardous liquids, either deliberately or accidentally, can be dangerous and is a serious offence. This can often result in costing thousands of pounds in fines and clean-up charges. To help to prevent this from happening, Top-Tec Industrial offer a comprehensive range of drum storage systems to store between one and eight 205 litre drums.

They are manufactured to contain at least 25% of the total volume stored or 110% of the largest container, whichever is the greater, exceeding PPG26 (Feb 2004) containment recommendations. Additionally, they incorporate a 4-way forklift entry for a safe, secure lift.

If you handle oil or other dangerous liquids, protect your personnel and organisation by storing your drums in a Top-Tec Industrial drum storage system.

NB. Do not lift when loaded with drums.

Optional Extras

- Drain pump
- Security cover
- Other colours available subject to consultation



AMDV2



AMDV2

Model No.	Description	Drum Capacity (205 litre)	Width (mm)	Depth (mm)	Height (mm)	Sump Capacity	
						Litres	% of min PPG26 requirements
AMDH1	Horizontal Drum Stand	1 - Horizontal	799	1524	1400	235	104%
AMDH2	Horizontal Drum Stand	2 - Horizontal	1524	1524	1400	470	209%
AMDH4	Horizontal Drum Stand	4 - Horizontal	1524	1524	2150	470	209%
AMDH6	Horizontal Drum Stand	6 - Horizontal	1524	1524	2900	470	153%
AMDV1	Vertical Drum Stand	1 - Vertical	799	799	1625	230	102%
AMDV2	Vertical Drum Stand	2 - Vertical	1524	799	1400	235	104%
AMDV4	Vertical Drum Stand	4 - Vertical	1524	1524	1625	470	209%
AMDV8	Vertical Drum Stand	8 - Vertical	1524	1524	2900	470	115%
AMDH2V4	Horizontal & Vertical Drum Stand	2 - Horizontal 4 - Vertical	1524	1524	2675	470	153%
AMIBC*	IBC Stand	1 x IBC	1524	1524	1925	1115	102%

* Please note: IBC standard colour is Grass Green

Outdoor Drum Storage

- Robust steel construction
- Exceeds PPG26 (Feb 2004) containment recommendations
- Locking doors to deny unauthorised access
- Gas strut supported lid
- 4-way fork guides for a safe and secure lift

The Environment Agency is continuing to enforce oil store regulations. Any organisation storing more than 200 litres at an industrial, commercial or institutional site must use some form of fully enclosed storage device whenever drums of hazardous liquid (including oils) are stored outside. Bunded Outdoor Drum Storage systems help you to comply with these regulations.

The range of models includes 4 horizontal, 4 vertical, 1 combination and an IBC solution to provide safe and secure storage. They all have lockable doors, adjustable feet (for uneven ground) and a gas strut support lid.

Don't be caught out - ensure that you comply with the regulations with the help of our durable Bunded Outdoor Drum Storage.

NB. Do not lift when loaded with drums.

Optional Accessories:

- Drain pump
- Other colours available subject to consultation



Model No.	Description	Drum Capacity (205 litre)	Width (mm)	Depth (mm)	Height (mm)	Sump Capacity	
						Litres	% of min PPG26 requirements
AMDH1D	Horizontal Drum Stand	1 - Horizontal	852	1577	1460	235	104%
AMDH2D	Horizontal Drum Stand	2 - Horizontal	1577	1577	1460	470	209%
AMDH4D	Horizontal Drum Stand	4 - Horizontal	1577	1577	2210	470	209%
AMDH6D	Horizontal Drum Stand	6 - Horizontal	1577	1577	2960	470	153%
AMDV1D	Vertical Drum Stand	1 - Vertical	852	852	1685	230	102%
AMDV2D	Vertical Drum Stand	2 - Vertical	1577	852	1460	235	104%
AMDV4D	Vertical Drum Stand	4 - Vertical	1577	1577	1685	470	209%
AMDV8D	Vertical Drum Stand	8 - Vertical	1577	1577	2960	470	115%
AMDH2V4D	Horizontal & Vertical Drum Stand	2 - Horizontal 4 - Vertical	1577	1577	2735	470	153%
AMIBCD*	IBC Stand	1 x IBC	1577	1577	1985	1115	102%

* Please note: IBC standard colour is Grass Green



TOP-TEC
STORAGE

Metal Sump Pallets

- Robust steel construction
- Exceeds PPG26 (Feb 2004) containment recommendations
- Store up to 4 drums vertically, or 1 x IBC container
- 4-way fork guides for a safe and secure lift
- Available in Poppy Red as standard

Top-Tec Industrial Metal Sump Pallets offer a robust alternative to our popular plastic sumps. The range has been further improved to facilitate easier loading and greater stability.

They are manufactured to contain at least 25% of the total volume stored, or 110% of the largest container, whichever is the greater. The pallets are available to store one, two or four 205 litre drums, and there is also a solution for IBC containers.

These pallets are manufactured from heavy-duty steel and feature a tough galvanised steel grill that offers maximum strength and is easily removed to allow access for cleaning. They also have 4 way forklift entry for a safe, secure lift.

The hardwearing alternative to plastic sumps - the Top-Tec Industrial range of metal sump pallets.

NB. Do not lift when loaded with drums.

Optional Extras

- Drum saddles for 1 or 2 horizontal drum storage
- Other colours available subject to consultation

AMDP2



AMDP4 with AMDS1



AMDP4

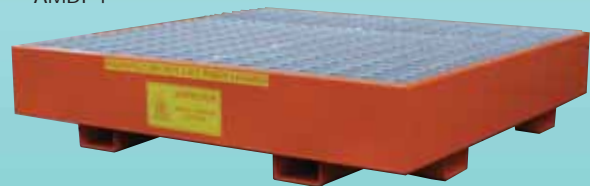

Model No.	Description	Drum Capacity (205 litre)	Width (mm)	Depth (mm)	Height (mm)	Sump Capacity	
						Litres	% of min PPG26 requirements
AMDP1	Metal Sump Pallet	1 - Vertical	785	785	550	230	102%
AMDP2	Metal Sump Pallet	2 - Vertical	1450	725	308	235	104%
AMDP4	Metal Sump Pallet	4 - Vertical	1450	1450	308	470	209%
AMIP	Metal Sump Pallet	1 - IBC	1450	1450	618	1115	102%

Plastic Sump Pallets

- Durable and easy to clean
- Manufactured from non-corrosive plastic
- Holds 4 x 205 Litre drums vertically
- Galvanised steel grill for maximum strength
- Fork guides for a safe and secure lift

Our moulded plastic sump pallets can retain up to 350 litres of chemicals, oils or other hazardous liquids and are supplied in a bright yellow colour for safety.

The pallets are designed to store up to 4 x 205 litre drums vertically or 2 x 205 litre drums horizontally with an optional drum saddle. The saddles can be easily attached with a clip on mechanism.

Manufactured from heavy-duty non-corrosive plastic, the pallets feature a robust galvanised steel grill to offer maximum strength. The grill is easily removable to allow access for cleaning. Other features include fork lift entry and an optional stacking system to store the pallets when empty.

An inexpensive way to help prevent spillage - the Top-Tec Industrial plastic sump pallet.

NB. Do not lift when loaded with drums.

Optional Accessories:

- Drum saddles for 1 or 2 horizontal drum storage
- 'Clip Stacking system



AMPSP4 with AMDS1 saddle



AMPSP4

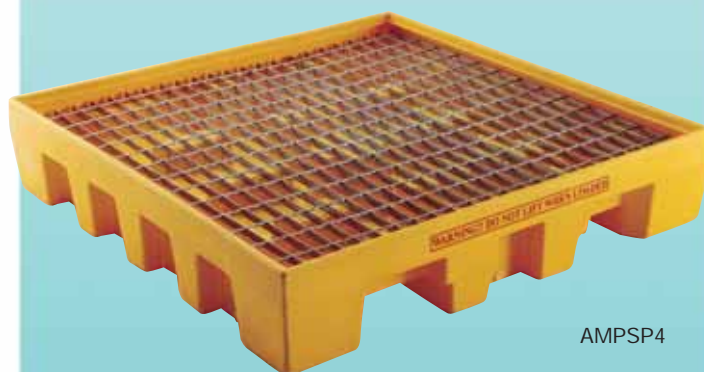

AMPSP4

Model No.	Description	Drum Capacity (205 Litre)	Width (mm)	Depth (mm)	Height (mm)	Sump Capacity	
						Litres	% of min PPG26 requirements
AMPSP4	Plastic Sump Pallet	4 - Vertical	1450	1450	280	350	155%
AMDS1	Saddle to convert to 1 drum horizontal use	1 - Horizontal	740	680	480	-	-
AMDS2	Saddle to convert to 2 drum horizontal use	2 - Horizontal	1440	680	480	-	-



TOP-TEC
STORAGE

Drum Trolley

- Moves and stores 2 drums vertically or 1 drum horizontally with drum saddle
- Holds 235 litres of spillage
- Fork guides for a safe & secure lift
- Heavy-duty castors for easy mobility

The Top-Tec Industrial Drum Trolley serves as an ideal tool for moving and dispensing hazardous liquids around your plant. The trolley can store 2 drums vertically or one drum horizontally on an optional drum saddle. Fork guides allow the safe lifting of the unit and the large castors make this model particularly easy to manoeuvre. If you need to move your chemicals or oils for regular use but require the security of a drum storing system, the Top-Tec Industrial Drum Trolley is the perfect solution.

NB. Do not lift when loaded with drums.

Optional Accessories:

- Drain pump
- Colour change
- Galvanised steel
- Drum saddle for horizontal drum storage
- Drum securing harness

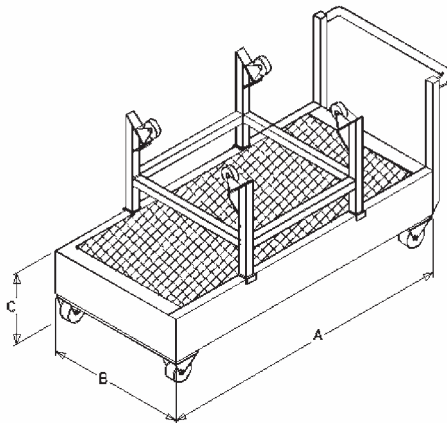

AMDT with AMDS1



AMDT

Model No.	Description	Drum Capacity (205 Litre)	Width (mm)	Depth (mm)	Height (mm)	Sump Capacity (Litre)	% of min PPG26 requirements
AMDT	Mobile Drum Handling Trolley	2 - Vertical	1615	725	1000	235	104%
AMDS1	Saddle to convert to 1 drum horizontal use	1 - Horizontal	740	680	480	-	-

TIPPING SKIPS

Handling

Mini Self Tipping Skips

- Safe and secure in use
- Self-latching tipping mechanism
- Easy fork mounting
- Castors allow pedestrian operation
- Low maintenance

Mini in name, mighty in action, these go anywhere compact, low maintenance skips have been designed to facilitate the easy collection of scrap in confined areas

Whilst being strong and robust in design, their mobility, low weight and overall dimensions allow them to fit where other skips couldn't. The removal of production waste is a lot easier using a Top-Tec Industrial Mini Skip.

Our Mini Skips are ideally suited for use in production areas where space is limited e.g. under CNC machines, power presses and other production machines.

Go anywhere:

- Under CNC machines
- Under power presses
- Under drilling machines
- Under routing machines
- Under turret presses
- Under cut off saws
- Under guillotines
- Under work stations
- And under many more...

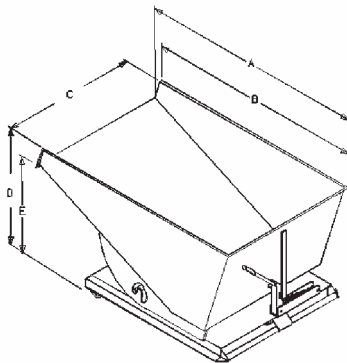

AMS-600



AMS-600

Overall sizes of the Mini Skips: (mm)

Model	Length	Width	Height
AMS-450	840	450	480
AMS-600	840	600	480
AMS-750	840	750	480

Important Recommendation:

The total weight of the skip plus load should not exceed 50% of the fork truck rating. Consideration should be given to the fact that the centre of gravity of the load will move forwards / backwards / sideways when tipping.

Model Number	Capacity M ³	Capacity Kg	Unladen Weight Kg	A	B	C	D	E	Centres Fork	Aperture Fork	Rear - Y	Centres	Standard Colour
AMS-450	.10	200	37	840	760	450	480	380	226	150x65			Orange
AMS-600	.15	200	44	840	760	600	480	380	346	180x65			Orange
AMS-750	.19	200	51	840	760	750	480	380	496	180x65			Orange

Options Note: Please contact us regarding any special options required

Options available for all models	Part No.
Oil tight tested	OT
Oil drain tap	OD
Colour change	CC
Special castors	SC
Stainless steel	SS



TOP-TEC
HANDLING

Self Tipping Skips

- Simple to empty
- Self-latching return mechanism
- Tip in-line (all models) or to either side (3W models)
- Heavy-duty castors ensure they are simple to move (025 & 050 models)
- Robust fork guides for added strength

These durable, low-maintenance heavy-duty skips are suitable for demanding industrial use in factories, warehouses and on building sites. Our skips are designed for forklift truck emptying and will handle almost any kind of material.

The self-tipping skips can easily be emptied by lifting on a forklift truck from the rear (all models) or from either side (3W) and are designed for long and arduous service.

If you are looking for a premium quality skip at an exceptional price, then look no further.



ATS 3W-025



ATS 3W-025 & ATS 1W-100

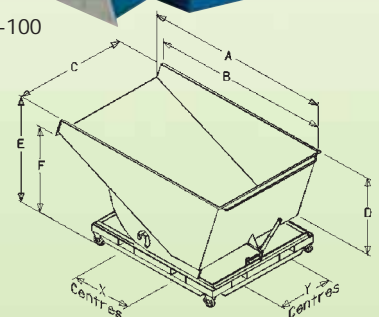

Overall sizes of the Self Tipping Skips: (mm)			
Model	Length	Width	Height
025	1,390	820	900
050	1,740	1,030	1,040
100	2,110	1,310	1,060
120	2,080	1,310	1,180
150	2,390	1,490	1,180
200	2,390	1,745	1,180

Options	Part No.	ATS 3W-025	ATS 1W-025	ATS 3W-050	ATS 1W-050	ATS 1W-100	ATS 1W-120	ATS 1W-150
Oil tight tested	OT	✓	✓	✓	✓	✓	✓	✓
Security lids	SL	✓	✓	✓	✓	✓	✓	✓
Swarf separation plate	SS	✓	✓	✓	✓	✓	✓	✓
Oil drain tap	OD	✓	✓	✓	✓	✓	✓	✓
Colour change	CC	✓	✓	✓	✓	✓	✓	✓
Special fork guides	SF	✓	✓	✓	✓	✓	✓	✓
Special castors	SC	✓	✓	✓	✓	-	-	-

Important Recommendation:

The total weight of the skip plus load should not exceed 50% of the fork truck rating. Consideration should be given to the fact that the centre of gravity of the load will move forwards / backwards / sideways when tipping.

Options Note: Please add the Part Number to the Tipping Skip when ordering eg:- **ATS 3W-025/SL/CC=Red**

Model Number	Capacity M ³	Capacity Kg	Unladen Weight Kg	A	B	C	D	E	F	Aperture Fork	Rear - Y Centres	Sides - X Centres	Castors	Standard Colour
ATS-3W-025	.25	750	155	1250	1200	760	500	900	730	180 x 75	650	710	Steel	Blue
ATS-1W-025	.25	750	155	1250	1200	760	500	900	730			-	Steel	
ATS-3W-050	.50	1250	250	1515	1450	960	640	1040	825			710	Steel	
ATS-1W-050	.50	1250	250	1515	1450	960	640	1040	825			-	Steel	
ATS-1W-100	1.00	1750	400	1920	1870	1210	790	1070	890			-	If Req.	
ATS-1W-120	1.20	1750	425	1970	1840	1210	905	1175	895			-	If Req.	
ATS-1W-150	1.50	1750	500	2190	2140	1375	905	1175	995			-	If Req.	
ATS-1W-200	2.00	1750	655	2190	2140	1630	905	1175	995					

Unless stated, measurements are in mm

Eco Self Tipping Skips

- Simple to empty
- Self-latching return mechanism
- Hoppers constructed in durable 2 or 3mm plate
- Easy fork mounting
- Robust fork guides for strength

Our range of low maintenance Eco Self Tipping Skips is the perfect tool for handling waste and scrap in factories and warehouses. Our skips are designed for forklift truck emptying and will handle almost any kind of bulky material.

The Eco skips feature robust fork guides to allow lifting and tipping/emptying from the rear.

Tipping is activated via manual release levers that are operated from either side and feature a self-latching return mechanism.

All skips are supplied with mounting holes for castors offered as an optional extra. The 0.25 and 0.50 models are designed to take 100mm castors (the overall height increases by 50mm) and the 0.75 and 1.00 models are designed to take 125mm dia. castors (the overall height increases by 75mm).

Optional extras:

- Heavy-duty castors
- Folding cover

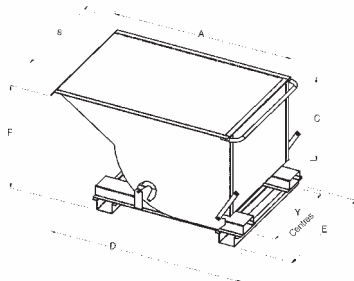

Important Recommendation:

The total weight of the skip plus load should not exceed 50% of the fork truck rating. Consideration should be given to the fact that the centre of gravity of the load will move forwards / backwards / sideways when tipping.

ATS-ECO-025



ATS-ECO-025



ATS-ECO-025 with optional castors



Model Number	Capacity M ³	Capacity Kg	Unladen Weight Kg	A	B	C	D	E	F	Aperture Fork Rear - Y Centres	Standard Colour
ATS-ECO-025	0.25	750	95	960	865	460	1090	950	675	145 x 70	Yellow
ATS-ECO-050	0.50	750	115	1365	865	450	1495	950	865		
ATS-ECO-075	0.75	750	160	1670	865	780	1795	950	1000		
ATS-ECO-100	1.00	1250	185	1925	865	900	2055	950	1115		



BOTTOM EMPTYING BINS

Handling

Handy Bins

- Safe and secure in use
- Open top for fast loading
- Drop bottom base with self-closing latches
- Reinforced fork guides to simplify unloading
- Castors ensure they are simple to move (AHB-10 & AHB-15 only)

Our Handy Bins enable fast and clean handling of lightweight and bulky production waste. Just fill it up, push it out of the way and use a forklift to dump the contents or to stack it on the optional special plinth.

Designed with a clear open top, a drop-bottom base panel restrained by double spring tensioned chains and self-closing latches, this is an ideal tool for disposing of all kinds of light production waste.

The reinforced fork guides are mounted at the top of the Handy Bin to provide a clear exit when emptying. The AXHB 10 Extra Heavy Duty Handy Bin has crane points on the top to allow chains to be attached for moving

The standard finish for these mobile units is Golden Yellow or Grass Green gloss paint on an anti-corrosive primer base.

Optional Accessories:

- Colour change - Red, Blue, Orange and Black
- Base plinth for stacking

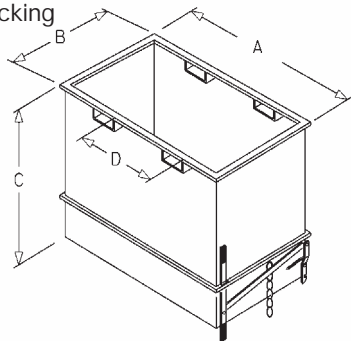

AHB 15-Y



AXHB 10-B

AHB 15-Y



	Model No. AHB 10	Model No. AHB 15	Model No. AXHB 10
Capacity (m ³)	1.0m ³	1.5m ³	1.0m ³
Capacity (kg)	750kg	750kg	2,000kg
Unladen Weight	150kg	190kg	340kg
Outside Dimensions			
Overall Length (A)	1650mm	1650mm	1150mm
Overall Width (B)	1020mm	1020mm	1130mm
Overall Height (C)	970mm	1320mm	1250mm
Base size	1500 x 906mm	1500 x 906mm	1010 x 1010mm
Fork Tunnels			
Centres (D)	660mm	660mm	660mm
Pocket Size	180 x 75mm	180 x 75mm	180 x 75mm

Handling **BOTTOM EMPTYING BINS**

Tidy Bins

- Safe and secure in use
- Hinged lids to secure contents
- Drop bottom base with self-closing latches
- Fully enclosed fork guides
- Castors ensure they are simple to move

Top-Tec Industrial Tidy Bins are ideal for light waste in your warehouse or factory. They feature two large opening doors on the top that allow easy access for loading and help to protect the contents from fire and pollution. Optional gas struts are available to hold the doors open when loading.

The Bins are emptied via a drop bottom base restrained by double spring tensioned chains and incorporates self-closing latches. Fully enclosed fork guides are mounted at the top to enable a completely clear exit of the waste and no forklift modification is required to lift them. The bins are fitted with heavy-duty castors to ensure that they are easy to move.

Available in attractive Golden Yellow or Grass Green gloss finish on a primer base, these attachments will offer you speedy and efficient waste removal.

Optional Accessories:

- Colour change - Red, Blue, Orange and Black
- Gas struts

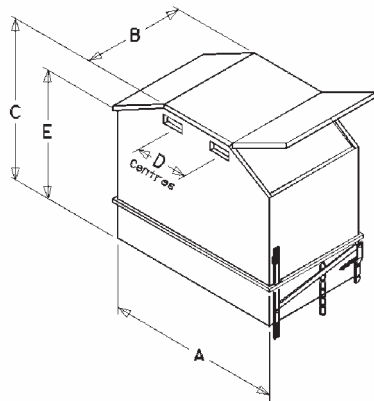

ATB 10-G



ATB 15-Y

ATB 10-G

	Model No. ATB 10	Model No. ATB 15
Capacity (m ³)	1.0m ³	1.5m ³
Capacity (kg)	350kg	350kg
Unladen Weight	150kg	190kg
Overall Length (A)	1650mm	1650mm
Overall Width (B)	1020mm	1020mm
Height off the floor (C)	1120mm	1420mm
Height from the floor to lip (E)	860mm	1160mm
Base size	1500 x 906mm	1500 x 906mm
Loading apertures	390 x 850mm	390 x 850mm
Fork Tunnels		
Centres (D)	444mm	444mm
Pocket Size	180 x 75mm	180 x 75mm



TOP-TEC
HANDLING

Euro Pallet Truck

- Safe and secure in use
- Robust, hardwearing construction
- Straightforward operation
- Prevents forklift misuse
- Self-latching tip mechanism

The Euro Tipping Pallet will handle almost any kind of boxed or flat packed material. The self-tipping unit is activated by releasing a spring mechanism and is designed for arduous service.

Typical applications include the unloading of balers and other items that need to be discharged from the forks of a truck.

Make the handling of flat packed waste easy with the Top-tec Tipping Euro Pallet!

Optional Accessories:

- Colour change

	Euro Tipping Pallet Model No. AETP
Max capacity	1000kg
Unladen Weight	68kg
Colour	Yellow
Dimensions	
Size in use	(W) 1250 x (D) 1000mm x (H) 160mm
Fork Lift	
Fork guide size	150 x 70 @ 700mm fork centres
Minimum truck rating	1000kg @ 600mm load centre



Hand Pallet Truck

- Capacity of 2000kg or 2500kg
- Strong steel frame with slow lowering when loaded
- Over-load protection
- Valve as a whole item allows easy servicing
- Fully adjustable push rods under forks ensure stability of forks
- Durable polyurethane front wheel and double back rollers
- Excellent turning angle of 190°
- Greasing points

Top quality pallet trucks with up to 2500kg lift capacity!



	TTA PT 20 x 1000	TTA PT 20 x 1150	TTA PT 25 x 1220
Capacity (kg)	2000	2000	2500
Height lowered (mm)	75	75	83
Max. height (mm)	185	185	195
Load wheel (mm)	ø73x94	ø73x94	ø80x68
Length of fork (mm)	1000	1150	1220
Overall fork width (mm)	520	550	685
Overall length (mm)	1360	1510	1580

Products supplied on pallet as 'knock downs' and simply require the handle attaching to the frame.

Scissor Pallet Truck

- Reduces injuries through heavy lifting
- Fully enclosed manual hydraulics
- Stabilising and secure side support bars when static
- Manually controlled descending speed
- Controlled lift (12mm per stroke)

The scissor lift will help you to work at an ergonomic working height!



	TTA PTS 10 x 1140
Capacity (kg)	1000
Height lowered (mm)	90
Max. lifting height (mm)	800
Load wheel (mm)	ø80x50
Length of fork (mm)	1140
Overall fork width (mm)	685
Overall length (mm)	1480

Products supplied on pallet as 'knock downs' and simply require the handle attaching to the frame.



TOP-TEC
HANDLING



Products from the Top-Tec Industrial range:

Safety

- Access platforms
- Safety harnesses
- Folding access platforms
- Spill kits

Storage

- Drum storage
- Drum trolleys
- Sump pallets
- Drum handling

Handling

- Self-tipping skips
- Tipping pallets
- Handy bins
- Pallet trucks
- Tidy bins

Products from the Top-Tec Security range:

ICT Security

- Tower, desktop, & server enclosures
- Laptop NightSafes
- Laptop brackets & desk mounted enclosures
- Secure cables
- Flat panel brackets and mounts
- Media trolleys
- Rack cabinets

Furniture

- Venus cantilever desks
- Corner and Cluster desks
- Mars standard desks
- Drawer and storage solutions
- Multi-function desks
- Electronic height adjustable desks

Audio-Visual Security

- Projector enclosures
- Columns and brackets
- Secure and non-secure ceiling units
- Only available from authorised resellers



Quality Systems Certificate No. 812
Assessed to ISO 9000

Why choose Top-Tec Industrial?

- High-quality, robust products made to last
- Products manufactured to ISO 9001:2000
- Excellent customer service
- Bespoke design service for large quantities
- Manufactured in the UK

Dalen Limited, Valepits Road, Garretts Green, Birmingham B33 0TD
Tel: 0121 783 3838 Fax: 0121 784 6348 industrial@top-tec.co.uk

www.top-tec.co.uk