

# PUSH UP AND DIP

WD-1021BHG Push Up and Dip

## STRENGTH EXERCISES

- UPPER BODY
- ARMS
- SHOULDERS
- BACK

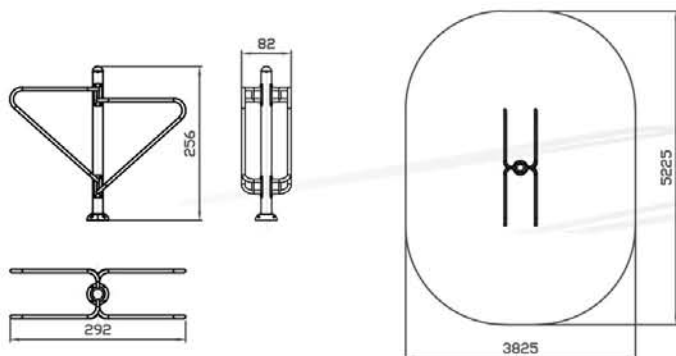

Dimensions are in mm.  
Do not scale from drawing.

Our fitness equipment provides opportunities for users to enjoy exercise outdoors. The range offers a wide range of activities, including upper and lower exercises through cardiovascular training, flexibility and strength training.

These are an excellent edition to any public space to encourage good health and wellbeing, without the pressures of a private gym environment.