



SOLUTIONS FOR
STEEL
APPLICATIONS

TECHNOLOGY OVERVIEW

LUMASENSE SOLUTIONS FOR STEEL APPLICATIONS

LumaSense Technologies, Inc. delivers innovative temperature monitoring solutions throughout steel making, forming, and finishing processes.

Today's increasing quality standards and higher energy costs demand more accurate and consistent temperature control in the steel making process. Processes such as coke oven heating, continuous casting, furnace reheating, hot rolling, and forging are becoming more and more expensive. Steel facilities need the right tools to ensure they optimize energy usage across their facilities.

With a 60-year history of creating efficiencies through light-based measurement, LumaSense Technologies is an industry leader in process monitoring and delivers innovative temperature measurement instruments for all areas of steel manufacturing.

Our thermal imagers and pyrometers provide the steel industry with cutting-edge technology, ease-of-use, and dependability for monitoring critical parameters for productivity and product quality. These solutions are used throughout the steel manufacturing process, where accurate temperature monitoring is required for improved control.

LumaSense addresses these needs by providing the most accurate measurements in the industry, enabling steel facilities to maximize their output. These solutions are developed specifically for high temperature applications in the steel and primary metals industries.

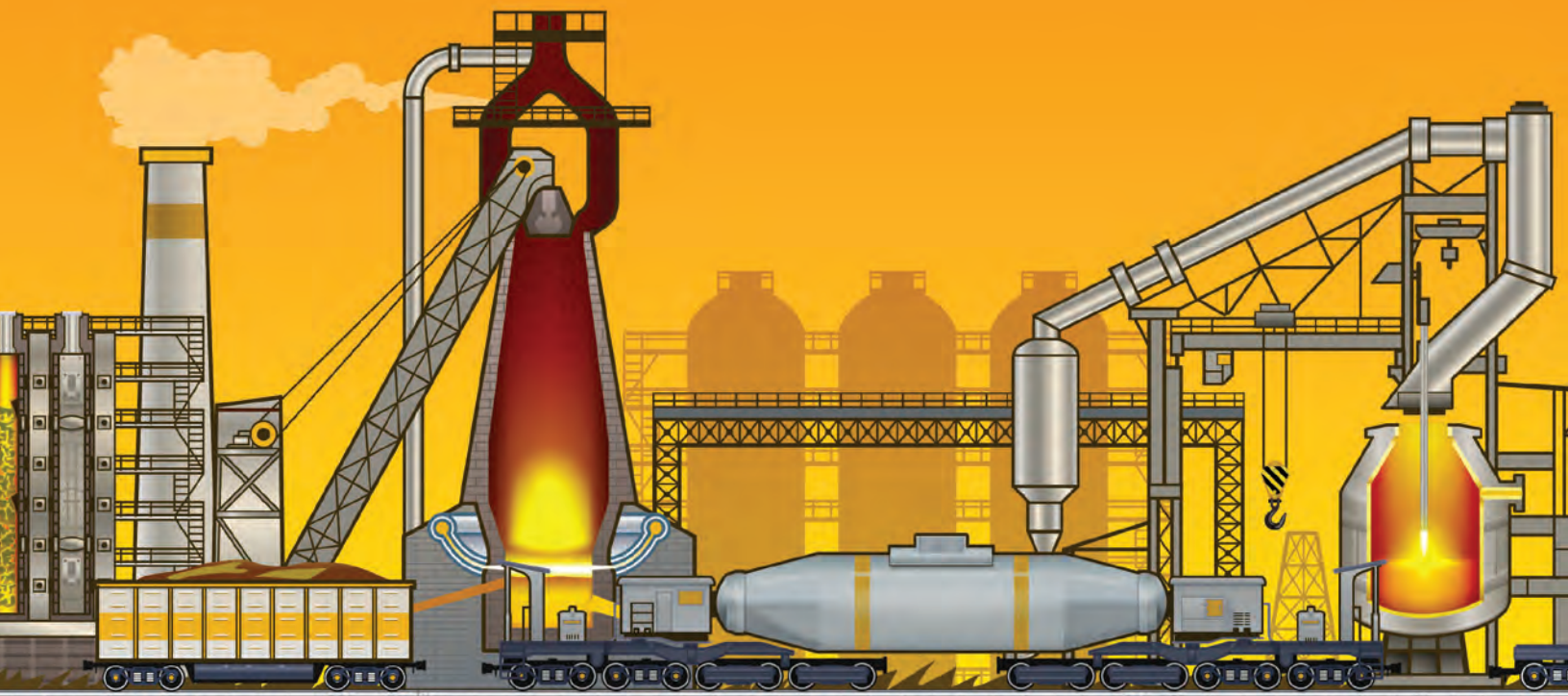

Our Technologies

Better Processes with Better Measurements

THERMAL IMAGING SOLUTIONS

Our thermal imaging solutions offer excellent spatial and temperature resolution for outstanding images, allowing users to gain new insight into their processes. Designed specifically to protect instruments in harsh, high-temperature steel environments, advanced enclosures allow for remote monitoring of temperatures in real time, and for image data to be transferred from one or more cameras to a single PC. The instruments are insulated and cooled to protect the temperature measurement device and to maximize efficiency, while ensuring safe continuous operation. Our LumaSpec™ software programs offer high-speed real-time data acquisition and leads the industry for image analysis capabilities.

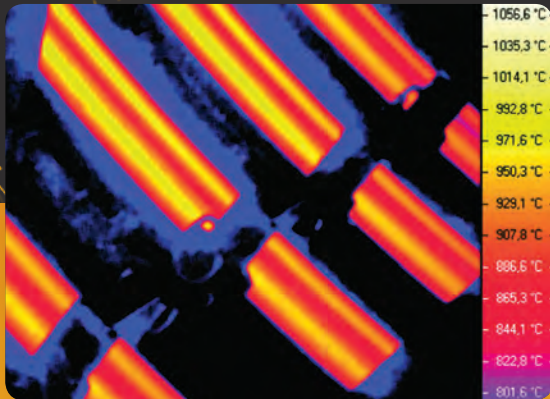

PYROMETRY SOLUTIONS

LumaSense offers the industry's broadest selection of pyrometers with features designed specifically for high-temperature steel processing. Short wavelength (near infrared) provides higher accuracy measurements demanded for precise process control. Designed for accurate measurements in dirty, hot environments, our two-color (ratio) pyrometers are ideal for applications with steam, smoke, and dust. Measurements are usually unaffected by dust and other contaminants in the field of view or by dirty viewing windows. In addition, the temperature measurement is usually independent of the emissivity of the object in wide ranges, and the measuring object can be smaller than the spot size.

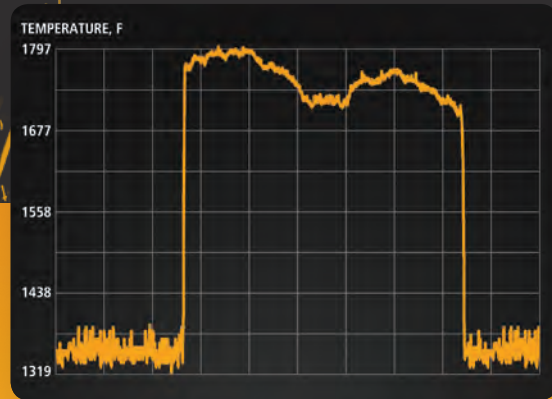

Coke ovens, wharfs, and raw materials transport

Coke is the most important raw material for the blast furnace in terms of operation and hot metal quality.

Detection of hot spots during the rail car transport or wharf quenching can reduce safety risks and prevent damage to equipment, such as conveyor belts.

In the coke oven battery, operators look for even heat distribution over the entire heating wall for coking process optimization and efficiency. Residue and deposits on the heating walls can impact the quality of the coking process and result in production losses and high costs on a restart.

Our IMPAC IGA 315-K and IS 8 pro portable pyrometers offer extremely accurate temperature measurements in coke ovens flues and prior to push. The focusable optics and compact design allow for easy operation and data capture during the measurement process.

We can automatically and remotely monitor rail cars, cooling wharfs, and edge-to-edge on a transfer belt using the MIKRON MC320 to detect true hot spots. LumaSense's software and related I/O systems allow for automated process monitoring to reduce equipment downtime.

KEY PRODUCTS

Pyrometers: IGA 315-K,
IS 8 pro, IS 6, IS 6 TV

Thermal Imagers:
MC320 Series





Stove dome & blast furnace

Stove domes contain extremely volatile gases used to heat the blast furnaces along with waste gases, both of which can reach up to 2600 °C.

Temperature measurement and control is essential for maintaining correct operation. Manufacturers typically use expensive thermocouples to measure the air and refractory wall temperature, but thermocouples degrade and fail frequently under the harsh conditions.

LumaSense thermal imaging solutions and pyrometers are made specifically to withstand the extremely harsh environments found in the steel industry. The cooled and purged instrument enclosures provide the highest level of protection.

For refractory or wall measurement, the MIKRON MCL640 Series's accuracy and over 300,000 points of measurement allow operators to detect the smallest refractory breaks before they cause costly downtime. LumaSense's FurnaceSpection system solution can be used for through-flame temperature measurements.

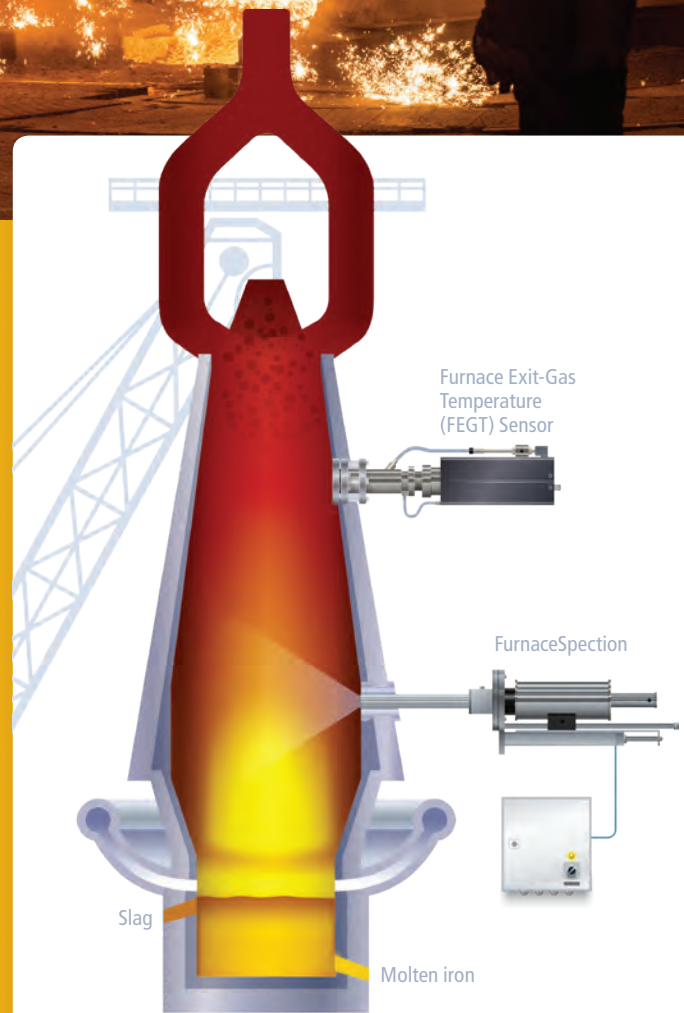

KEY PRODUCTS

Pyrometers: FEGT System, ISR 6-TV Advanced, IS 6 Advanced, IGA 6 Advanced, ISR 6 Advanced, IS 8 pro, etc.

Thermal Imagers: FurnaceSpection, BoilerSpection, MCL640, MCS640

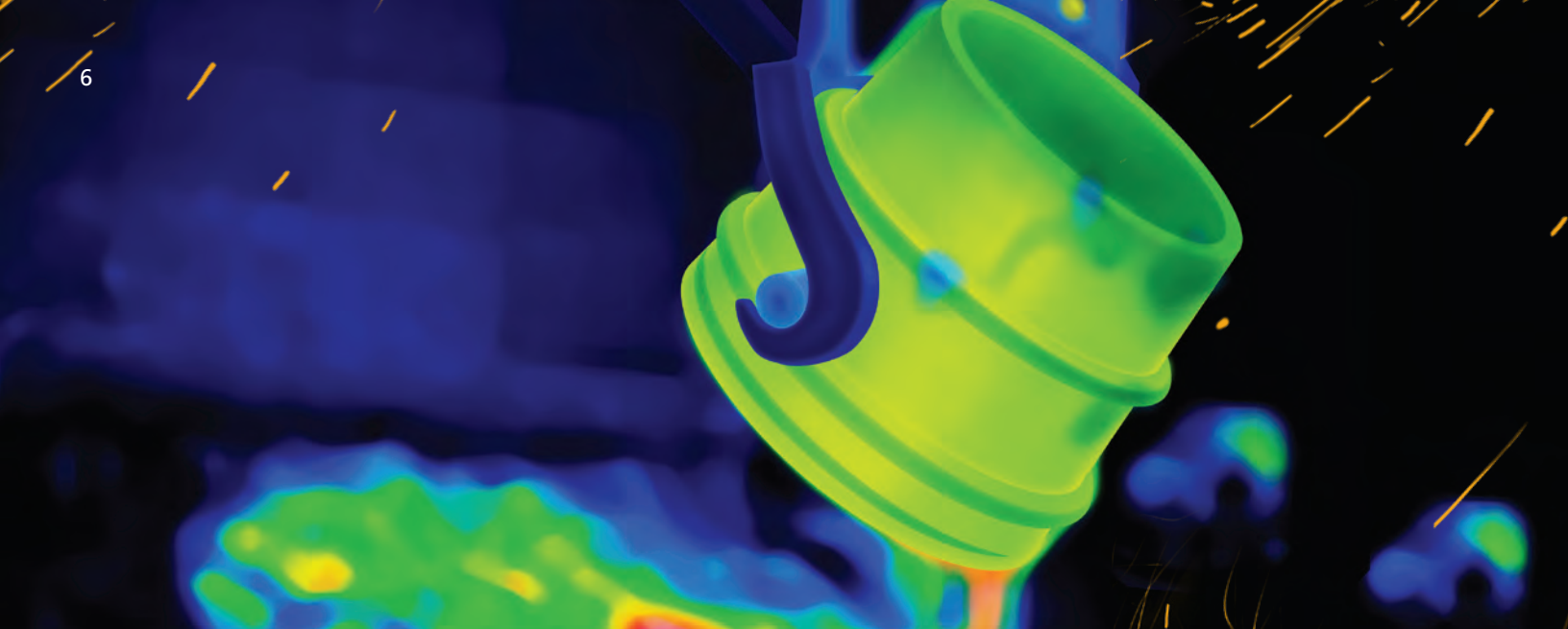

Ladles & torpedo cars

Ladles and torpedo car linings are made of refractory materials that are subjected to heavy strain and wear from filling and emptying of molten iron.

Ladle pre-heating is used to keep the refractory brick from cracking when the hot molten steel is poured into a ladle and also prevents the molten metal from hardening when it hits a cooler area of the refractory. Routine inspection of metal components help operators identify weak points in the lining and prevent damage.

Operators can mount LumaSense's 3.9 μm spectral response pyrometer on top of the preheat ladle lid to view through the flame and down to the bottom of the

refractory. This positioning provides accurate and reliable temperature measurements without the risk of burnout and can reduce ladle pre-heat time.

In addition, thermal imaging allows operators to detect hot spots with consistent monitoring and inspection of the exterior condition of a steel ladle. Operators can quickly determine if the ladle's refractory can be reused or should be replaced and reduce the possibility of molten metal breaking through a torpedo car.

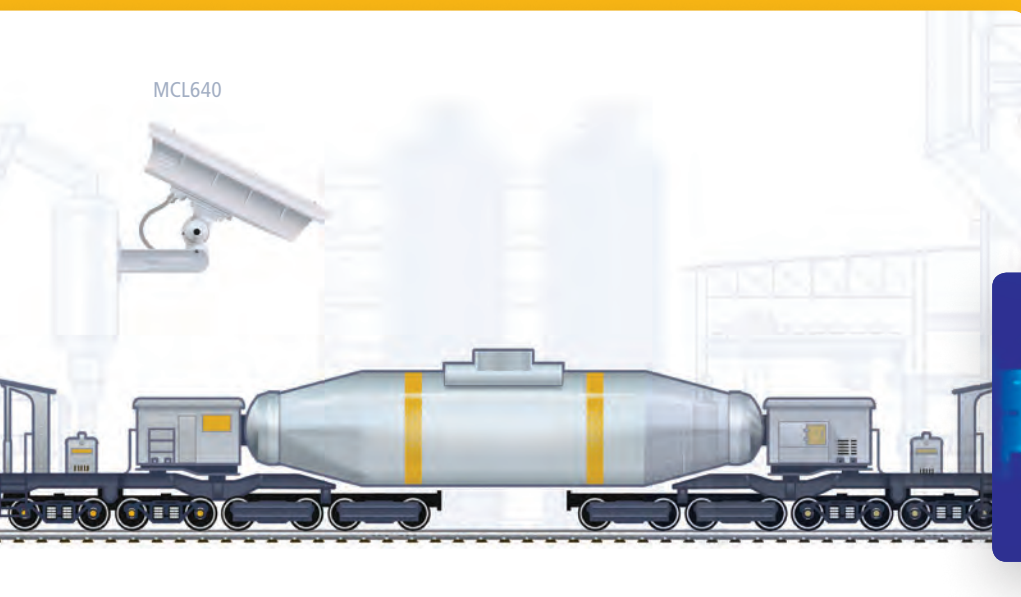

KEY PRODUCTS

Pyrometers: IPE 140/39.

Ladle Pre-heating: IGA 50-LO plus, IGA 8 pro

Thermal Imagers: MCL640 Series

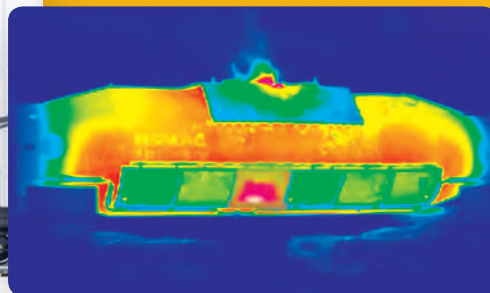

Hot forming

In hot forming applications such as forging, press forging, bending, and press hardening, correct forming and heat treatment temperatures are instrumental in meeting the specified quality requirements and achieving optimum properties of work pieces. In addition to precise temperature measurements, closed-loop process control and documentation of measured data are often required.

To minimize the systematic measuring errors that may be caused by external influences (e.g. surface variations, reflections), temperatures on metal surfaces should always be measured at the shortest possible wavelengths. LumaSense solutions include robust cooling jackets and protective enclosures designed to protect the instruments in harsh, high-temperature steel environments.

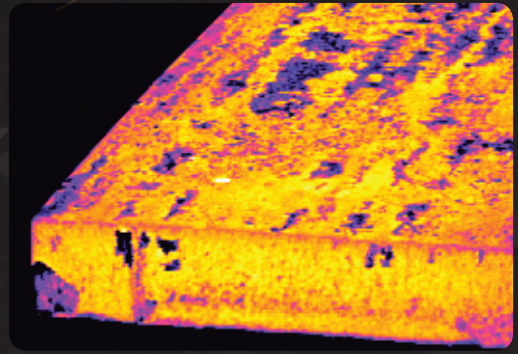

KEY PRODUCTS

Pyrometers: IS 8 pro, IGA 8 pro, IS 140, IGA 140, IS 50-LO plus, IS 320, IGA 320, IS 6 Advanced, IGA 6 Advanced, ISR 6, IGAR 6, TQCS Software

Thermal Imagers: MCS640

Continuous casting

Continuous casting is the process where the molten steel is cooled and solidified into billets or slabs.

The operator's challenge is to keep the steel within the channel and control the cooling rate.

Accurately measuring cooling requirements of slabs, billets, or blooms to ensure product uniformity and provide equipment operators with immediate temperature information is critical to the cooling process.

Using special protective hardware, LumaSense pyrometers and thermal imagers monitor the temperature as the molten metal pours down the mold. The temperature readings help the operators control the speed of the process and the amount of cooling sent through the mold and improves the quality of the slab and billets.

KEY PRODUCTS

Pyrometers: ISR 12-LO, ISQ 5-LO, IS 50/055-LO plus with SG-LO, IS 8 pro

Thermal Imagers: MCS640

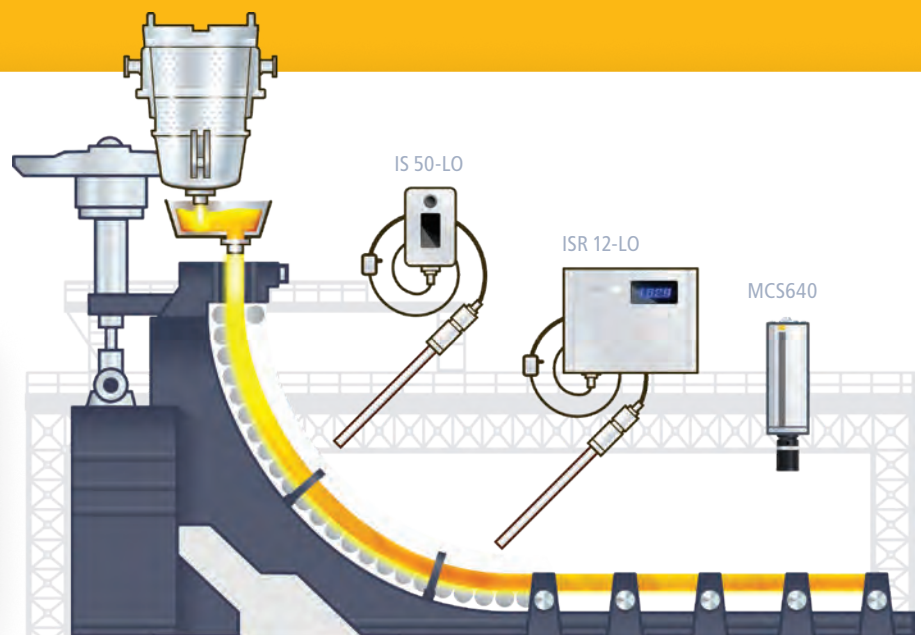
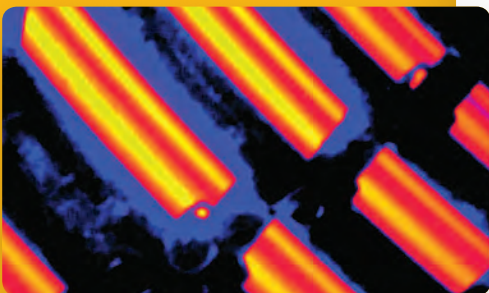

Casting

In casting application, correct temperatures of all process steps are instrumental in meeting the specified quality requirements and achieving optimum properties of end products. To minimize the measurement errors from external influences, temperatures should be measured with the shortest available wavelength. In very harsh environments, two color pyrometers are the best choice.

LumaSense pyrometers and thermal imagers accurately measure all relevant temperatures to establish a stable production process and allow operators to better control and influence parameters for best product quality. With single or two-color pyrometers and thermal imagers, all process steps can be monitored and recorded.

KEY PRODUCTS

Pyrometers: ISR 12-LO/GS, IS 8-GS pro, ISR 6 with line optics

Thermal Imagers: MCL640, MCS640

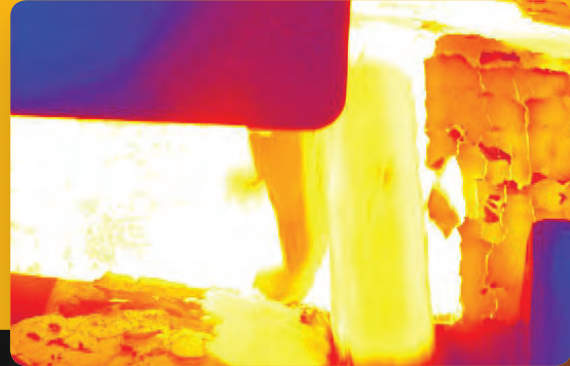

Slag detection & pouring stream measurements

When liquid steel is tapped from a basic oxygen (BOF) or electric arc (EAF) furnace, it is advantageous to minimize the quantity of slag carried over into the ladle. Measuring the average temperature of the pouring stream during the pour can be a challenge with the presence of slag and oxidation. Previously, temperature measurement was completed by visual observation of the tapping stream or using electromagnetic induction coils mounted onto the furnace. However, neither of these methods has proven to be entirely reliable. Thermocouple immersion probes can only be made in the crucibles or transfer ladles where the melt is stationary.

Thermal imagers provide a controlled field of view that is aimed at a specific region of the pour as it exits the furnace. Pyrometer solutions can monitor the pouring stream under varying widths and determine the average and maximum temperatures. The highly precise detectors in our process thermal imaging cameras and pyrometers measure the exact cast temperature, which is crucial for the quality of the cast product. Ratio (two-color) pyrometers are ideal for this process since pouring streams produce thin oxide films that vary from the emissivity of the cast material. Since they detect the emitted infrared radiation on two different wavelengths, the measurement becomes mainly independent of the emissivity.

KEY PRODUCTS

Pyrometers: ISR 12-LO/GS, IS 8-GS pro, ISR 6 Advanced with line optics

Thermal Imagers: MCS640



Rolling mills: slabs, bars, billets

Infrared sensors measure strip and sheet temperature so that rolling mill stands can be efficiently set to match the steel's temperature. Sensors can be used to detect the presence of hot metal and accurately time the roll stand operation.

Pyrometers can be used to measure the roll temperature as water cools the roll during the quenching process. Steam is an issue with this application, requiring special spectral responses to accurately measure system temperature.

LumaSense pyrometers and thermal imagers are ideal solutions to ensure uniform temperature and keep the slab within its working temperature range. They

can selectively control the quench zones so that only the higher temperature part of the slab is quenched to the maximum extent allowed, resulting in greater working time. Ratio pyrometers usually help to minimize the effect of steam interference.



KEY PRODUCTS

Pyrometers: IS 8 pro, ISR 12-LO, ISR 320, ISR 6 Advanced, IGAR 6 Advanced, IS 320, IS 140, IS 12, IS 12-S, IPE 140/39, etc.

Thermal Imagers: MCS640, FurnaceSpection

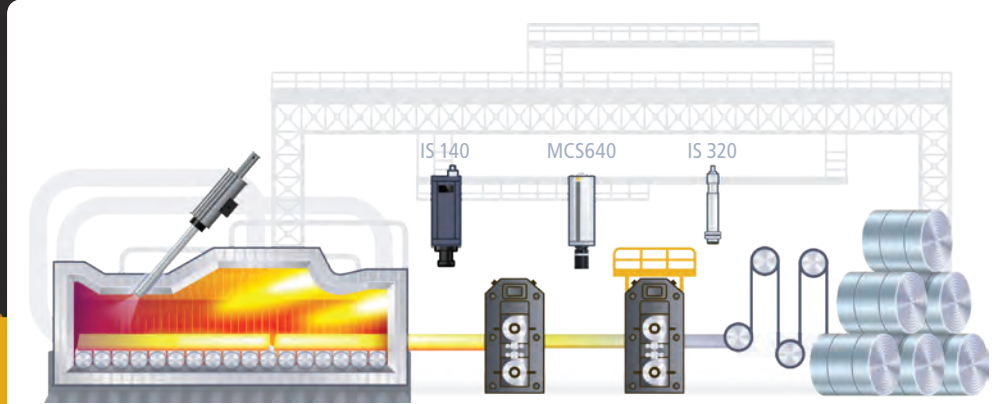

Burr detection

When cutting steel slabs, there is a flow of slag which may solidify as burrs on the underside of the slab. The removal of these burrs is critical and the deburring system may occasionally skip over the burrs which are sometimes extremely flat. Current visible systems have not been proven reliable for residual burr detection.

The use of the MIKRON MC320 Series thermal imaging system ensures residual burr detection after the slab-cutting process. It allows users to accurately detect temperature differences between slab and burrs through the use of high-resolution cameras.

KEY PRODUCTS

Thermal Imagers: MC320 Series

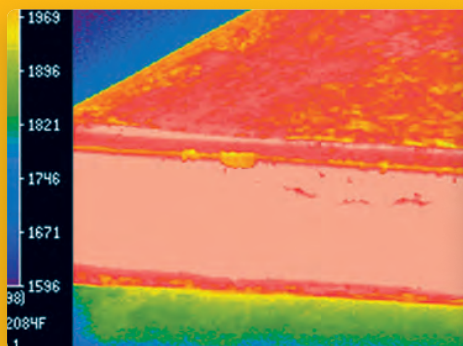

Annealing furnaces

Annealing is a controlled heating and then cooling process that changes the metal's characteristics.

It is often a relatively slow process requiring significant energy. Inaccurate temperature measurement, non-uniform ovens, or poorly sealed furnaces lead to added costs and reduced quality.

LumaSense pyrometers and thermal imagers can be used to accurately monitor both product temperature and

furnace temperature. Thermal imagers and multiple spot pyrometers are used to control uniformity inside furnaces with zone control. Use thermal imagers to investigate door seals and external insulation to find leaks and other sources of heat loss which negatively impact energy usage. LumaSense thermal imagers combine unparalleled accuracy and ease-of-use.

KEY PRODUCTS

Thermal Imagers: MCS640, FurnaceSpecion

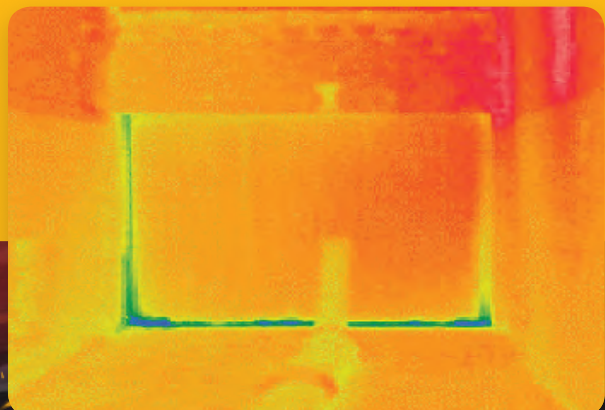

Additional applications



Global
Applications
Engineering

The LumaSense Global Applications Engineering team is staffed with Senior Engineers to help develop innovative solutions for customers worldwide.

Other steel-related applications we've developed a solution for:

- Coke quenching monitoring
- Bridge wall monitoring
- Gas burner cutting monitoring
- Roller surface overheating detection
- Wire forming monitoring
- Controlling cooling zone of slabs
- Tube welding
- Control of the sintering plant
- Control of the flare systems
- Reheat furnace
- Walking-beam furnace

Americas, Australia, & Asia

Headquarters Sales & Service
Santa Clara, CA
Phone +1 408 727 1600
Phone +1 800 631 0176 US TOLL-FREE
Fax: +1 408 727 1677

Europe, Middle East, Africa

Sales & Service
Frankfurt, Germany
Ph: +49 69 97373 0
Fax: +49 69 97373 167

Denmark

Innova Sales & Support Center
Ballerup, Denmark
Ph: +45 44 2001 00
Fax: +45 44 2001 01



France

Sales & Support Center
Erstein, France
Ph: +33 3 8898 9801
Fax: +33 3 8898 9732

India

Sales & Support Center
Mumbai, India
Ph: +91 22 67419203
Fax: +91 22 67419201

China

Sales & Support Center
Shanghai, China
Ph: +86 133 1182 7766
Ph: +86 21 5899 7915

www.lumasenseinc.com
LTI-Info@aei.com

© 2018 LumaSense Technologies, Inc.
All Rights Reserved. LumaSense Technologies, Inc. a subsidiary of Advanced Energy Industries, Inc.
LumaSense, MIKRON, IMPAC, LumaSpec, FurnaceSpec, and ThermalSpec are trademarks of
LumaSense Technologies, Inc. All information contained herein is provided for information only and is
subject to change without notice.

Steel Brochure-Letter-EN Rev. 01/22/2019