

VELA INDUSTRIAL

HYDRAULIC BARRIER FOR
INTENSIVE USE FOR BEAMS UP TO 7,5 METERS.



Fast and reliable hydraulic barrier!

- Hydraulic barrier designed for beam lengths up to 7000 mm. Double yoke beam carrier allows for 7500 mm widths.
- **SEA TOTAL QUALITY:** All main components are manufactured and tested in-house ensuring the highest of engineering standards.
- Hydraulic operation provides an extremely quiet, extremely robust system.
- Safety valves in both directions of travel allow for accurate adjustment of operating pressures.
- Key accessible manual release system in case of power failure.
- Steel casing processed with cataphoresis and finished in polyester powder coat.
- Stainless steel casings available.
- Hydraulic slow down at end of travel in both directions provides smooth and safe barrier operation.

manual release & safety valves

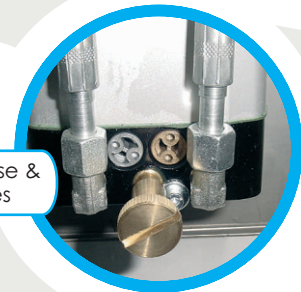

Smooth, safe, quiet and hard wearing!

- Designed for use on busy entrances with a high level of safety provided as standard.
- Barrier beams are spring counterbalanced to reduce loadings on the motor, extending the life of the barrier.
- Left and right hand cabinets available.
- Double arm arrangement provides an extremely strong beam carrier.
- Thermal overload built in to the motor to provide the highest level of protection.
- Internal non return lock valves secure the barrier in all positions.
- Operating speeds of 8 - 12 seconds.
- Up to 75% duty cycle means that the Vela Industrial barrier can cope with the busiest of installations.
- Foundation plates, adjustable and flexible fork supports available.

Double yoke

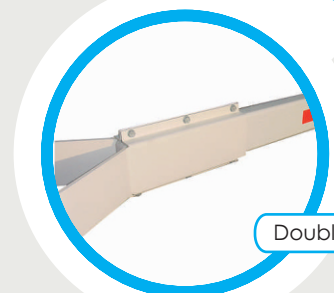

**When quality matters make sure it's SEA
the engineers' choice!**

SEA (UK) Limited.
Unit 6A Olton Wharf, Solihull,
West Midlands, B92 7RN
Birmingham Tel: 0121 706 9629
Birmingham Fax: 0121 764 5603
London Tel: 020 8360 8022
London Fax: 020 8364 2516

sales@seauk Ltd.com
www.seauk Ltd.com
www.seateam.com

VELA INDUSTRIAL

Specifications

VELA INDUSTRIAL

Supply Voltage	230Vac
Motor Power	230 W
Motor current	1.1 A
Opening speed	8 -12 sec
Frequency of use	75%
Thermal protect.	130° C
Operating temperature	-20°C + 55°C
Operator Weight (without metal yoke attachment)	73 Kgs
Oil quantity	1.5 lt
Max beam length	7.5 mtr
Protection class	IP55
Starting Capacitor	12.5 •uF

CONTROL BOARD Specification

Gate 1

- Management of a 230 Vac motor with or without limit switch.
- Automatic logic (4 modes), semiautomatic and step by step logics.
- Electronic slow down in opening and closing.
- Motor run time and pause open time regulation.
- Self-learning operating time for barrier with limits.
- Self-test on photocells.
- Self-diagnostic system.
- Encoder management for increased safety.
- Diagnostic Leds on all outputs/inputs.
- Extractable connectors for ease of installation.
- Integrated receiver compatible with radio transmitters SMART, HEADROLL and HEAD ECOPY series (800 users).
- Fully compatible with all SEA accessories.
- Compatible with most manufacturers of audio and video intercom equipment.
- Digital code pads.
- Card reader systems, stand alone and computer linked.
- Time clocks and hold open switches.
- Induction loop free entry, free exit and safety.
- Photocell free entry, free exit and safety.
- Patented rubber mechanical safety edges.
- Vehicle recognition systems.
- Biometric identification systems.

Dimensions in (mm)

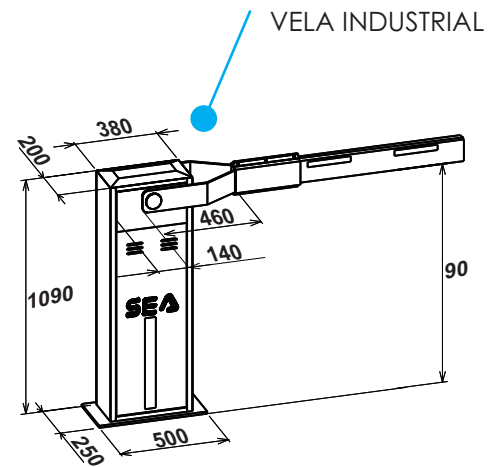

Opening time of the barrier depending on beam length

ARM LENGTH	5.0	6.0	7.0	7.5
VELA INDUSTRIAL	8.0 sec.	9.5 sec.	11.0 sec.	12.0 sec.

Beam length

VELA INDUSTRIAL	4.5 mtr	5.5 mtr	6.5 mtr	7.0 mtr
-----------------	---------	---------	---------	---------

Accessories.

Loop detectors / Photocells / Key pads / Card readers / Transmitters & receivers / Telephone entry systems / Audio and video intercom systems wired and wireless.

Vehicle recognition systems / Biometric recognition systems / Patented rubber mechanical safety edge / Time clocks / Hold open switches.

