



SS2100 ACETYLENE MEASUREMENT

AT THE INLET OF FRONT END ACETYLENE CONVERTERS

Product Code 56311

KEY FEATURES

- Extremely fast analysis time – 1 second updates possible
- No consumables – Low Cost of Ownership
- No routine service needed
- High resolution laser-based measurement eliminates errors due to interferences
- Reliable Tunable Diode Laser lasts years

Ethylene is one of the most important feedstocks for the petrochemical industry. Since it is used in the manufacturing of a wide range of compounds, Ethylene has very stringent purity specifications. One of the more important steps in purifying the ethylene is removing the acetylene. There are 4 common methods of Acetylene removal in Ethylene process which have evolved over the years:

- Solvent Extraction using Dimethyl Formamide (DMF)
- Cracked Gas Train or Raw Gas Catalytic Hydrogenation
- Back End Catalytic Hydrogenation
- Front End Catalytic Hydrogenation

ACETYLENE CONVERTER UNIT

The Acetylene Converter Unit consists of a series of reactors (Fig. 1) or a single vessel with multiple beds of catalyst (Fig. 2) which reacts the Acetylene with Hydrogen to form Ethylene. The reactor or bed will reduce the

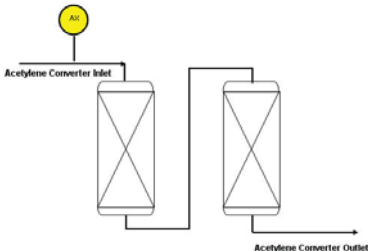

Figure 1: Typical 2-Vessel Acetylene Converter Unit

amount of Acetylene from several thousand ppm down to several hundred ppm. The second reactor or bed reduces the Acetylene further to the low ppm and even ppb levels. Front End Acetylene Converters are typically located upstream of the De-Methanizer on a mixture of gases that includes a large excess of Hydrogen, typically 10 – 35 Mole%. Depending on the process, the mixture may contain the C2's and lighter gases, or the C3's and lighter. See the Typical Stream Composition table on page 4.

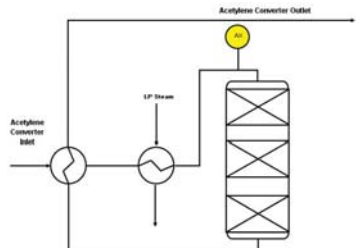

Figure 2: Typical Multi bed Vessel Acetylene Converter Unit

CRITICAL CONTROL OF ACETYLENE

It is critical that the Acetylene be brought down to the proper levels as it exits the final reactor; otherwise, any Acetylene present will follow the Ethylene all the way to the final product stream. But if the unit operates too aggressively, it could hydrogenate some of the Ethylene into Ethane. Measurements are made at the inlet of the Acetylene Converter Unit for feed-forward control strategies.

TRADITIONAL MEASUREMENT

SOLUTIONS On-line gas chromatographs have been the traditional method for monitoring the levels of Acetylene in the process streams. Unfortunately, even with the latest in chromatography techniques, the analysis can take 3-6 minutes between measurement updates. Due to the very short residence times in the reactors, this delay in measurements can easily lead to excursions in concentrations before it is detected. Also, gas chromatographs consume carrier and flame fuel cylinder gases, as well as requiring hydrocarbon-free air for flame ionization detectors, so the consumable costs of GC's are high.

SPECTRASENSORS' SOLUTION

The SpectraSensors SS2100 is the ideal solution for this challenging application. The use of Tunable Diode Laser technology means that analysis results can be updated every second if desired. Furthermore, the high resolution which is inherent to TDL technology eliminates errors due to interferences that have hampered other spectrometric approaches. There are no consumables required for Acetylene analysis, so cost of ownership is low.



SS2100 Acetylene Analyzer

SPECIFICATIONS

Application Data

Target Components	Acetylene in Front End Acetylene Converter - Inlet
Typical Measurement Ranges	0-5000 (or greater)*
Typical Precision	±2% of Full Scale*
Measurement Response Time	1 to ~60 seconds*
Principle of Measurement	Tunable Diode Laser Absorption Spectroscopy Non-differential
Environmental Temperature Range	-20° to 50° C (-4° to 122° F) -10° to 60° C (14° to 140° F) <i>optional</i>
Sample Inlet Pressure	70kPag (10 PSIG) typical 210kPag (30 PSIG) maximum
Sample Cell Temperature Range	Maintain at 50° C ±2° C
Maximum Cell Pressure	70kPag (10 PSIG)
Sample Flow Rate	1-2 L/min (2.1 to 4.2 scfh)*
Recommended Validation	Certified blend of C ₂ H ₂ in Nitrogen balance



Electrical Data

Power	100-240 VAC, 50-60 Hz standard
Max Current	Controller: 1 A @ 120 VAC
Controller to Cell Cable Length	1m standard (3m, 5m & 10m available optionally)
Communication	Current Loop Output 4-20 mA Isolated, 1200 ohms @ 24 VDC max load. Serial: ASCII Text RS232C standard, Modbus RS232C
Digital Outputs	Four (4) 12 VDC for valve operations: Scrubber (if required), Process/Val, Val 1, Val 2 5 SPDT (Form C) Dry Contacts: Common Fault, Val 1 Active, Val 2 Active, Val Fail, One user assignable DO to standard alarms
LCD Display	Concentration, Cell Pressure and Temperature, Diagnostic Data

Physical

Controller Enclosure	NEMA 4X – 304 stainless steel <i>standard</i>
Controller Dimensions	343 mm H x 305 mm W x 165 mm D (13.5" H x 12" W x 6 7/16" D)*
Weight Approximately	13.1 Kg (28.6 lbs)*
Sample Cell Dimensions	0.8m cell for ranges >100, 438 mm H x 108 mm W (17-1/4"H x 4-1/4"W)
Sample Cell Construction	316L Series Polished Stainless Steel Standard
Number of Sample Cells	1 (Single Channel SS2100) or 2 (Dual Channel SS2100)
Dimensions with Sample System	1678 mm H x 613 mm W x 427 mm D (66" H x 24-1/8" W x 16-13/16" D)
Weight with Sample System	68 Kg (150lbs)

Area Classification

Certification	CSA Certified for Class I, Div. 2, Groups ABCD T3C  II 2G Ex d IIB+H2 T5; Tamb : -20 ÷ +60 °C
---------------	---

* Application specific; consult factory.

TYPICAL ETHYLENE PROCESS WITH FRONT END ACETYLENE CONVERTER

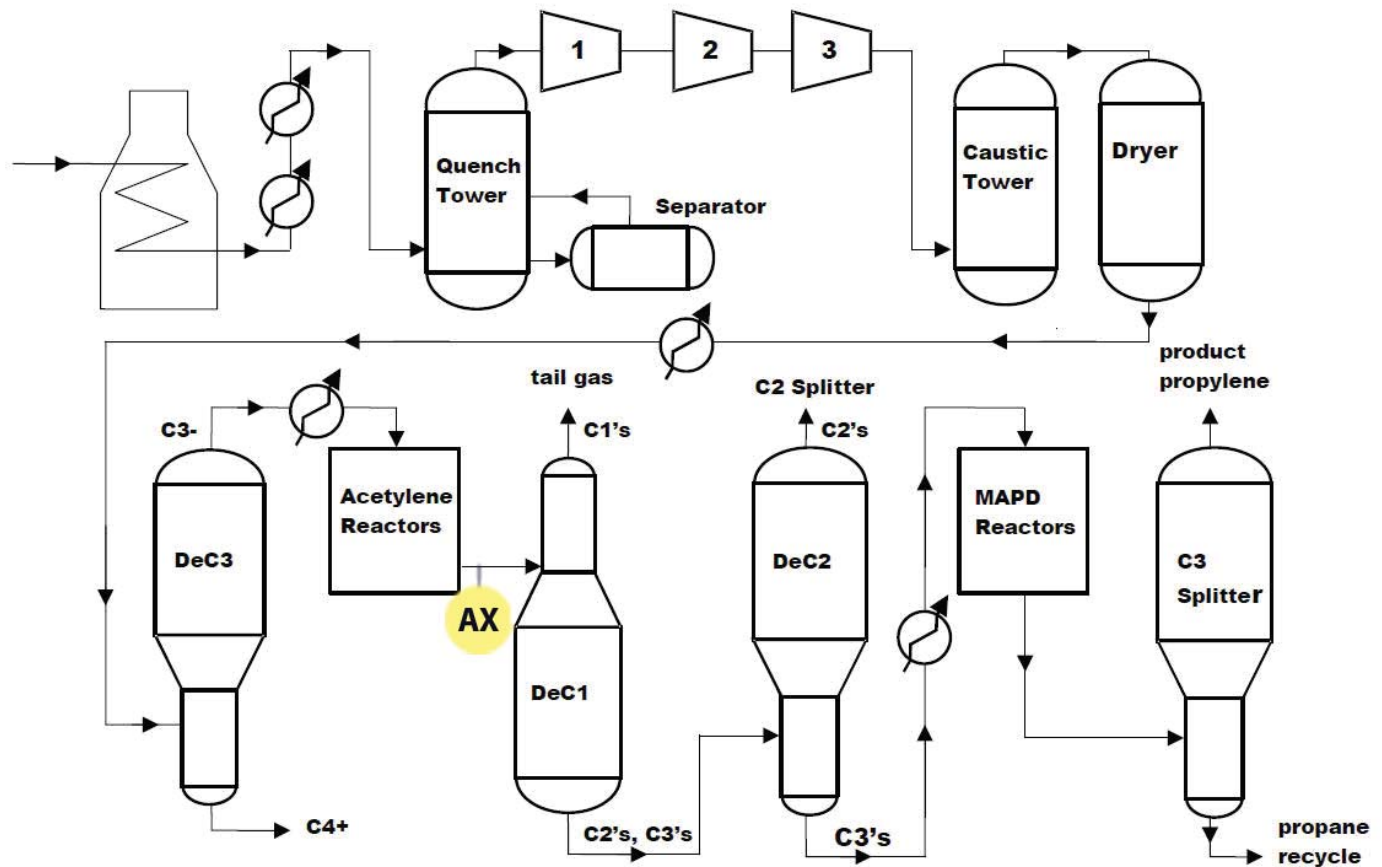

Location of acetylene reactors in a qualitative depiction of a front end depropanizer configuration

ANALYZER

The Analyzer consists of the electronic controller, cell, and 1m long interconnecting cable (standard). Interconnecting cable lengths of 3m, 5m and 10m are also available for mounting the controller remotely, for example, with the controller mounted inside an analyzer shelter and the cell and sample system outside the shelter. The sample conditioning system and/or cell enclosure must maintain the sample and cell at a constant temperature (generally 50°C +/- 0.2°C) that is above the hydrocarbon and moisture dew points of the process stream. The sample flow, sample pressure, and temperature specifications listed above must be maintained at all times. Any departure from these specifications must be approved by SpectraSensors.

Select the measured range desired. Other ranges are available by special order.

TYPICAL STREAM COMPOSITION FOR FRONT END CONVERTERS AT THE INLET:

Component	Unit	C ₂ & Lighter	C ₃ & Lighter	Min. for Application	Max. for Application
Acetylene (C ₂ H ₂)	ppmv	1500 - 5000	1500 - 5000	0	5000
Ethylene (C ₂ H ₄)	Mole %	34.0	32.5	25	90
Ethane (C ₂ H ₆)	Mole %	22.0	5.5	0	40
Hydrogen (H ₂)	Mole %	30.0	12.0	0	40
Methane (CH ₄)	Mole %	13.6	29.5	0	40
Propane (C ₃ H ₈)	Mole %	0	0.8	0	1
Propylene (C ₂ H ₆)	Mole %	0.08	19.0	0	25
Propadiene (C ₃ H ₄)	Mole %	0	0.3	0	0.5
Methyl Acetylene (Propyne C ₃ H ₄)	Mole %	0	0.3	0	0.5
Carbon Monoxide (CO)	ppmv	200	200	0	1000
Carbon Dioxide (CO ₂)	ppmv	< 1.0	< 1.0	0	1000
Total	Mole %	100			

The background stream composition must be specified for proper calibration and measurement performance. Specify the Normal composition, along with the minimum and maximum expected values for each component, especially acetylene the measured component. Other stream compositions may be allowable with approval from SpectraSensors.

RELAY CONTROL AND COMMUNICATIONS

All SS2100 Process Analyzers are supplied with 9 relays:

- o Four (4) are 12 VDC powered and provided for driving switching valves associated with Process, Validation 1 and Validation 2 and a scrubber (for differential systems only).
- o Five (5) SPDT (Form C) dry contact digital outputs are provided for common fault, Val 1 active, Val 2 Active, Validation Fail, and one (1) user-assignable DO to any standard alarm, such as high concentration, high cell pressure, low cell temperature, high cell temperature, low sample flow, etc. depending on the application.

Data Output is via 4-20 mA Isolated Analog Output.

Serial Communication via Modbus protocol is provided. See Modbus specifications for details.

MEASUREMENT SOLUTION

Proper sample conditioning is essential to an accurate and reliable measurement. SpectraSensors provides standard and custom engineered Measurement Solutions for all applications. Standard features include:

Inlet Pressure Relief Valve	Automatic Valve for Validation Gases
Inlet and Outlet Shut-off Valves	Cell Flow Rotameter and Control Valve
Sample Filter	Outlet Pressure Gauge
Sample Bypass Pressure Gauge	Cell Outlet Non-return Valve
Bypass Flow Rotameter and Control Valve	

VALIDATION

Validation is done with a certified blend of Acetylene in a background of Nitrogen, typically at a concentration in the middle of the measured range.