



SS2100 CARBON DIOXIDE IN CAUSTIC WASH TOWER INLETS

Product Code 56203

KEY FEATURES

- Extremely fast analysis time -1 second updates possible
- No consumables – Low Cost of Ownership
- No routine service needed
- High resolution laser-based measurement eliminates errors due to interferences
- Reliable Tunable Diode Laser lasts years

In Ethylene production one of the most important steps is removal of Hydrogen Sulfide and Carbon Dioxide from the process stream. Both H₂S and CO₂ are poisons to polymerization catalysts, and the allowable levels of both components are less than 5 ppmw in polymer grade Ethylene.

CAUSTIC WASH TOWER

Hydrogen Sulfide is required in Ethylene cracking furnaces to passivate the coil metallurgy, and also to limit the formation of CO₂ and CO. Any CO₂ entering the furnaces with the feedstock, CO₂ formed by the water shift reaction and CO₂ formed by decoking must be removed in the Caustic Wash Tower. CO₂ and H₂S are removed in the Caustic Wash Tower (Fig. 1) which is typically located after the third stage of compression on the cracked gas. The acid gases are absorbed in a dilute caustic solution.

CRITICAL CONTROL OF CARBON DIOXIDE

As Carbon Dioxide and H₂S concentrations can change depending on the feedstock and operating conditions of the process, the loading on the Caustic Wash Tower is highly variable. Measurement of CO₂ at the Caustic Wash Tower Inlet is critical to the unit caustic control.

TRADITIONAL MEASUREMENT SOLUTIONS

On-line gas chromatographs have been the traditional method for monitoring the levels of CO₂ in cracked gas streams. Unfortunately, even with the latest in chromatography techniques, the analysis can take 3-6 minutes between measurement updates. Due to rapid changes in the acid gas concentration, this delay may not be acceptable. Also, gas chromatographs consume carrier and flame fuel cylinder gases, as well as requiring hydrocarbon-free air for flame ionization detectors, so the consumable costs of GC's are high.

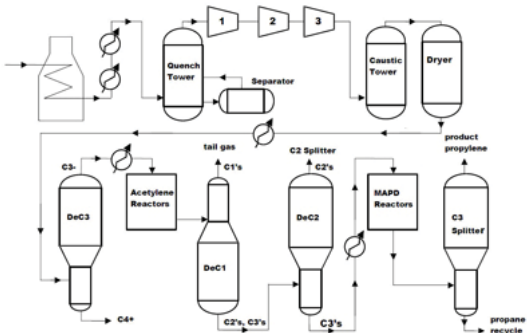

Figure 1. Location of acetylene reactors in a qualitative depiction of a front-end depropanizer configuration.

Spectroscopic methods using broadband light sources and narrow band pass filters are prone to interferences from changing background concentrations.

SPECTRASENSORS' SOLUTION

The SpectraSensors SS2100 offers a new solution to this control measurement. The use of Tunable Diode Laser technology means that analysis results can be updated every second if desired. Furthermore, the high resolution that is inherent to TDL technology eliminates errors due to interferences that have hampered other spectrometric approaches. There are no consumables required for CO₂ analysis at normal concentrations, so cost of ownership is low.

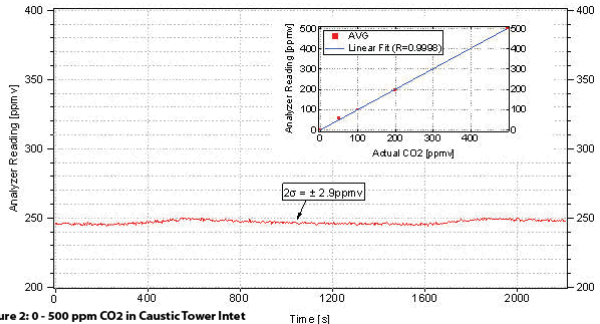

Figure 2: 0 - 500 ppm CO₂ in Caustic Tower Intet



SS2100 Carbon Dioxide Analyzer



SPECIFICATIONS

Application Data

Target Components	CO ₂ in Caustic Wash Tower Feed
Typical Measurement Ranges	0-500ppm*
Typical Precision	±2% of Full Scale
Measurement Response Time	1 to ~60 seconds*
Principle of Measurement	Tunable Diode Laser Absorption Spectroscopy Non-differential
Environmental Temperature Range	-20° to 50° C (-4° to 122° F) -10° to 60° C (14° to 140° F) <i>optional</i>
Sample Inlet Pressure	70kPag (10 PSIG) typical 210kPag (30 PSIG) maximum
Sample Cell Temperature Range	Maintain at 50° C ±2° C
Maximum Cell Pressure	70kPag (10 PSIG)
Sample Flow Rate	3-4 L/min (6.4 to 8.5 scfh)*
Recommended Validation	Certified blend of CO ₂ in Nitrogen balance

Electrical Data

Power	100-240 VAC, 50-60 Hz standard
Max Current	Controller: 1 A @ 120 VAC
Controller to Cell Cable Length	1m standard (3m, 5m & 10m available optionally)
Communication	Current Loop Output 4-20 mA Isolated, 1200 ohms @ 24 VDC max load. Serial: ASCII Text RS232C standard, Modbus RS232C
Digital Outputs	Four (4) 12 VDC for valve operations: Scrubber (if required), Process/Val, Val 1, Val 2 5 SPDT (Form C) Dry Contacts: Common Fault, Val 1 Active, Val 2 Active, Val Fail, One user assignable DO to standard alarms
LCD Display	Concentration, Cell Pressure and Temperature, Diagnostic Data

Physical

Controller Enclosure	NEMA 4X – 304 stainless steel <i>standard</i>
Controller Dimensions	343 mm H x 305 mm W x 165 mm D (13.5" H x 12" W x 6 7/16" D)*
Weight Approximately	13.1 Kg (28.6 lbs)*
Sample Cell Dimensions	8m Herriott cell, 559 mm H x 127 mm W (22"H x 5"W)
Sample Cell Construction	316L Series Polished Stainless Steel Standard
Number of Sample Cells	1 (Single Channel SS2100) or 2 (Dual Channel SS2100)
Dimensions with Sample System	1678 mm H x 613 mm W x 427 mm D (66" H x 24-1/8" W x 16-13/16" D)
Weight with Sample System	68 Kg (150lbs)

Area Classification

Certification	CSA Certified for Class I, Div. 2, Groups ABCD T3C  II 2G Ex d IIB+H2 T5; Tamb : -20 ÷ +60 °C
---------------	---

* Application specific; consult factory.

ANALYZER

The Analyzer consists of the electronic controller, cell, and 1m long interconnecting cable (standard). Interconnecting cable lengths of 3m, 5m and 10m are also available for mounting the controller remotely, for example, with the controller mounted inside an analyzer shelter and the cell and sample system outside the shelter. The sample conditioning system and/or cell enclosure must maintain the sample and cell at a constant temperature (generally 50°C +/- 0.2°C) that is above the hydrocarbon and moisture dew points of the process stream. The sample flow, sample pressure, and temperature specifications listed above must be maintained at all times. Any departure from these specifications must be approved by SpectraSensors.

TYPICAL STREAM COMPOSITION

Component	Unit	Typical Concentration	Min. for Application	Max. for Application
Carbon Dioxide (CO ₂)	ppmv	200	10	500
Hydrogen Sulfide (H ₂ S)	ppmv	500	0	1000
Hydrogen (H ₂)	Mole %	25	15	30
Methane (CH ₄)	Mole %	20	10	30
Ethane (C ₂ H ₆)	Mole %	15	10	30
Ethylene (C ₂ H ₄)	Mole %	25	20	40
Acetylene (C ₂ H ₂)	Mole %	0.3	0	0.5
Propylene (C ₃ H ₆)	Mole %	7.5	0	15
Propane (C ₃ H ₈)	Mole %	7.5	0	15
Methyl Acetylene (Propyne C ₃ H ₄)	Mole %	0.03	0	0.1
Propadiene (C ₃ H ₄)	Mole %	0.02	0	0.1
Carbon Monoxide (CO)	Mole %	0.05	0	0.1
Butanes	Mole %	0.05	0	0.1
Butenes	Mole %	0.3	0	0.5
1,3-Butadiene	Mole %	0.5	0	1
C ₅ +	Mole %	0.1	0	0.5
Total	Mole %	100		

The background stream composition must be specified for proper calibration and measurement performance. Specify the Normal composition, along with the minimum and maximum expected values for each component, especially CO₂, the measured component. Other stream compositions may be allowable with approval from SpectraSensors.

RELAY CONTROL AND COMMUNICATIONS

All SS2100 Process Analyzers are supplied with 9 relays:

- o Four (4) are 12 VDC powered and provided for driving switching valves associated with Process, Validation 1 and Validation 2 and a scrubber (for differential systems only).
- o Five (5) SPDT (Form C) dry contact digital outputs are provided for common fault, Val 1 active, Val 2 Active, Validation Fail, and one (1) user-assignable DO to any standard alarm, such as high concentration, high cell pressure, low cell temperature, high cell temperature, low sample flow, etc. depending on the application.

Data Output is via 4-20 mA Isolated Analog Output.

Serial Communication via Modbus protocol is provided. See Modbus specifications for details.

MEASUREMENT SOLUTION

Proper sample conditioning is essential to an accurate and reliable measurement. SpectraSensors provides standard and custom engineered Measurement Solutions for all applications. Standard features include:

Inlet Pressure Relief Valve	Automatic Valve for Validation Gases
Inlet and Outlet Shut-off Valves	Cell Flow Rotameter and Control Valve
Sample Filter	Outlet Pressure Gauge
Sample Bypass Pressure Gauge	Cell Outlet Non-return Valve
Bypass Flow Rotameter and Control Valve	

VALIDATION

Validation is done with a certified blend of Carbon Dioxide in a background of Nitrogen, typically at a concentration in the middle of the measured range.