



Powered By

FANUC

Grigory Belosky
Sales Director

OPTION 1



Product infeed
conveyor

1x FANUC M710 robot

1x palletising position
(manually positioned
and removed by the
operator)

Auto interlayer
positioning

E-cabinet with HMI

Infeed conveyor

Frame on a platform

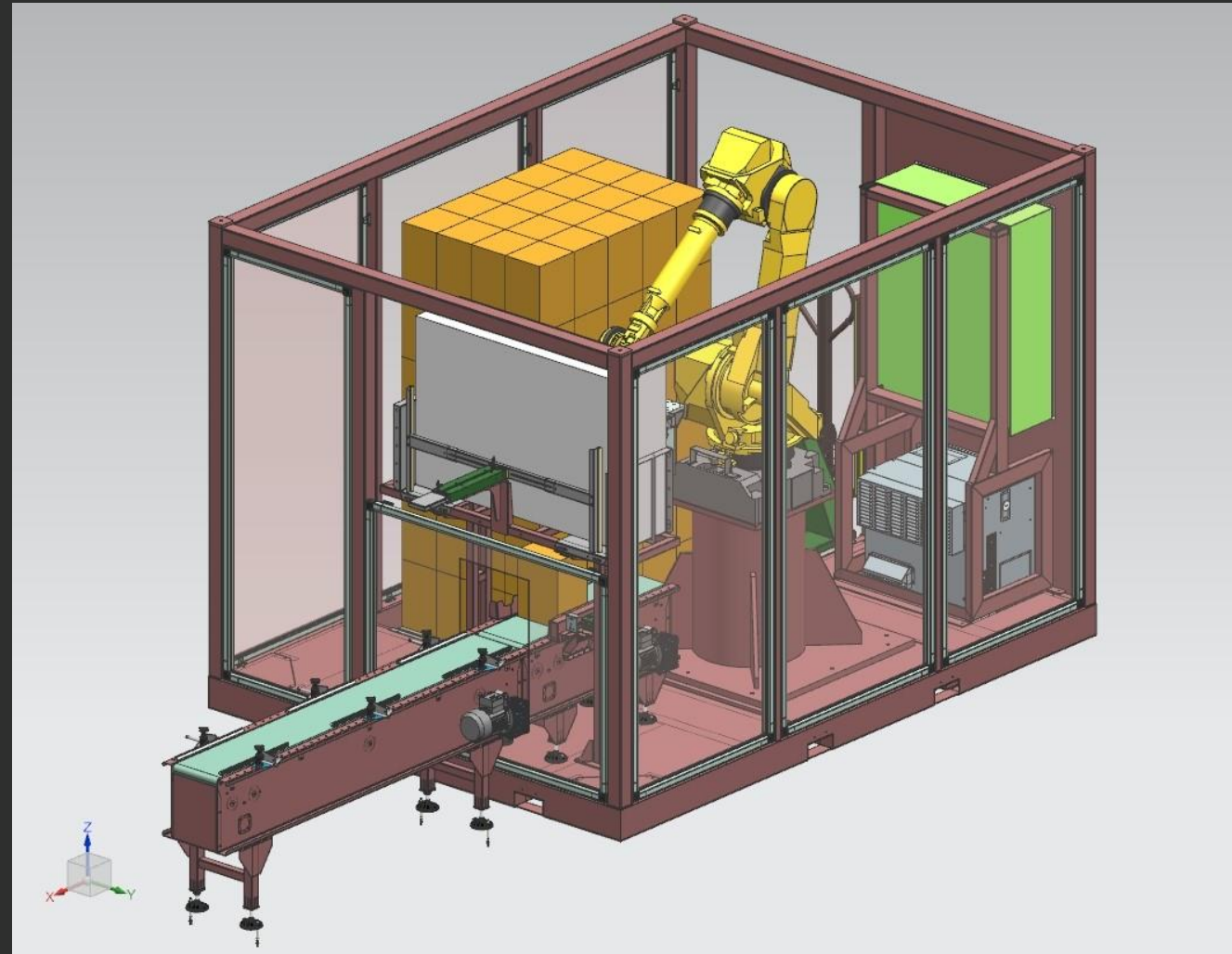

OPTION 1

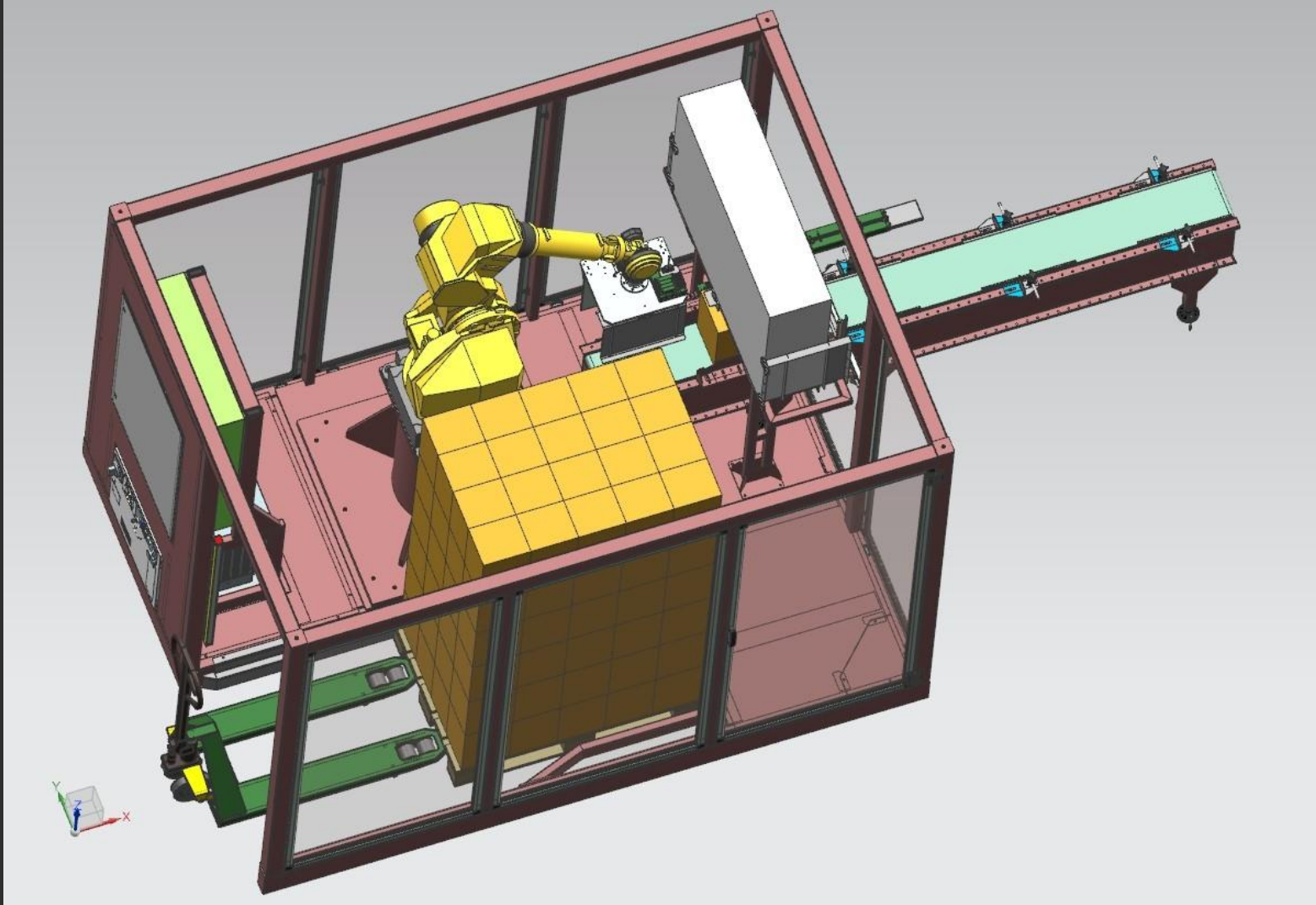

OPTION 1



Product infeed
conveyor with Print &
Apply system +
Barcode scanner

Integration with SAP

Infeed reject conveyor

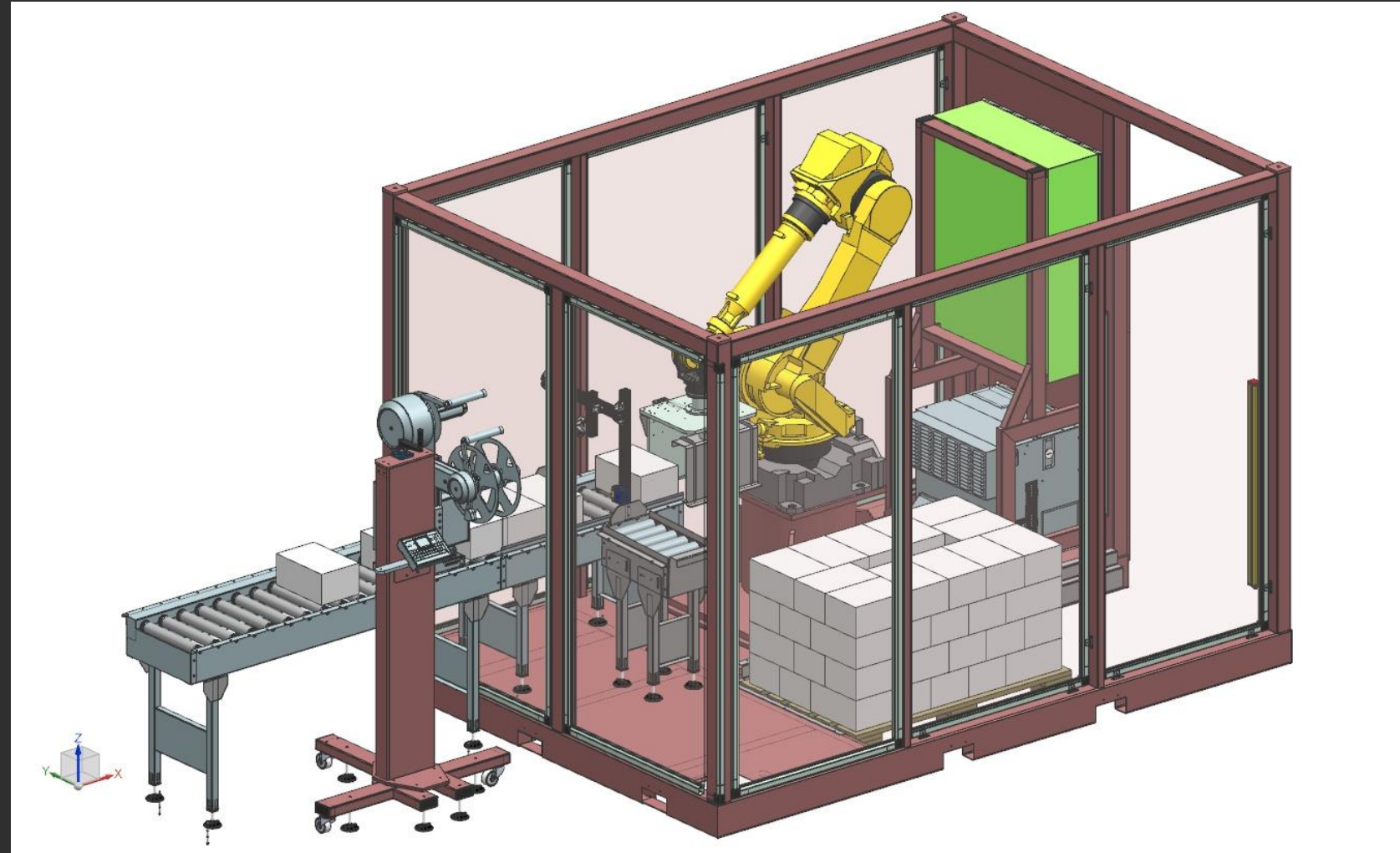

OPTION 2



2x palletising positions
for continuous
operation

Pallets manually
positioned and
removed by the
operator

Product infeed
conveyor with
collation

1x FANUC M710 robot

Auto interlayer
positioning

E-cabinet with HMI

Infeed conveyor

Frame on a platform

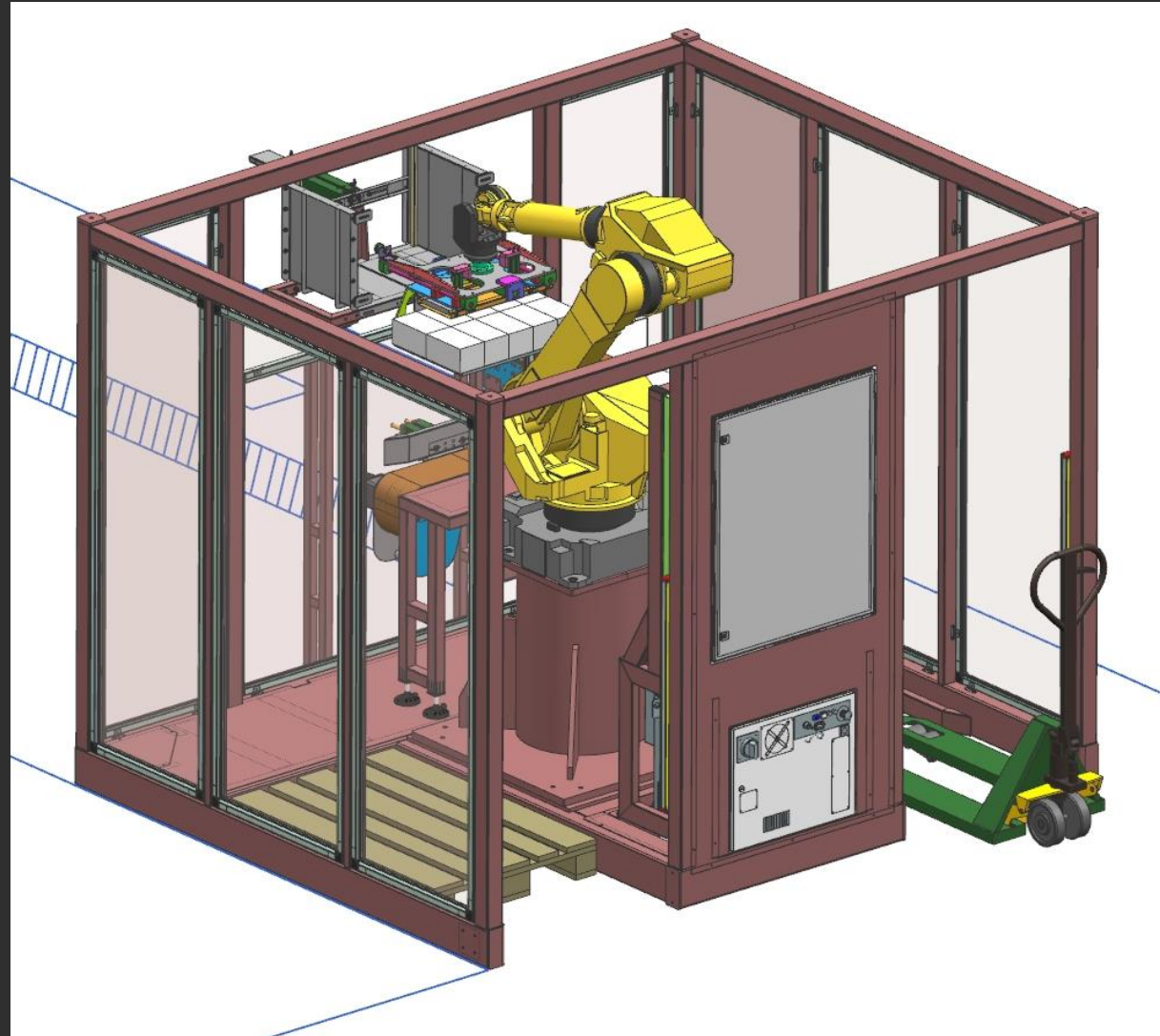

OPTION 2

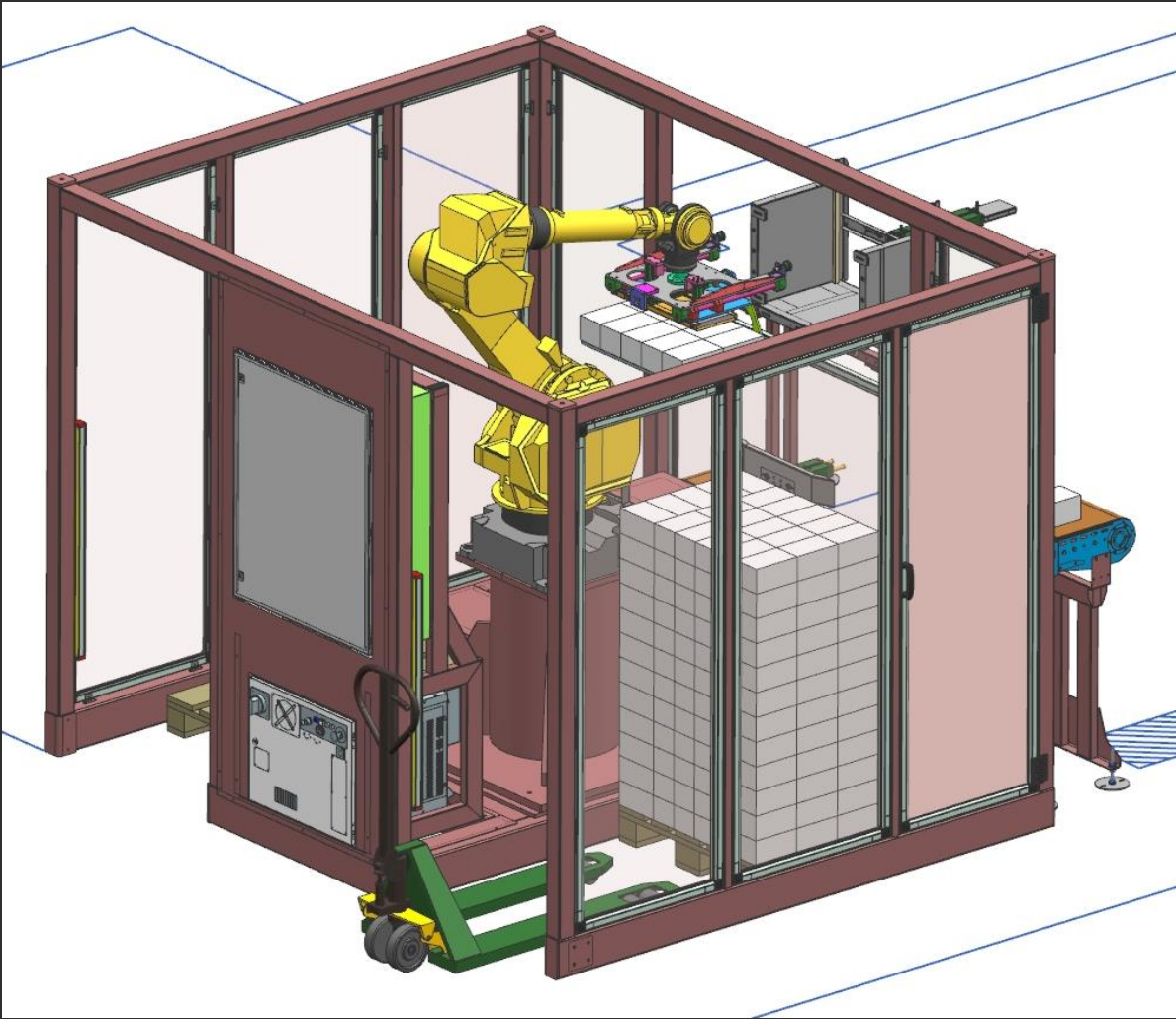

OPTION 3



Automatic pallet
de-stacker

Product infeed
conveyor with
collation

1x FANUC M710 robot

Auto interlayer
positioning

E-cabinet with HMI

Infeed conveyor with
pattern collation

Frame on a platform

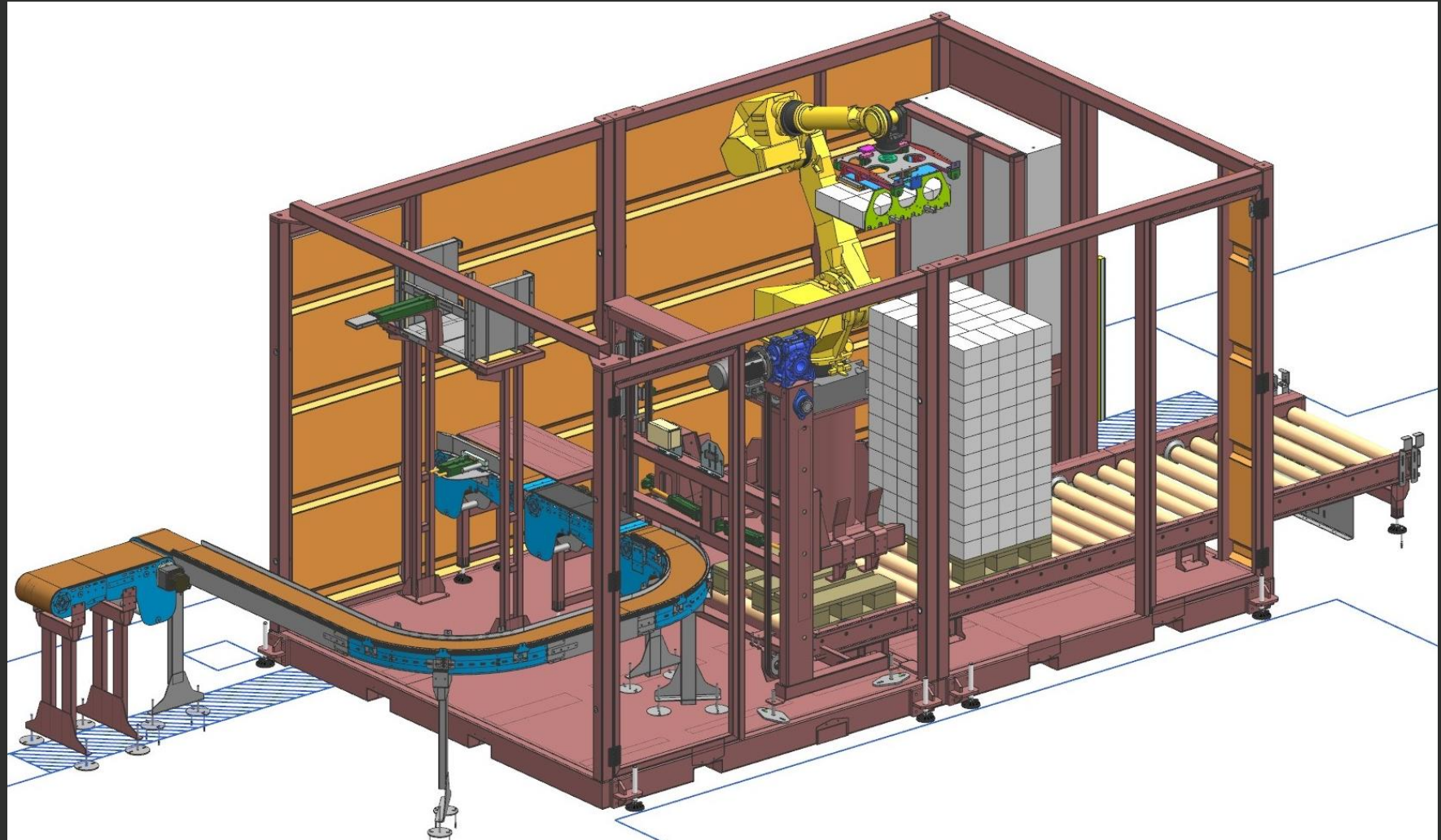

OPTION 3

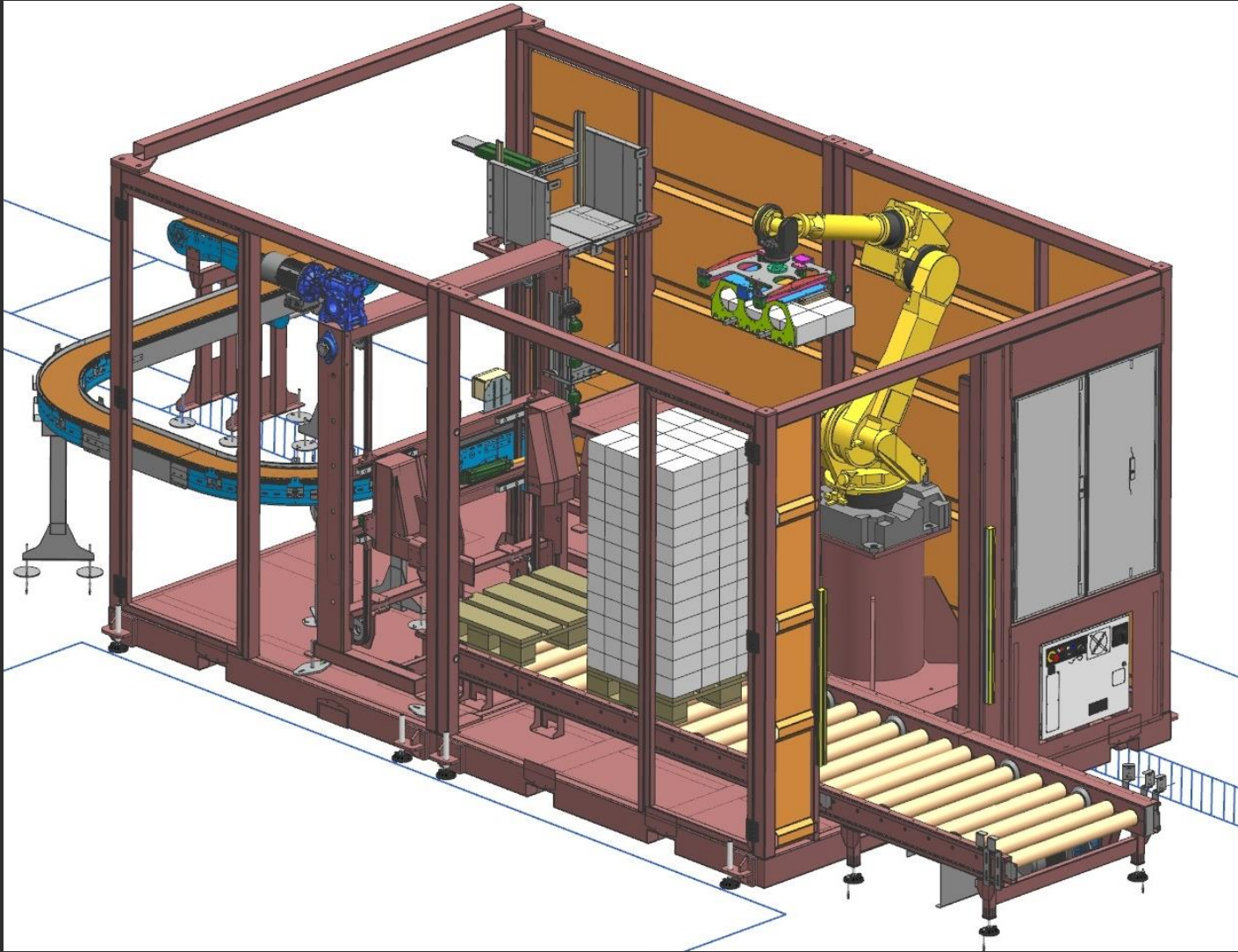

OPTION 4

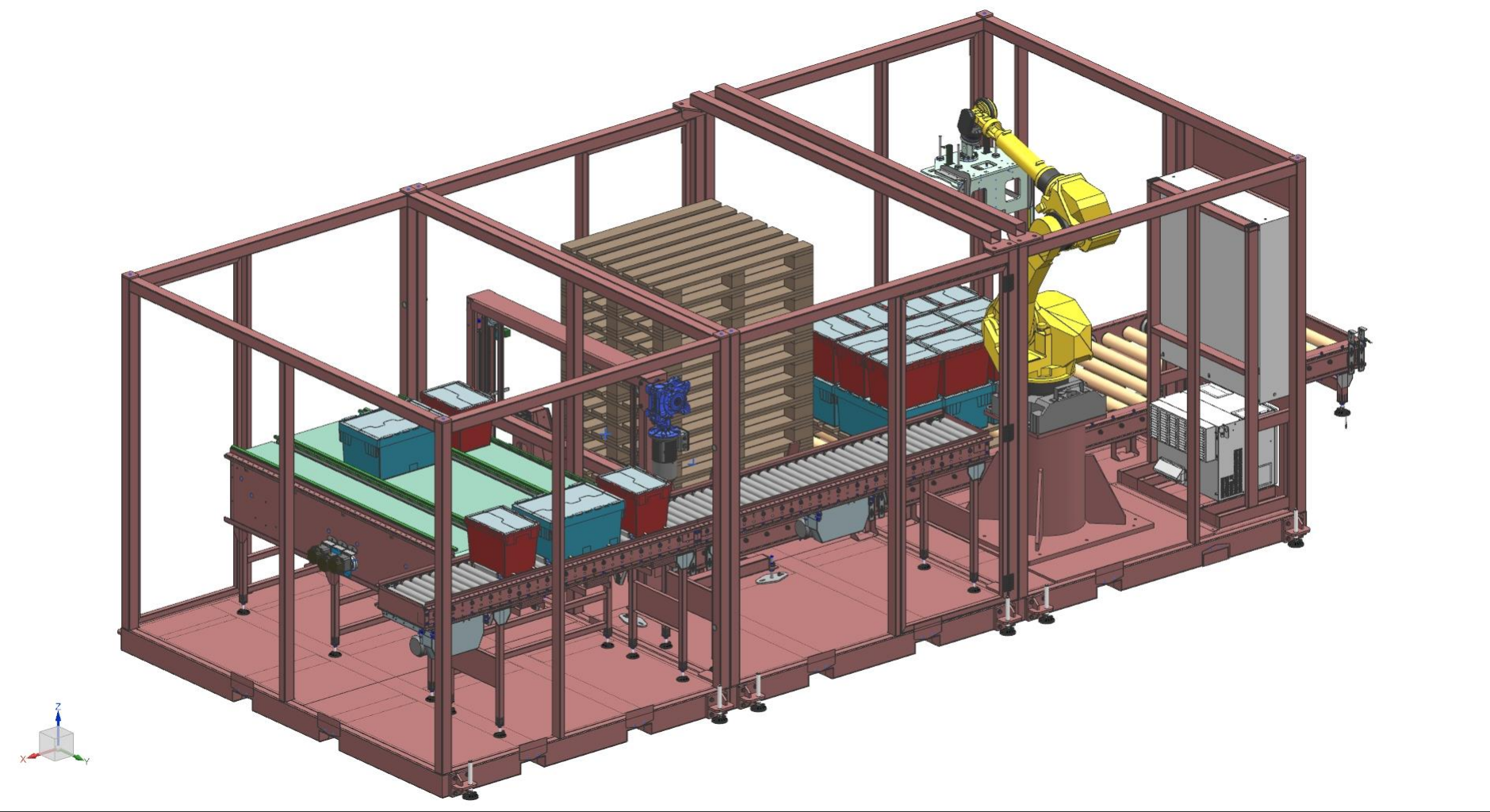

OPTION 4

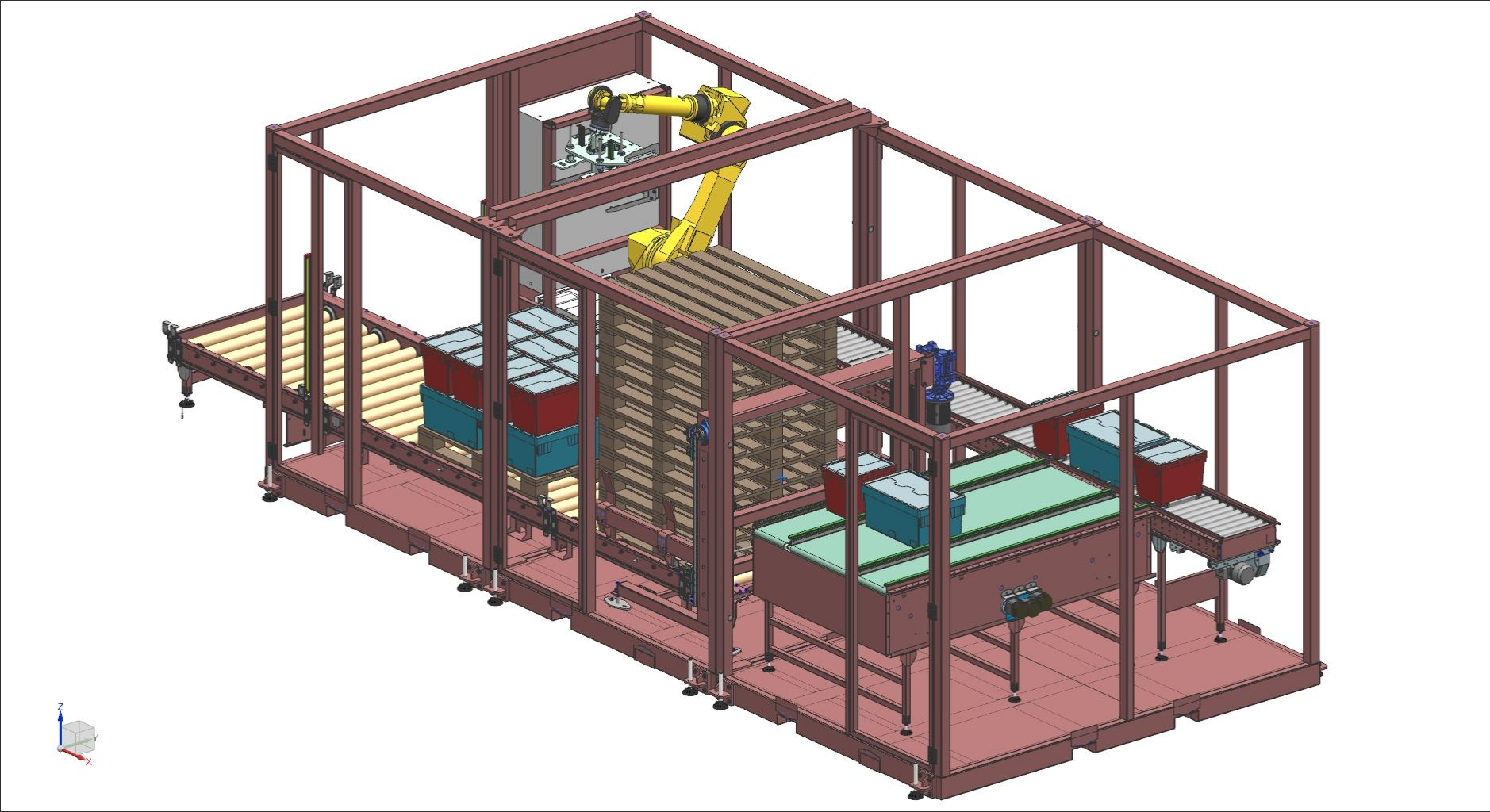

OPTION 5



Multiple lines
palletiser

Product infeed
conveyors with
collation

FANUC M410 robot

Pallet infeed with
auto de-stacker

Integrated Stretch
Wrapping System

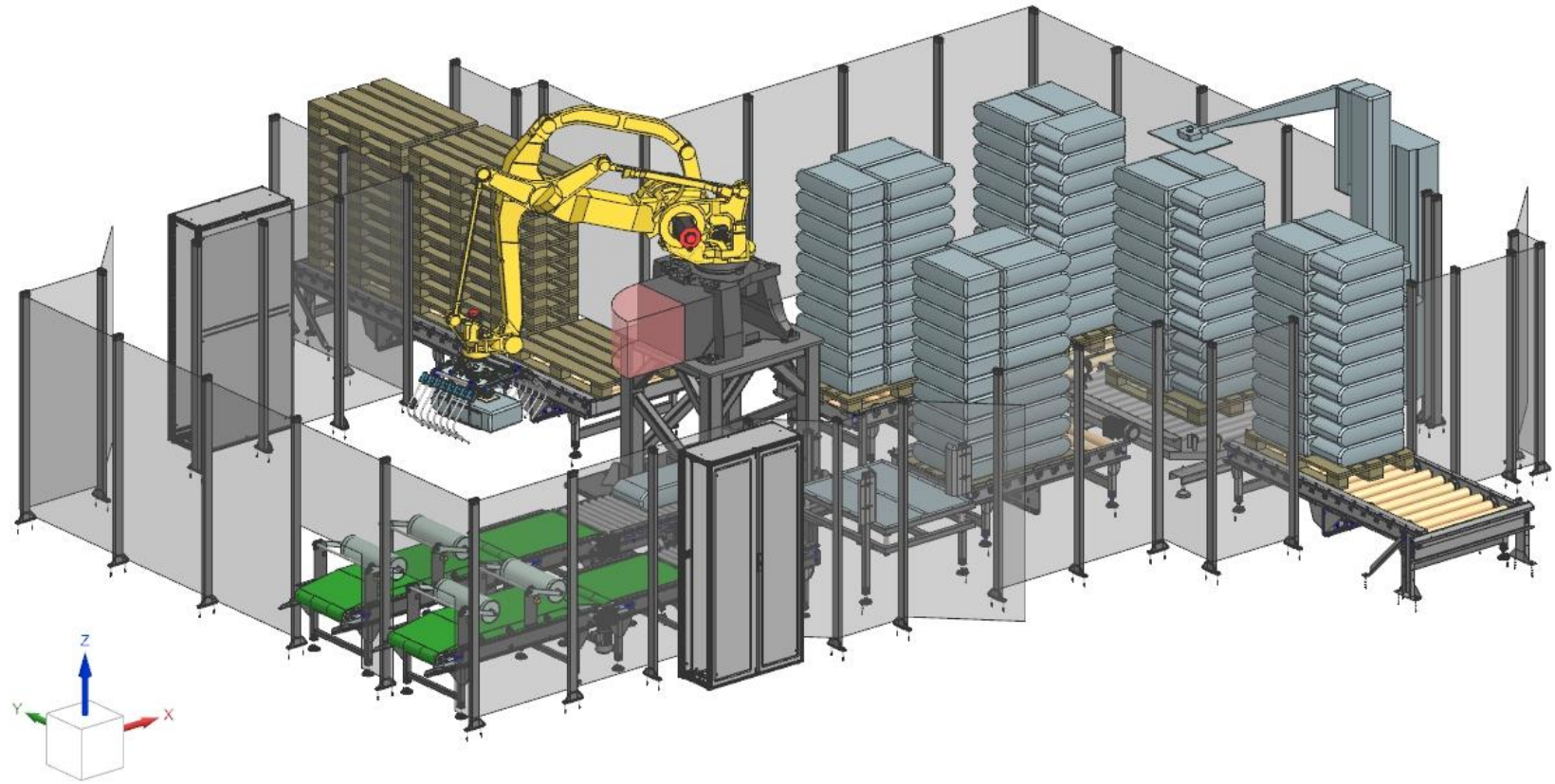

OPTION 5





www.endoline-robotics.com

+44 (0) 1767 310 581